



INSTALLATION INSTRUCTIONS FOR MOUNTING

LUVERNE GRILLE GUARD WITH THE FOLLOWING MODEL NO.:
331722/331723 & 341722/341723 ON:

2017 AND NEWER F-250 – F-550 SUPER DUTY SERIES TRUCKS

1. READ THE INSTRUCTIONS COMPLETELY AND CHECK TO MAKE SURE THAT ALL OF THE REQUIRED PARTS ARE ON HAND BEFORE STARTING THE INSTALLATION. THE CARTON SHOULD CONTAIN:
 - (1) OUTER RING PACKAGE
 - (1) OUTER RING ASSEMBLY
 - (1) UPRIGHT PACKAGE
 - (1) UPRIGHT ASSEMBLY, LH
 - (1) UPRIGHT ASSEMBLY, RH
 - (1) MOUNTING BRACKET, LH
 - (1) MOUNTING BRACKET, RH
 - (1) FRAME BRACE, LH
 - (1) FRAME BRACE, RH
 - (2) UPRIGHT COVERS (**CHROME GUARDS ONLY**)
 - (1) HARDWARE PACKAGE
 - (1) CUSTOMER SERVICE PACKAGE

REFER TO SHEETS #1, #2, #3, #4 & #5 FOR GUARD ASSEMBLY & INSTALLATION INSTRUCTIONS 2-13

2. ON THE LEFT SIDE OF THE VEHICLE, LOOSEN AND REMOVE THE TWO BOLTS IN THE FACE OF THE BUMPER, THAT SECURE THE BUMPER TO THE FRAME, ALSO REMOVE THE TWO BOLT RETAINER WASHERS BETWEEN THE BUMPER MOUNTING PLATE AND THE FRAME MOUNTING PLATE.
3. IF THE VEHICLE HAS AN ANTI-CLIMB OVER BRACKET REMOVE THE OUTSIDE BOLT SET THAT ATTACHES IT TO THE FRAME.
4. INSTALL THE LEFT HAND T-BOLT ASSEMBLY (ITEM #8) THROUGH THE HOLES IN THE FRAME FROM THE INSIDE. INSTALL TWO M12 X 1.75 FLANGE NUTS (ITEM #19) ON THE BOLTS AND TIGHTEN THE NUTS.
5. INSTALL TWO M12 X 1.75 FLANGE NUTS (ITEM #19) ON THE BOLTS WITH THE FLANGE FACING TO THE OUTSIDE AND TIGHTEN THE NUTS. (**NOTE: IF THE VEHICLE DOES NOT HAVE ANTI-CLIMB OVER BRACKETS YOU MAY HAVE TO ADJUST THIS NUT OUT TO GET THE HOLES IN THE BRACKET TO MATCH THE HOLES IN THE BUMPER.**) MOUNT THE LEFT HAND FRAME MOUNTING BRACKET BRACE (ITEM #6) ONTO THE BOLTS AND CHECK TO MAKE SURE THAT THE HOLES IN THE BRACE MATCH UP TO THE HOLES IN THE BUMPER. CHECK TO MAKE SURE THE HOLES WILL ALLOW THE ½" CARRIAGE BOLTS TO COME THROUGH THE FACE OF THE BUMPER.. INSTALL TWO M12 NUTS (ITEM #19) TO RETAIN THE BRACKET. LEAVE LOOSE AT THIS TIME.



6. ON THE LEFT HAND MOUNTING BRACKET (ITEM #4), INSTALL THE TWO 1/2"-13 X 2" CARRIAGE BOLTS (ITEM #13) IN THE HOLES OF THE MOUNTING BRACKETS, PLACE THE 5/8" FLAT WASHERS (ITEM #23) ON THE BOLTS AND INSTALL THE TWO PUSH NUTS (ITEM #20) ON THE BOLTS.
7. INSERT THE ASSEMBLED BRACKET INTO THE HOLES IN THE BUMPER AND FASTEN WITH 1/2" FLAT WASHERS (ITEM #24), 1/2" LOCK WASHERS (ITEM #21) AND 1/2" HEX NUTS (ITEM #18) AS SHOWN IN FIG. 1 & 2. HAND TIGHTEN ONLY AT THIS TIME.
8. REPEAT STEPS 2 THRU 9 FOR THE OPPOSITE SIDE.
9. INSTALL THE UPRIGHTS (ITEM #2 & #3) ONTO THE MOUNTING BRACKETS (ITEM #4 & #5) AND FASTEN WITH THE 1/2"-13 X 3" CARRIAGE BOLTS (ITEM #14), 1/2" SAE FLAT WASHERS (ITEM #25) AND 1/2"-13 ACORN NUTS (ITEM #17) .
10. INSTALL THE RING (ITEM #1) BY LOWERING IT DOWN FROM THE TOP AND BEHIND THE UPRIGHTS, (TAKING CARE NOT TO SCRAPE THE ENDS OF THE RING AGAINST THE SIDE OF THE VEHICLE.) AND SLIDE THE RING INTO THE NOTCHES OF THE UPRIGHTS. FASTEN WITH THE UPRIGHT COVERS (ITEM #22) (**CHROME GUARDS ONLY**), 7/16"-14 X 1-1/2" HEX BOLTS (ITEM #15) AND 7/16" FLAT WASHERS (ITEM #26) INTO THE 7/16"-14 CAPTIVE NUTS (ITEM #27) IN THE UPRIGHT MOUNTING PLATES.
11. CHECK THAT THE GRILL GUARD IS CENTERED AND VERTICAL ON THE BUMPER AND THE UPRIGHTS ARE STRAIGHT UP AND DOWN. THEN TIGHTEN THE FOUR 7/16" BOLTS (ITEM #15) SECURING THE RING TO THE UPRIGHTS.
12. TIGHTEN THE FOUR 1/2" NUTS (ITEM #18) SECURING THE UPRIGHTS TO THE BUMPER MOUNTING BRACKET AND THE MOUNTING BRACES.
13. TIGHTEN THE 1/2"-13 NUTS (ITEM #19) THAT SECURE THE MOUNTING BRACKET BRACE (ITEM #6 & #7) TO THE FRAME.



SERVICE PARTS LIST

ITEM	PART NO.	QTY	DESCRIPTION
1	202980	1	RING WELDMENT – CHROME
1	202986	1	RING WELDMENT – BLACK
2	202960	1	UPRIGHT WELDMENT – CHROME, LH
2	202984	1	UPRIGHT WELDMENT – BLACK, LH
3	202961	1	UPRIGHT WELDMENT – CHROME, RH
3	202985	1	UPRIGHT WELDMENT – BLACK, RH
4	202967	1	MOUNTING BRACKET - LH
5	202968	1	MOUNTING BRACKET - RH
6	202971	1	MOUNTING BRACE – LH
7	202972	1	MOUNTING BRACE – RH
8	202973	1	T-BOLT ASSEMBLY - LH, BZP
9	202974	1	T-BOLT ASSEMBLY - RH, BZP
10	202518	2	TAPPING BAR – 16.000”
11	202038	2	TAPPING BAR – 11.500”
12	202517	2	RUBBER EXTRUSION – MACHINED, 32.687”
13	107422	4	CARRIAGE BOLT – 1/2”-13 X 2, ZP
14	107231	4	CARRIAGE BOLT – 1/2”-13 X 3, SST
15	105939	4	HEX HEAD SCREW – 7/16”-14 X 1-1/2”, SST
16	103715	10	SELF TAPPING SCREW – 1/4”-20 X 5/8”, ZP
17	104994	4	ACORN NUT - 1/2”-13, SST
18	100124	4	HEX NUT – 1/2”-13, ZP
19	100794	12	HEX FLANGE NUT – M12 X 1.75, ZP
20	108733	4	PUSHNUT – 1/2”, ZP
21	100121	4	LOCK WASHER – 1/2”, ZP
22	202759	2	UPRIGHT COVER (CHROME GUARDS ONLY)
23	100147	4	FLAT WASHER – 5/8”, ZP
24	100118	4	FLAT WASHER – 1/2”, ZP
25	104995	4	FLAT WASHER – SAE, 1/2”, SST
26	103286	4	FLAT WASHER – 7/16”, SST
27	100083	4	CAPTIVE NUT – 7/16”-14
28	105293	4	TUBE PLUG – Ø1-1/4”
29	106902	1	MATTE BLACK DECAL – LH
30	106901	1	MATTE BLACK DECAL – RH
31	100252	1	DECAL – LOGO, 1 X 3



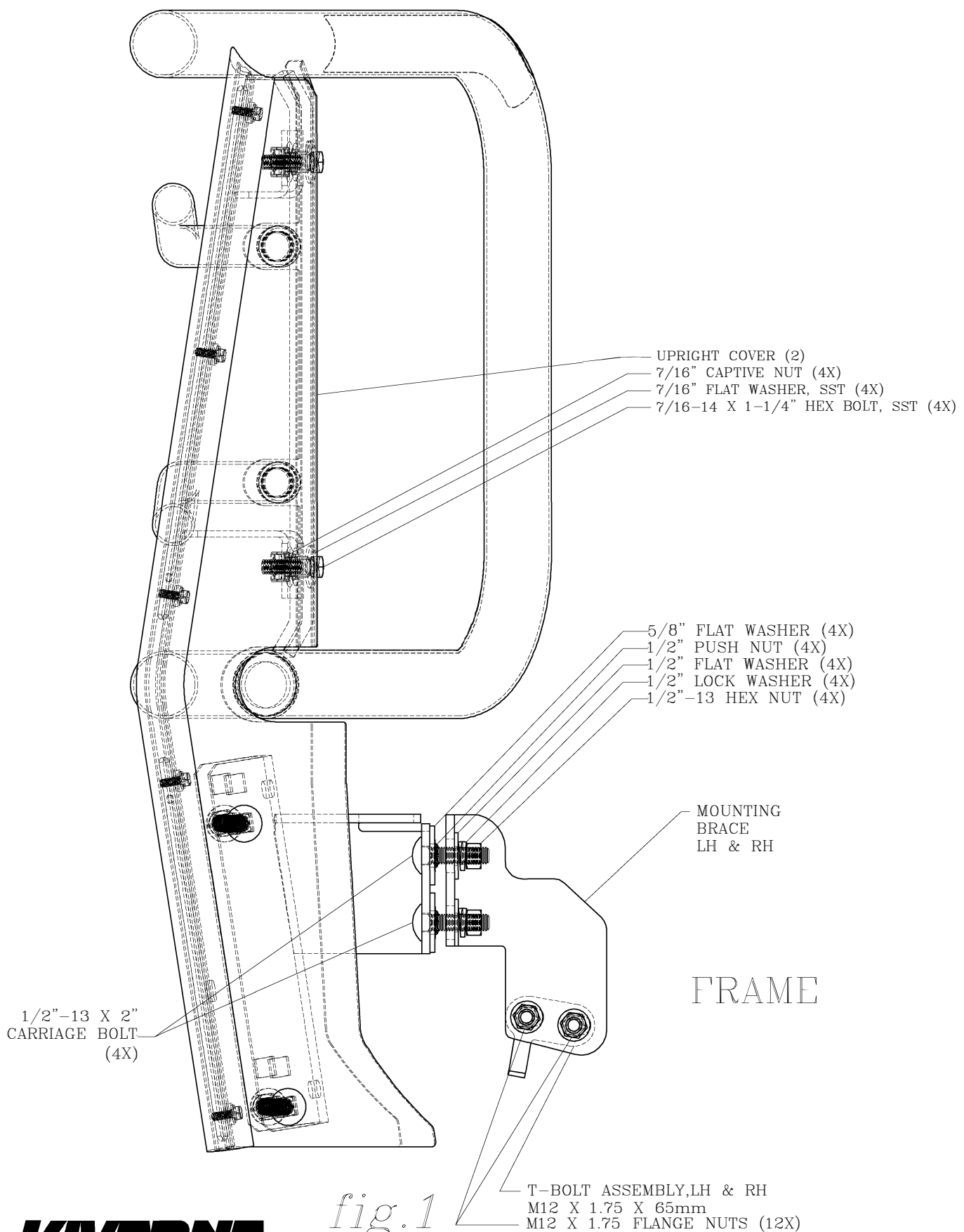

fig.1



SERVICE PARTS LIST

MODEL NO. - 331722/331723

MODEL NO. - 341520/341523

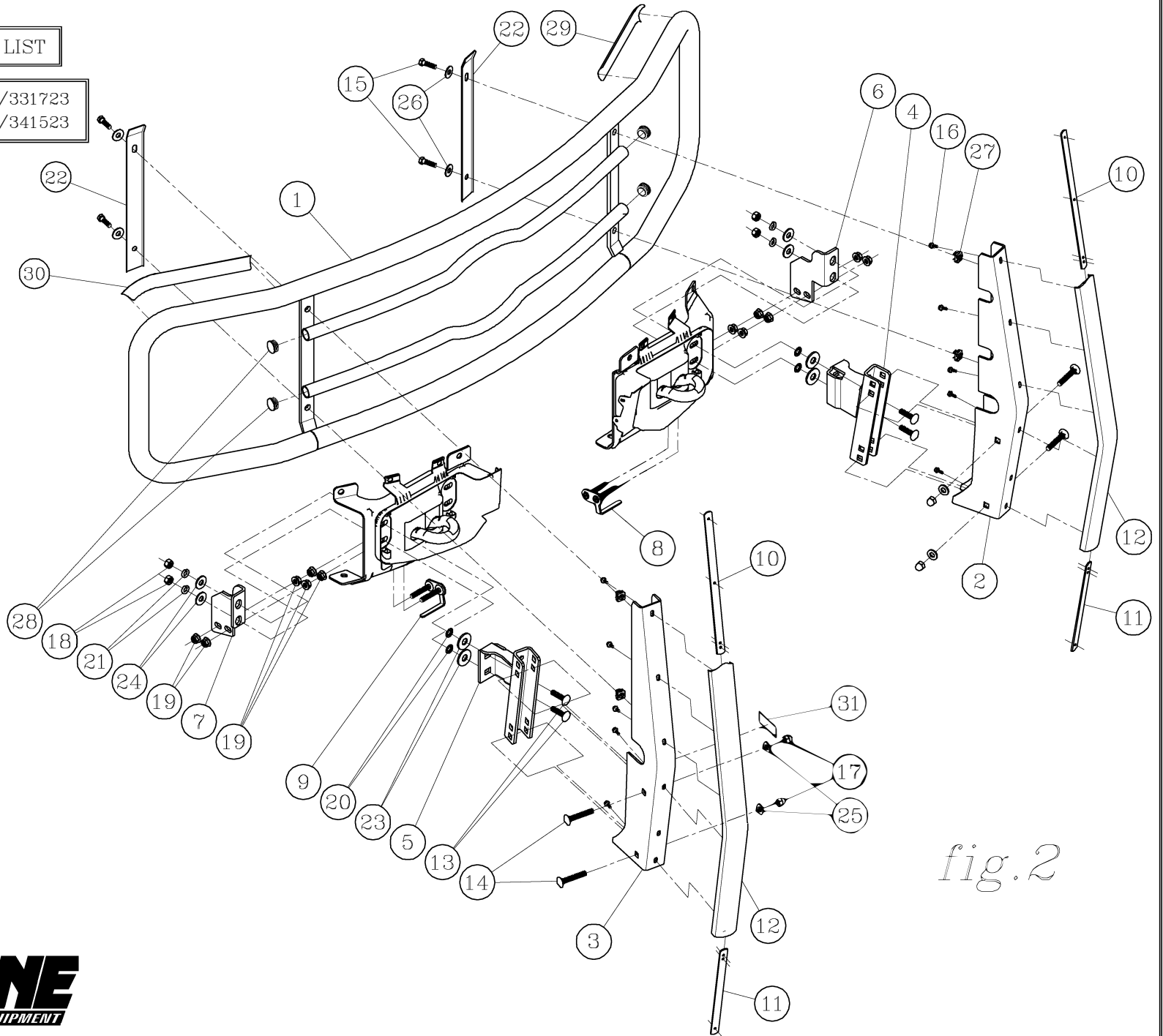

fig. 2

