



INSTALLATION INSTRUCTIONS FOR MOUNTING

LUVERNE GRILL GUARDS WITH THE FOLLOWING MODEL NOS.:
331514 OR 331544/331519 & 341514 OR 341544/341519 ON:

2015 AND NEWER CHEVROLET TAHOE & SUBURBAN
2015 AND NEWER GMC YUKON & YUKON XL

1. READ THE INSTRUCTIONS COMPLETELY AND CHECK TO MAKE SURE THAT ALL OF THE REQUIRED PARTS ARE ON HAND BEFORE STARTING THE INSTALLATION. THE CARTON SHOULD CONTAIN:
 - (1) OUTER RING PACKAGE
 - (1) OUTER RING ASSEMBLY
 - (1) UPRIGHT/BRACKET PACKAGE:
 - (2) ASSEMBLED UPRIGHTS
 - (1) MOUNTING BRACKET, RH
 - (1) MOUNTING BRACKET, LH
 - (2) UPRIGHT COVERS (**CHROME GUARDS ONLY**)
 - (1) FASTENER PACKAGE
 - (1) CUSTOMER SERVICE PACKAGE

REFER TO FIGS. 1 & 2 FOR GUARD ASSEMBLY INSTRUCTIONS 2-11

2. IF YOUR VEHICLE HAS TOW HOOKS, LOOSEN AND REMOVE THE TWO BOLTS AND NUT THAT HOLD THEM IN THE END OF THE FRAME. REMOVE THE TOW HOOKS. THE HOLE IN THE CLOSEOUT PANEL WILL NEED TO BE ENLARGED UPWARD APPROXIMATELY 1/2" TO ALLOW THE BRACKETS TO INSTALL IN THE FRAME.
3. IF YOUR VEHICLE DOES NOT HAVE TOW HOOKS IT WILL BE NECESSARY TO CUT HOLES IN THE CLOSEOUT PANELS. MARK OUT A 3" X 3-1/4" SQUARE USING THE DIMENSIONS ON PAGE #5 OF THESE INSTRUCTIONS. DRILL 1/2" DIAMETER HOLES IN THE CORNER OF THE SQUARES, THEN CUT THE STRAIGHT LINES FROM THE TANGENT OF EACH HOLE. (**NOTE: SEE PAGE 6 FOR CUTTING TEMPLATES.**)
4. INSTALL THE LEFT HAND MOUNTING BRACKET (ITEM #4) INTO THE END OF THE FRAME. FASTEN WITH THE 1/2"-13 X 1-1/2" BOLT (ITEM #11), 1/2"-13 X 4-1/2" HEX BOLT (ITEM #10), 1/2" LOCK WASHER (ITEM #17) AND THE 1/2"-13 SERRATED FLANGE NUT (ITEM #14). LEAVE LOOSE AT THIS TIME. (**NOTE: AFTER INSERTING THE BRACKETS THROUGH THE HOLE, INSTALL THE HOLE TRIM (ITEM #24) AROUND THE EDGE OF THE HOLES IN THE CLOSEOUT PANEL.**)
5. REPEAT STEP #5 ON THE RIGHT SIDE.
6. INSTALL ONE OF THE UPRIGHTS (ITEM #2) ON THE LEFT HAND MOUNTING BRACKET (ITEM #4) AND FASTEN WITH THE 1/2"-13 X 3 CARRIAGE BOLTS (ITEM #9), 1/2" SAE FLAT WASHERS (ITEM #19), AND THE 1/2"-13 CAP NUTS (ITEM #15). LEAVE LOOSE AT THIS TIME.
7. REPEAT STEP #6 ON THE RIGHT SIDE.

8. LOWER THE CENTER RING ASSEMBLY (ITEM #1) DOWN BEHIND THE UPRIGHTS AND INSTALL IN THE SLOTS OF THE UPRIGHTS AS SHOWN IN FIG. 1 & 2. MAKING SURE THE UPRIGHTS ARE CENTERED AND PARALLEL WITH THE BARS IN THE RING, FASTEN WITH UPRIGHT COVERS (ITEM #18) (**CHROME GUARDS ONLY**), 7/16"-14 X 1-1/2" HEX BOLTS (ITEM #12), AND 7/16" FLAT WASHERS (ITEM #20) INTO THE 7/16"-14 CAPTIVE NUTS (ITEM #16) IN THE UPRIGHT MOUNTING PLATES. TIGHTEN TO 40 FOOT-POUNDS OF TORQUE.
9. CHECK THAT THE GRILL GUARD IS CENTERED ON THE GRILLE AND THE REAR OF THE UPRIGHT CUTOUT IS APPROXIMATELY 1/2"-3/4" AWAY FROM THE FACE OF THE BUMPER.
10. TIGHTEN THE 1/2" NUTS ON THE CARRIAGE BOLTS FASTENING THE MOUNTING BRACKETS TO UPRIGHTS TO 75 FOOT-POUNDS OF TORQUE.
11. TIGHTEN THE 1/2" BOLTS THAT FASTEN THE BOTTOM MOUNTING BRACKETS TO THE FRAME TO 75 FOOT-POUNDS OF TORQUE.

SERVICE PARTS LIST

ITEM	PART NO.	QTY	DESCRIPTION
1	202770	1	RING WELDMENT – CHROME
1	202773	1	RING WELDMENT – BLACK
2	202761	2	UPRIGHT WELDMENT – CHROME,
3	202772	2	UPRIGHT WELDMENT – BLACK
4	202764	1	MOUNTING BRACKET – LH, 331514
4	202854	1	MOUNTING BRACKET – LH, 331544
5	202765	1	MOUNTING BRACKET – RH, 331514
5	202855	1	MOUNTING BRACKET – RH, 341544
6	201122	2	TAPPING BAR – 13.000"
7	201243	2	TAPPING BAR – 14.000"
8	202383	2	RUBBER EXTRUSION – MACHINED, 330712
9	107231	4	ROUND HEAD BOLT – 1/2"-13 X 3", SST
10	100107	2	HEX HEAD SCREW – 1/2"-13 X 4-1/2", ZP
11	100088	2	HEX HEAD SCREW - 1/2"-13 x 1-1/2", ZP
12	105939	4	HEX HEAD SCREW - 7/16"-14 x 1-1/4", SST
13	103715	12	SELF TAPPING SCREW – 1/4"-20 X 5/8"
14	100123	2	SERRATED FLANGE NUT – 1/2"-13
15	104994	4	HEX CAP NUT – 1/2"-13, SST
16	100083	4	NUT CAPTIVE – 7/16", BLK
17	100121	2	LOCK WASHER – 1/2", ZP
18	202544	2	UPRIGHT COVERS (CHROME GUARDS ONLY)
19	104995	4	FLAT WASHER – SAE, 1/2", SST
20	103286	4	FLAT WASHER – 7/16", SST
21	106901	1	DECAL – MATTE BLACK, RH, 330460
22	106902	1	DECAL – MATTE BLACK, LH, 330460
23	100252	1	DECAL – LOGO, 1 X 3
24	201215	2	UPRIGHT TRIM – 14.500"

**FOR INSTALLATION ON:
CHEVROLET SUBURBAN & TAHOE**

2. 3" X 3-1/4" HOLES WILL NEED TO BE CUT OUT IN THE CLOSE OUT PANEL IN THE FACE OF THE FRONT BUMPER.

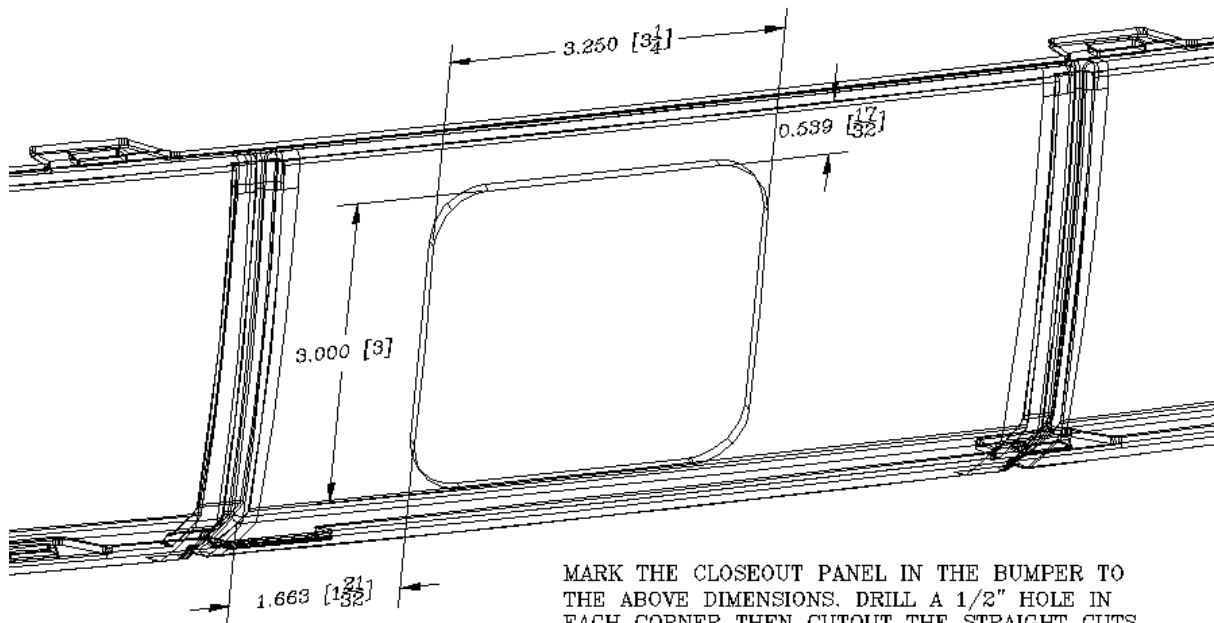
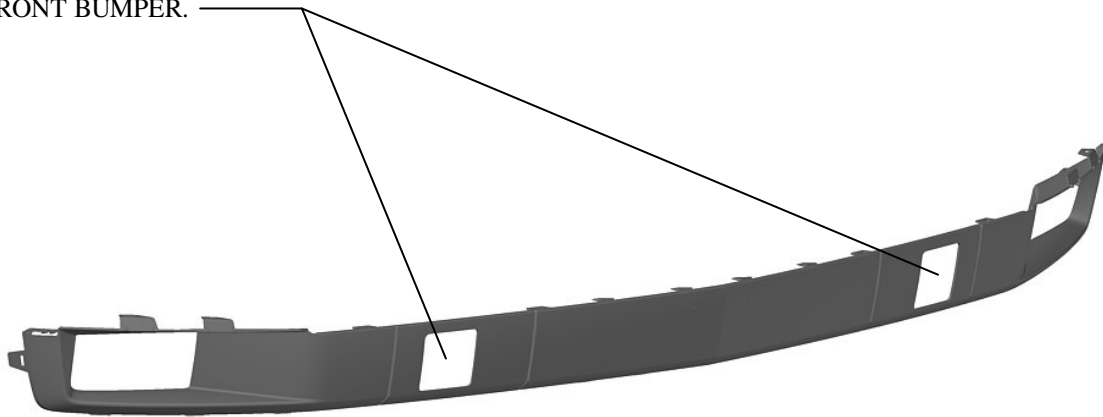

MARK THE CLOSEOUT PANEL IN THE BUMPER TO THE ABOVE DIMENSIONS. DRILL A 1/2" HOLE IN EACH CORNER THEN CUTOUT THE STRAIGHT CUTS BETWEEN THE TANGENT POINTS. THE HOLES SHOULD BE 32" ON CENTER MEASURED ALONG THE FACE OF THE CLOSEOUT PANEL.

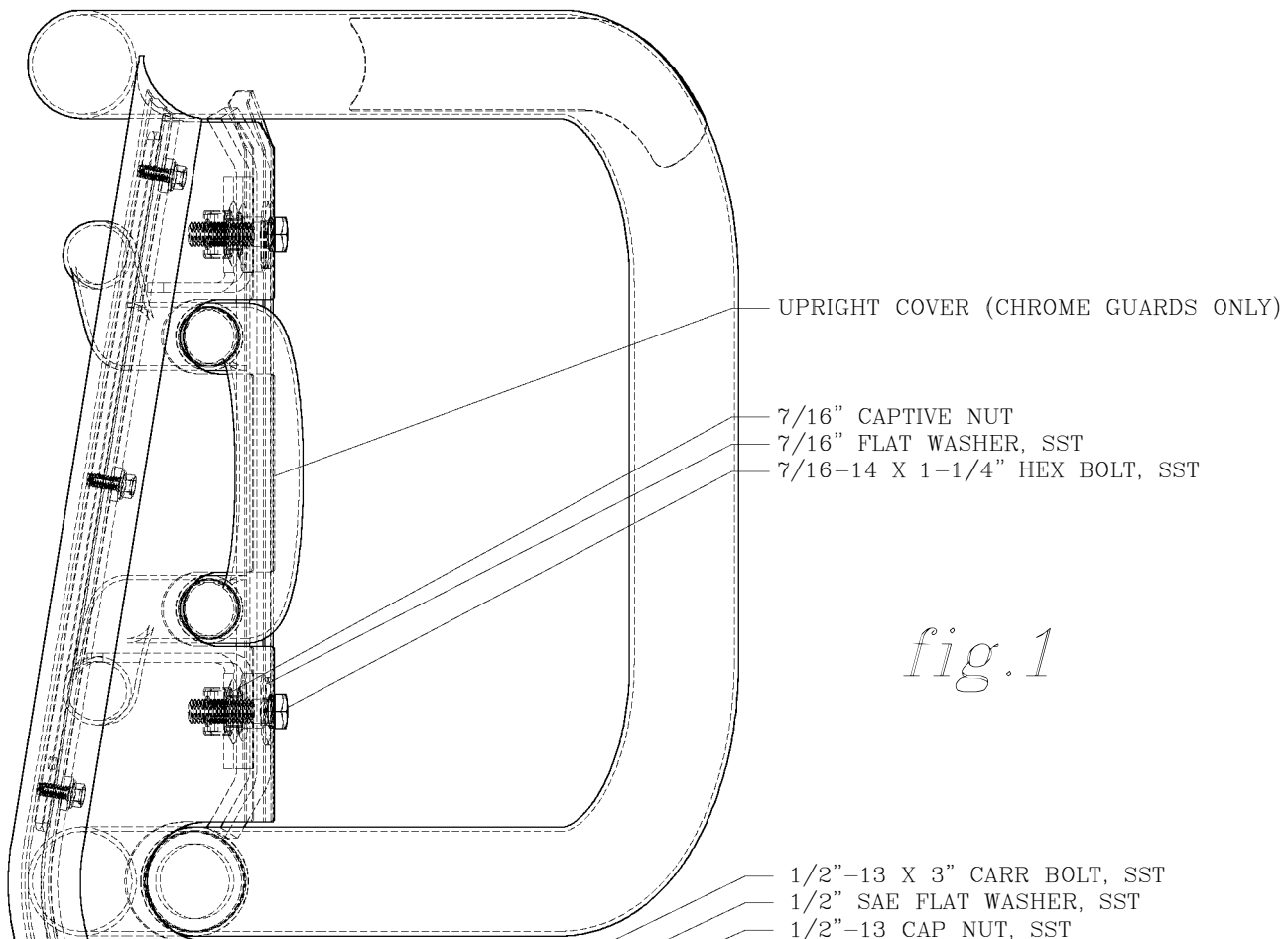
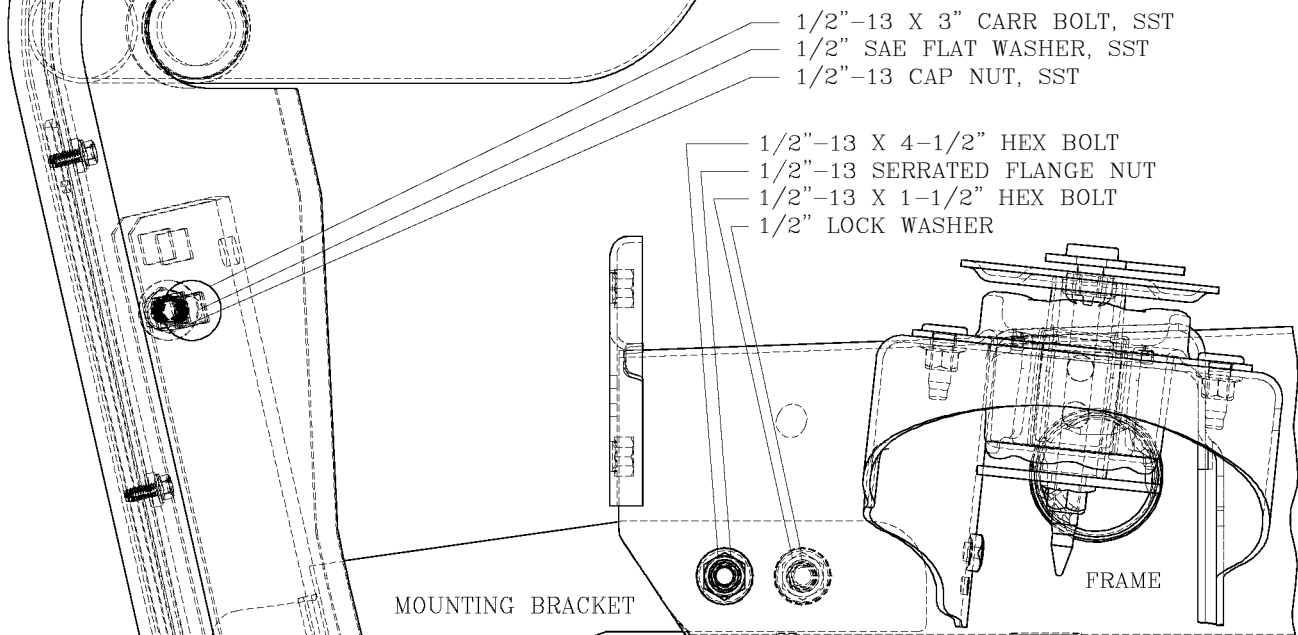

fig.1



THESE HOLES FOR GMC

THESE HOLES FOR CHEVROLET

- 1/2"-13 X 3" CARR BOLT, SST
- 1/2" SAE FLAT WASHER, SST
- 1/2"-13 CAP NUT, SST



SERVICE PARTS LIST

MODEL NO. - 331514/331519
331544/331519
MODEL NO. - 341514/341519
341544/341519

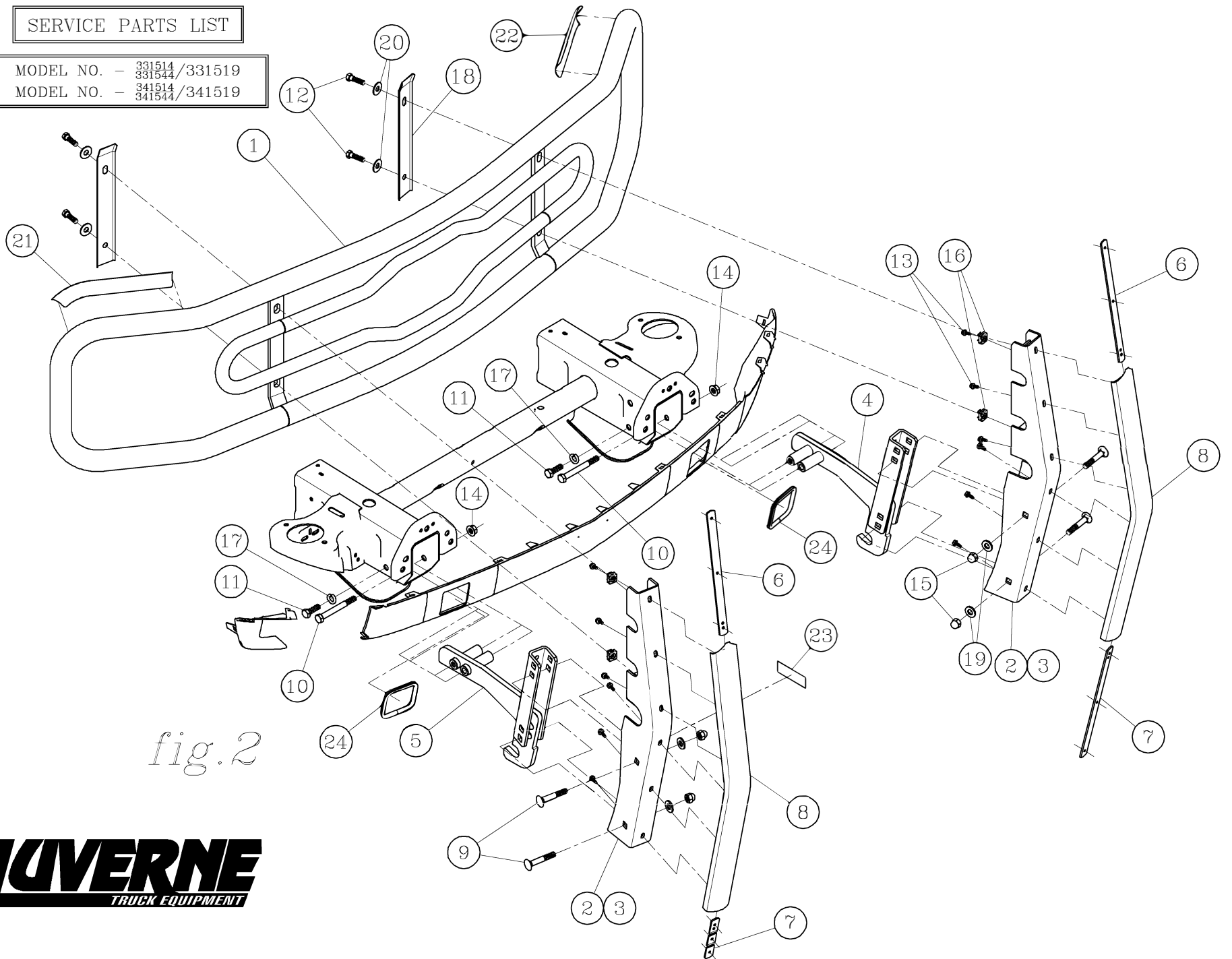
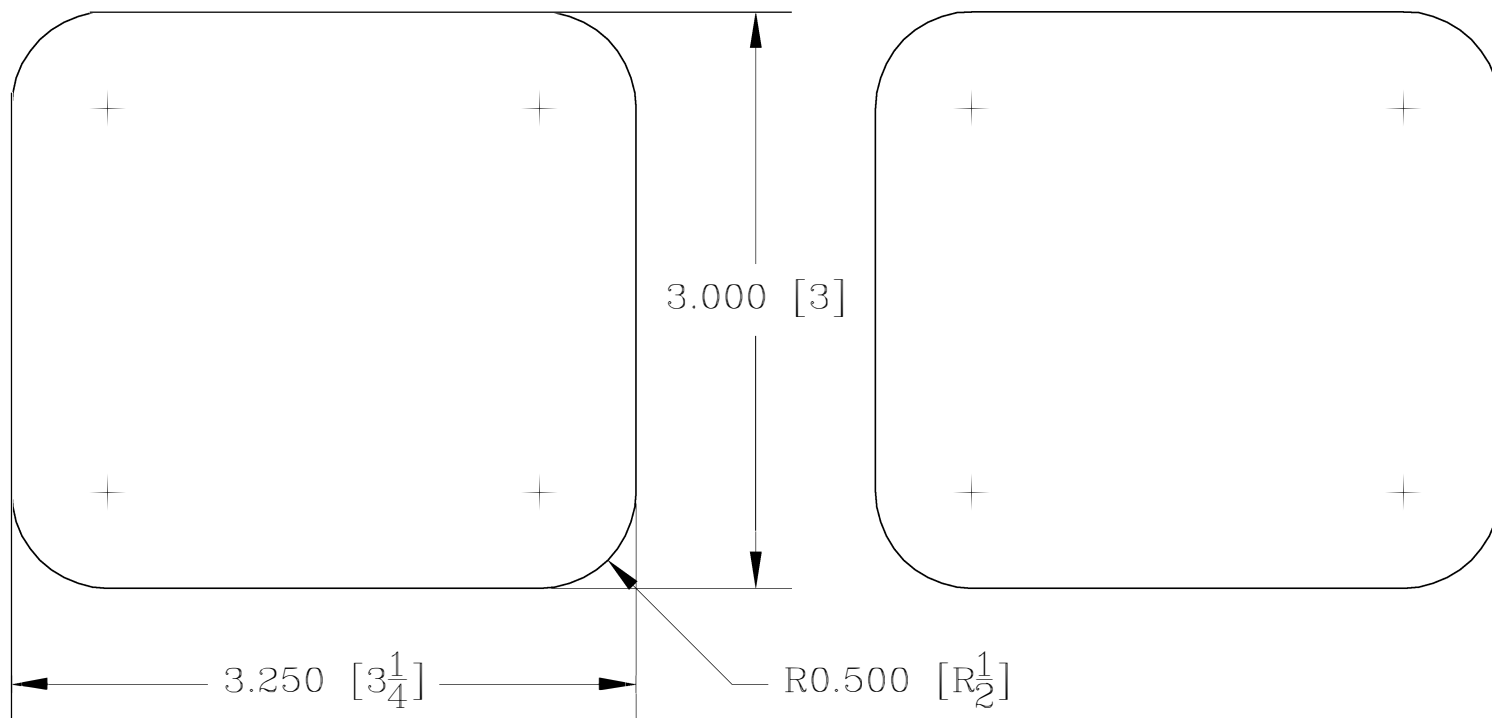

fig. 2



1. CUT OUT THE TEMPLATES ABOVE AND TAPE THEM TO THE CLOSEOUT PANEL ACCORDING TO THE DIMENSIONS ON PAGE 5.
2. USING THE CENTER MARKS ON THE TEMPLATES, DRILL A HOLE WITH A Ø1" HOLE SAW.
3. USING A HACK SAW BLADE OR UTILITY KNIFE CUT THE LINES FROM THE TANGENT POINTS OF THE RADII TO REMOVE THE MATERIAL IN THE HOLE.
4. AFTER THE HOLES ARE CUT, USE THE RUBBER CHANNEL MATERIAL IN THE CUSTOMER SERVICE PACKAGE TO TRIM THE EDGES OF THE HOLES.