



INSTALLATION INSTRUCTIONS FOR MOUNTING

LUVERNE GRILL GUARDS WITH THE FOLLOWING MODEL NOS.:
330714/330719 & 340714/340719 ON:

2007 AND NEWER CHEVROLET TAHOE, SUBURBAN & AVALANCHE
2007 AND NEWER GMC YUKON & YUKON XL

1. READ THE INSTRUCTIONS COMPLETELY AND CHECK TO MAKE SURE THAT ALL OF THE REQUIRED PARTS ARE ON HAND BEFORE STARTING THE INSTALLATION. THE CARTON SHOULD CONTAIN:
 - (1) OUTER RING PACKAGE
 - (1) OUTER RING ASSEMBLY
 - (1) UPRIGHT/BRACKET PACKAGE:
 - (1) ASSEMBLED UPRIGHT, RH
 - (1) ASSEMBLED UPRIGHT, LH
 - (1) MOUNTING BRACKET, RH
 - (1) MOUNTING BRACKET, LH
 - (2) UPRIGHT COVERS (**CHROME GUARDS ONLY**)
 - (1) FASTENER PACKAGE
 - (1) CUSTOMER SERVICE PACKAGE

REFER TO FIGS. 1 & 2 FOR GUARD ASSEMBLY INSTRUCTIONS 2-11

2. DISCONNECT THE PLASTIC SHROUDS AROUND THE TOW HOOKS FROM THE FRONT FASCIA.
NOTE: SEE SHEET #5 FOR INSTRUCTIONS ABOUT THE GMC TOW HOOK PANEL.
3. LOOSEN AND REMOVE THE TWO BOLTS AND NUT THAT HOLD THE TOW HOOKS TO THE END OF THE FRAME. REMOVE THE TOW HOOKS AND THE PLASTIC SHROUDS.
4. INSTALL THE RIGHT HAND MOUNTING BRACKET (ITEM #4) INTO THE END OF THE FRAME. FASTEN WITH THE ½-13 X 1-1/2 BOLT (ITEM #11), ½-13 X 4-1/2 HEX BOLT (ITEM #10), 1/2" LOCK WASHER (ITEM #17) AND THE ½-13 SERRATED FLANGE NUT (ITEM #14). LEAVE LOOSE AT THIS TIME.
5. REPEAT STEP #5 ON THE LEFT SIDE.
6. **CHEVROLET:** INSTALL THE RIGHT HAND UPRIGHT (ITEM #2) ON THE RIGHT HAND MOUNTING BRACKET (ITEM #4) AND FASTEN WITH THE ½-13 X 3 CARRIAGE BOLTS (ITEM #9), 1/2" SAE FLAT WASHERS (ITEM #19), AND THE ½-13 CAP NUTS (ITEM #15). LEAVE LOOSE AT THIS TIME.
GMC: INSTALL ONLY THE LOWER BOLT AND ALLOW THE UPRIGHT TO TILT OUT. YOU WILL NEED THE CLEARANCE TO GET THE RING INSTALLED.
7. REPEAT STEP #7 ON THE LEFT SIDE.

8. **CHEVROLET:** LOWER THE CENTER RING ASSEMBLY (ITEM #1) DOWN BEHIND THE UPRIGHTS AND INSTALL IN THE SLOTS OF THE UPRIGHTS AS SHOWN IN FIG. 1 & 2. **GMC:** IT WILL BE NECESSARY TO START TILTING THE UPRIGHTS TOWARD THE VEHICLE IN ORDER TO GET THE BOLTS INTO THE NUTS IN THE UPRIGHTS. MAKING SURE THE UPRIGHTS ARE CENTERED AND PARALLEL WITH THE BARS IN THE RING, FASTEN WITH UPRIGHT COVERS (ITEM #18) (**CHROME GUARDS ONLY**), 7/16-14 X 1-1/2 HEX BOLTS (ITEM #12), AND 7/16 FLAT WASHERS (ITEM #20) INTO THE 7/16-14 CAPTIVE NUTS (ITEM #16) IN THE UPRIGHT MOUNTING PLATES. TIGHTEN TO 54 FOOT-POUNDS OF TORQUE.
9. CHECK THAT THE GRILL GUARD IS CENTERED ON THE GRILLE AND THE REAR OF THE UPRIGHT CUTOUT IS APPROXIMATELY ½-¾" AWAY FROM THE FACE OF THE BUMPER.
10. TIGHTEN THE ½" NUTS ON THE CARRIAGE BOLTS FASTENING THE MOUNTING BRACKETS TO UPRIGHTS TO 75 FOOT-POUNDS OF TORQUE.
11. TIGHTEN THE ½" BOLTS THAT FASTEN THE BOTTOM MOUNTING BRACKETS TO THE FRAME TO 75 FOOT-POUNDS OF TORQUE.

SERVICE PARTS LIST

ITEM	PART NO.	QTY	DESCRIPTION
1	202250	1	RING WELDMENT – CHROME
1	202268	1	RING WELDMENT – BLACK
2	202254	1	UPRIGHT WELDMENT – CHROME, RH
2	202269	1	UPRIGHT WELDMENT – BLACK, RH
3	202255	1	UPRIGHT WELDMENT – CHROME, LH
3	202270	1	UPRIGHT WELDMENT – BLACK, LH
4	202261	1	MOUNTING BRACKET – RH
5	202262	1	MOUNTING BRACKET – LH
6	202038	2	TAPPING BAR – 11.500"
7	201122	2	TAPPING BAR – 13.000"
8	202264	2	RUBBER EXTRUSION – MACHINED, 330714
9	107231	4	ROUND HEAD BOLT – ½-13 X 3, SST
10	100107	2	HEX HEAD SCREW – ½-13 X 4-1/2, ZP
11	100088	2	HEX HEAD SCREW-1/2-13 x 1-1/2, ZP
12	105939	4	HEX HEAD SCREW-7/16-14 x 1-1/4, SST
13	103715	10	SELF TAPPING SCREW – ¼-20 X 5/8
14	100123	2	SERRATED FLANGE NUT – ½-13
15	104994	4	HEX CAP NUT – 1/2-13, SST
16	100083	4	NUT CAPTIVE – 7/16, BLK
17	100121	2	LOCK WASHER – 1/2, ZP
18	202543	2	UPRIGHT COVERS (CHROME GUARDS ONLY)
19	104995	4	FLAT WASHER – SAE, ½, SST
20	103286	4	FLAT WASHER – 7/16, SST
21	105293	4	TUBE PLUG – Ø1-1/4 X 14-20 GA.
22	106901	1	DECAL – MATTE BLACK, RH, 330460
23	106902	1	DECAL – MATTE BLACK, LH, 330460
24	100252	1	DECAL – LOGO, 1 X 3

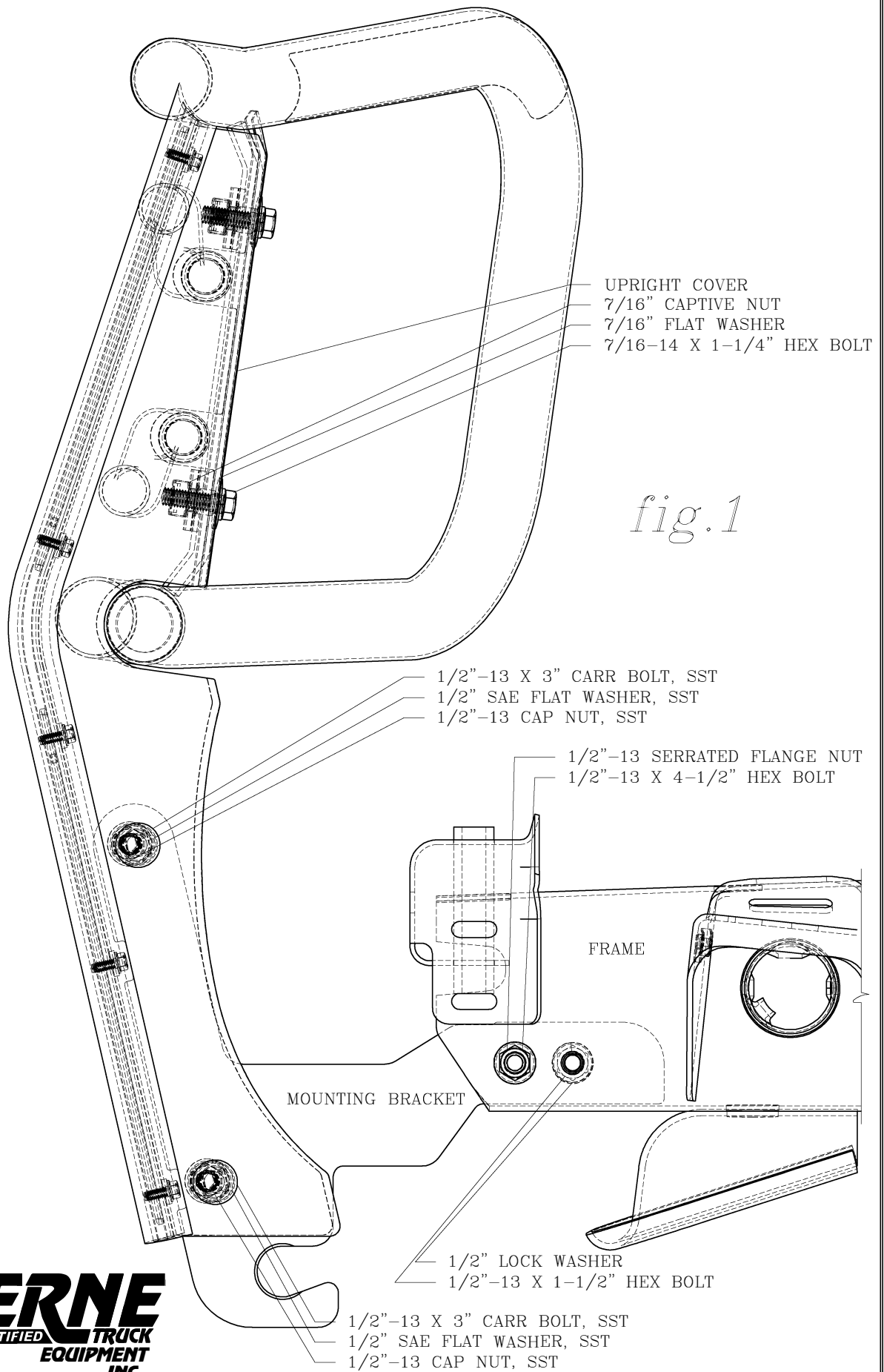

SERVICE PARTS LIST

MODEL NO. - 330714/330719
MODEL NO. - 340714/340719

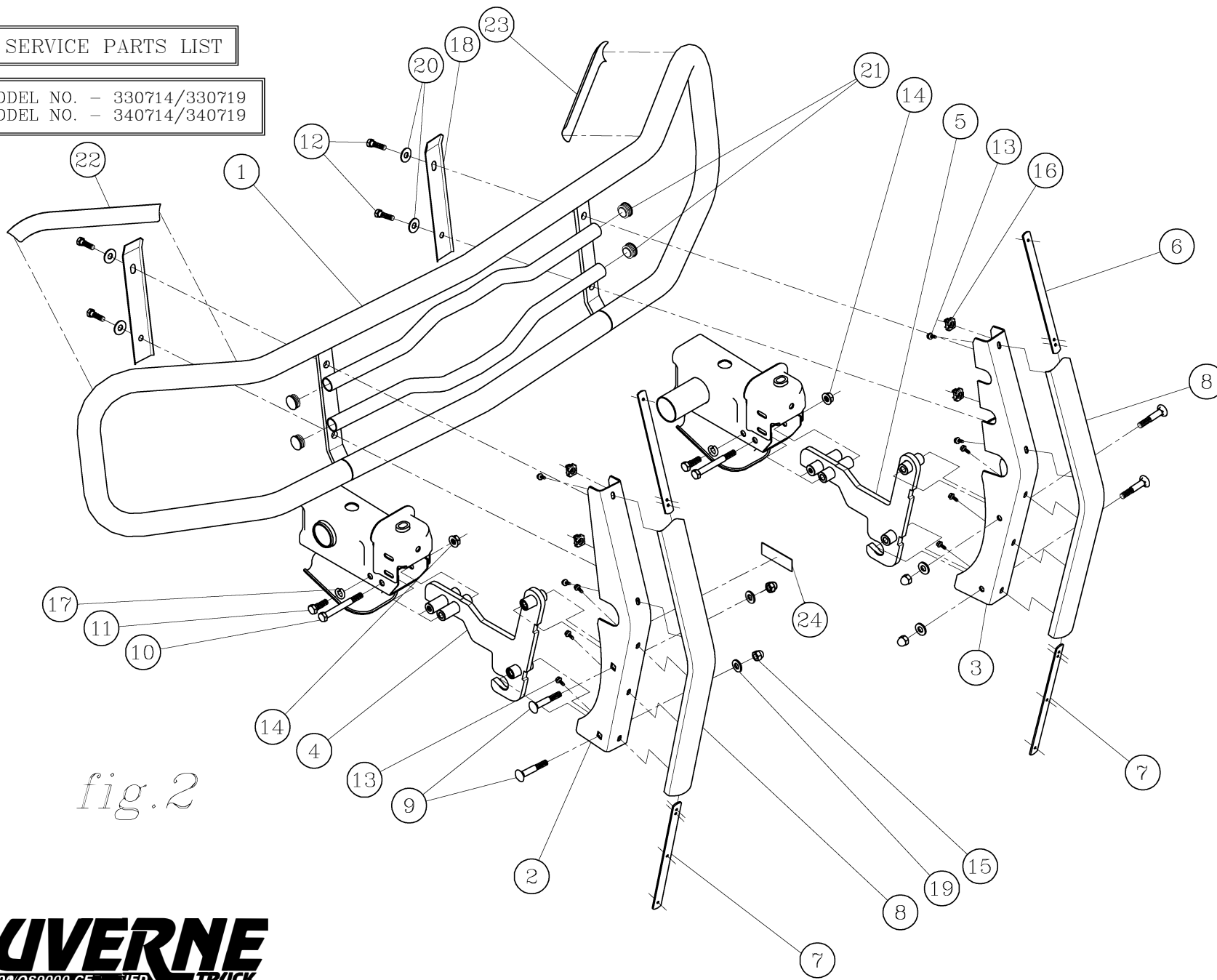

fig.2

FOR INSTALLATION ON GMC YUKON AND YUKON XL

2. REMOVE THE PLASTIC PANEL THAT COVERS THE TOW HOOKS AND THE AREA BEHIND THE LICENSE PLATE. TO REMOVE THE PANEL:
 1. REMOVE THE TWO CHRISTMAS TREE FASTENERS IN EACH TOW HOOK CAVITY. ONE ON THE TOP SIDE AND ONE ON THE BOTTOM SIDE.
 2. FROM THE BACK SIDE, UNSNAP THE TEN RETAINERS IN THE CENTER THAT HOLD THE TOW HOOK PANEL TO FRONT FASCIA.
 3. PULL THE TWO ENDS OF THE PANEL OUTSIDE OF THE TOW HOOKS STRAIGHT OUT TO UNSNAP THE TWO RETAINERS ON EACH END.



1. CHRISTMAS TREES



2. 10 RETAINERS



3. PULL END STRAIGHT OUT

1. IN ORDER TO REUSE THE TOW HOOK PANEL IN CONJUNCTION WITH THE MOUNTING BRACKETS IT WILL BE NECESSARY TO TRIM THE TOW HOOK PANEL IN ONE OF THE FOLLOWING WAYS:

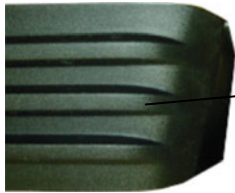

USING A SHARP UTILITY KNIFE, TRIM OFF THE ENTIRE END OF THE TOW HOOK PANEL. SEE STEP #2 FOR REMOVAL OF THE TOW HOOK PANEL. THIS WILL ALLOW EASIER CUTTING OF THE PANEL.

OR

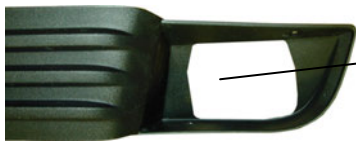

TRIM A RECTANGULAR HOLE USING THE OUTSIDE EDGES OF THE EXISTING HOLE ON THE SIDES AND CUTTING TO THE CORNER JOINT IN THE TOP AND BOTTOM. (**NOTE:** AFTER TRIMMING THE PLASTIC IT WILL BE NECESSARY TO REINSTALL THE PANEL BEFORE INSTALLING THE BRACKETS.)

OR

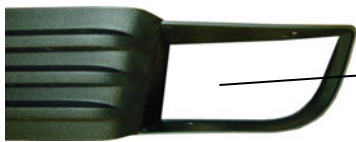

REMOVE THE COMPLETE INDENTED PORTION OF THE PLASTIC BY CUTTING THROUGH THE PART AT THE SHARP CORNER WHERE THE SIDE FLANGES MEET THE BOTTOM. (**NOTE:** AFTER TRIMMING THE PLASTIC IT WILL BE NECESSARY TO REINSTALL THE PANEL BEFORE INSTALLING THE BRACKETS.)

LIVERNE
ISO 9001 CERTIFIED TRUCK
EQUIPMENT
INC.