



INSTALLATION INSTRUCTIONS FOR MOUNTING

LUVERNE GRILL GUARDS WITH THE FOLLOWING MODEL NOS.:
351413/321411, 310713/321411 & 320713/321411 ON:

2014 AND NEWER 1500 CHEVROLET SILVERADO PICKUPS
2014 AND NEWER 1500 GMC SIERRA PICKUPS

1. READ THE INSTRUCTIONS COMPLETELY AND CHECK TO MAKE SURE THAT ALL OF THE REQUIRED PARTS ARE ON HAND BEFORE STARTING THE INSTALLATION. THE CARTON SHOULD CONTAIN:
 - (1) GRILLE GUARD PACKAGE – #310713 or #320713 or #351413
 - (1) GRILLE GUARD ASSEMBLY
 - (1) BRACKET PACKAGE: #321411
 - (1) MOUNTING BRACKET, LH
 - (1) MOUNTING BRACKET, RH
 - (1) FASTENER PACKAGE
 - (1) CUSTOMER SERVICE PACKAGE

REFER TO FIG. 1 FOR GUARD ASSEMBLY INSTRUCTIONS 2-8

2. LOOSEN AND REMOVE THE REAR BOLTS AND NUT FROM THE LONG BOLTS AT THE FRONT OF THE FRAME THAT HOLD THE TOW HOOKS TO THE END OF THE FRAME. AFTER THE NUTS ON THE LONG BOLTS AT THE FRONT ARE REMOVED IT WILL BE NECESSARY TO CUT OFF THE HEADS FROM THE BOLTS, AT LEAST ON THE DRIVERS SIDE OF THE CHEVROLET. BOTH HEADS WILL HAVE TO BE CUT OFF ON THE GMC IN ORDER TO GET THE BOLTS OUT OF THE FRAME. REMOVE THE TOW HOOKS AND THE FOAM COVERS ATTACHED TO THEM.
3. INSTALL THE LEFT HAND MOUNTING BRACKET (ITEM #2) ON TO THE END OF THE FRAME. **(NOTE: BEFORE INSTALLING THE BRACKETS ON A GMC SIERRA, TRIM OUT THE INNER ENDS OF THE TOW HOOK SHROUDS WITH A UTILITY KNIFE TO ALLOW THE INSERTION OF THE BRACKETS.)** FASTEN WITH M12 X 1.75 X 30mm HEX BOLTS (ITEM #4) AND THE M12 X 1.75 SERRATED FLANGE NUTS (ITEM #6). LEAVE LOOSE AT THIS TIME.
4. REPEAT STEP #3 ON THE RIGHT SIDE.
5. INSTALL THE GRILLE GUARD WELDMENT ONTO THE MOUNTING BRACKETS (ITEM #2 & #3) WITH THE BRACKET TO THE INSIDE OF THE UPRIGHTS. **(NOTE: USE THE BOTTOM HOLES IN THE MOUNTING BRACKETS FOR CHEVROLET SILVERADO AND THE TOP HOLES FOR THE GMC SIERRA.)** FASTEN WITH THE 1/2"-13 X 1-1/2" CARRIAGE BOLTS (ITEM #5), 1/2" SAE WASHERS (ITEM #8), 1/2" LOCK WASHERS (ITEM #9), AND THE 1/2"-13 CAP NUTS (ITEM #7). LEAVE LOOSE AT THIS TIME.
6. TIGHTEN THE BOLTS ATTACHING THE BRACKETS TO THE FRAME TO 54 FOOT POUNDS.
7. CHECK THAT THE GRILL GUARD IS CENTERED ON THE GRILLE AND THE REAR OF THE UPRIGHT CUTOUT IS APPROXIMATELY 1/2"-3/4" AWAY FROM THE FACE OF THE BUMPER.
8. TIGHTEN THE 1/2"-13 CAP NUTS (ITEM #7) ON THE 1/2"-13 X 1-1/2" CARRIAGE BOLTS (ITEM #5), FASTENING THE MOUNTING BRACKETS TO THE GRILLE GUARD TO 70 FOOT POUNDS.

LUVERNE
TRUCK EQUIPMENT

SERVICE PARTS LIST

ITEM	PART NO.	QTY	DESCRIPTION
1	320713	1	GRILLE GUARD WELDMENT - BLACK
1	310713	1	GRILLE GUARD WELDMENT - SST
1	202942	1	BAJA GUARD WELDMENT, BLACK
2	202873	1	MOUNTING BRACKET – LH
3	202874	1	MOUNTING BRACKET – RH
4	103439	6	HEX HEAD SCREW- M12 X 1.75 X 30mm, ZP
5	104131	4	ROUND HEAD BOLT – 1/2”-13 X 1-1/2”, BLK ZP
6	100794	6	SERRATED FLAGE NUT – M12 X 1.75, BLK ZP
7	109510	4	CAP NUT – 1/2”-13, BLACK ZP
8	100940	4	FLAT WASHER – 1/2”, SAE, BLACK ZP
9	109511	4	LOCK WASHER – 1/2”, BLACK ZP
10	106888	1	DECAL – LOGO, LUVERNE, 3/4” X 3”
11	109992	2	BUMPER STRIP, RUBBER, BAJA GUARD



SERVICE PARTS LIST

MODEL NO. - 310713/321411

MODEL NO. - 320713/321411

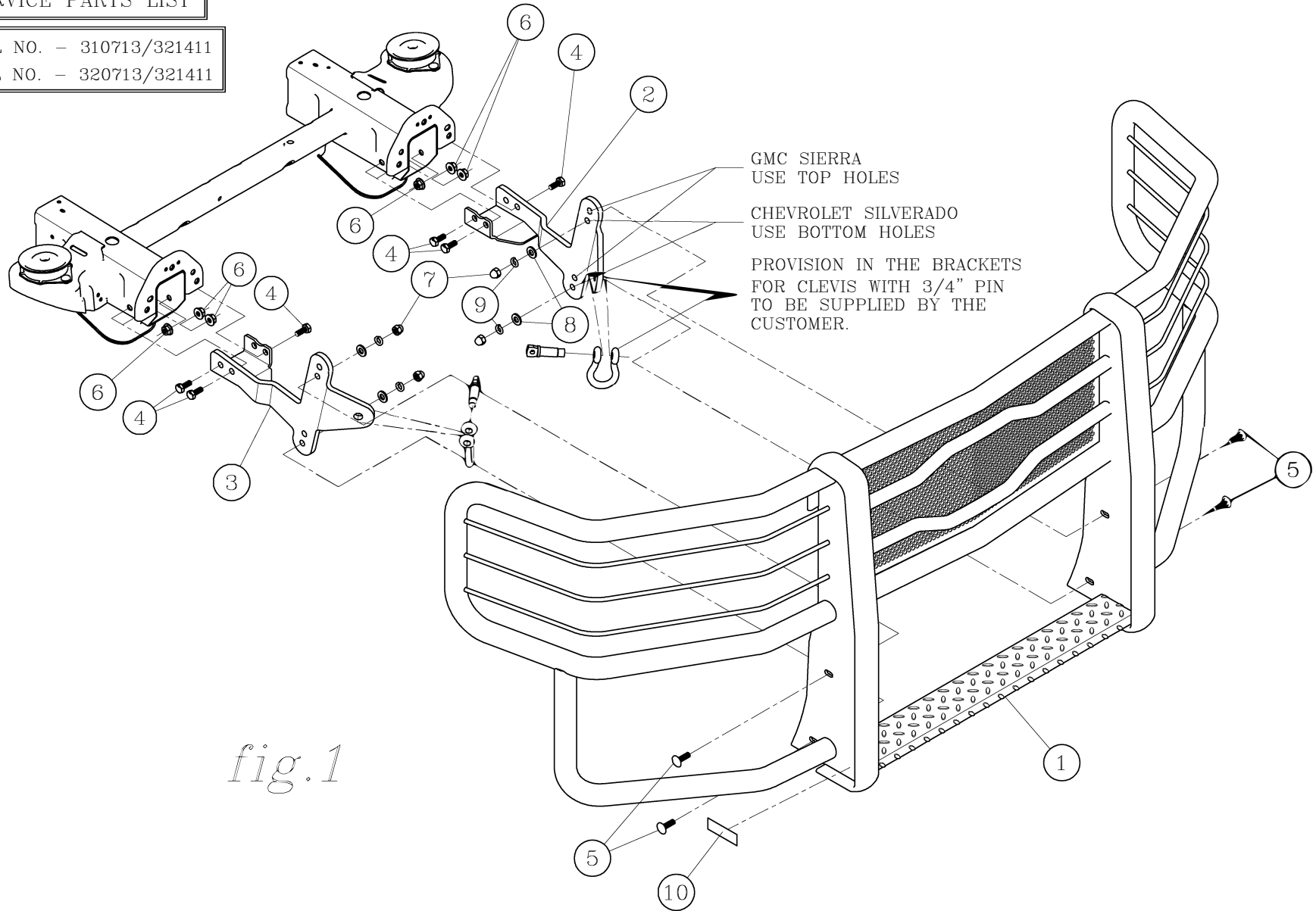

fig.1

SERVICE PARTS LIST

MODEL NO. - 351413/321411

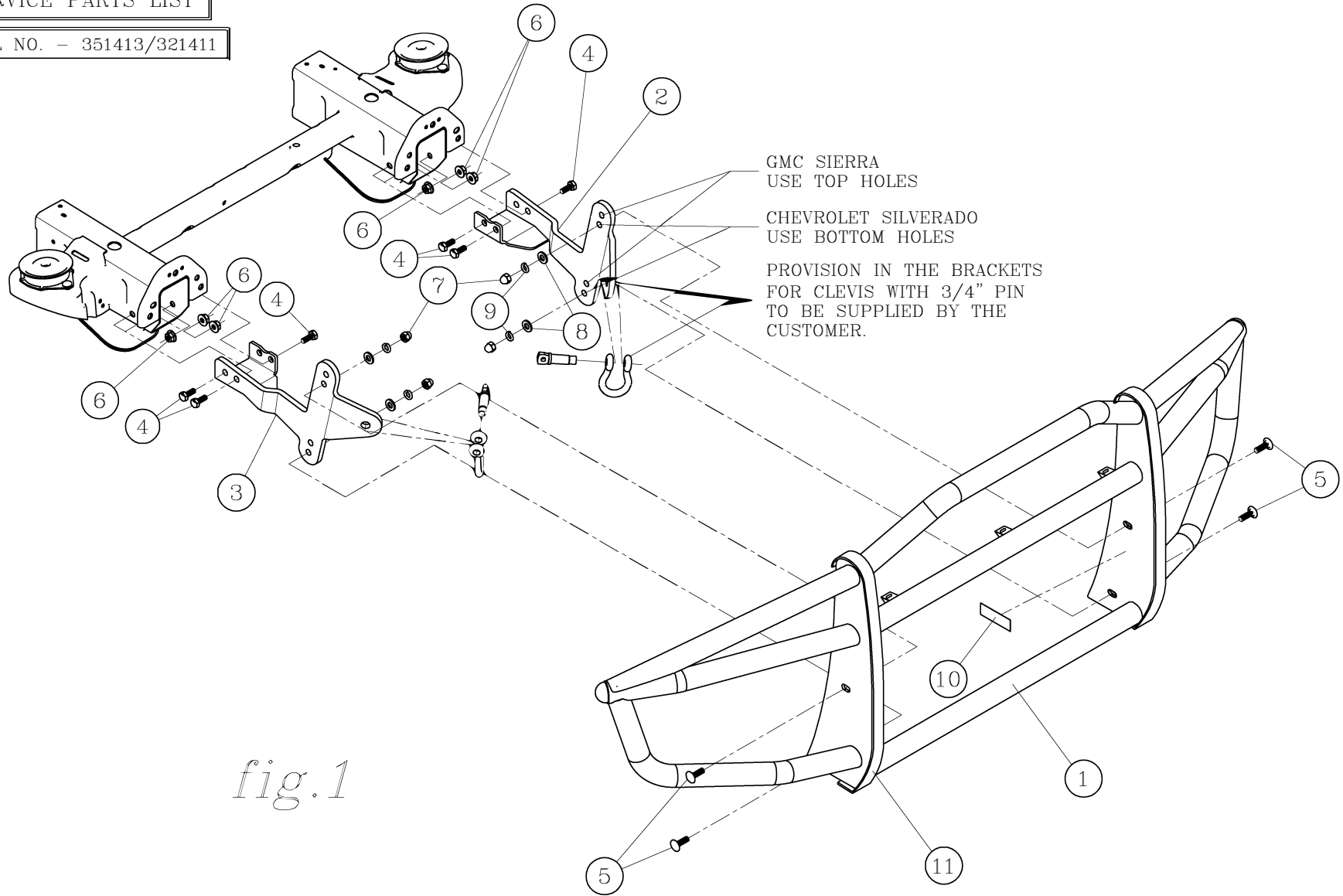

fig.1

