

## INSTALLATION INSTRUCTIONS AND PARTS LIST

### APPLICATION: MODEL 289922/289923 (STAINLESS STEEL) SIDE ENTRY STEP BOARDS: ROCKER PANEL MOUNT APPLICATION

1. READ INSTRUCTIONS COMPLETELY AND CHECK TO MAKE SURE THAT ALL REQUIRED PARTS (LISTED ON SERVICE PARTS LIST) ARE ON HAND BEFORE STARTING THE INSTALLATION.
2. **NOTE: REFER TO FIG 1. FOR THE SUPER CAB, AND FIG 2. FOR THE SUPER CREW AND CHECK THAT THE STEP BOARD BRACKETS ARE MOUNTED IN THE CORRECT LOCATIONS.** WITH THE STEP BOARD BRACKETS ATTACHED TO THE VEHICLE ON THE LEFT SIDE OF THE VEHICLE PLACE THE STEP BOARD (ITEM #1) ON THE BRACKETS AND CHECK THAT THE MOUNTING HOLES LINE UP. (THE LUVERNE STICKER SHOULD BE ON THE FRONT DRIVERS SIDE)
3. USING SIX (6) 10-24 X .75" CARRIAGE BOLTS (ITEM #3), AND SIX (6) 10-24 FLANGE NUTS (ITEM #4) ATTACH THE STEP BOARD TO THE BRACKETS. NOTE: TWO CARRIAGE BOLTS SHOULD ALREADY BE INSTALLED UNDERNEATH THE STEP PAD.
4. ADJUST STEP IN/OUT TO ALIGN STEP WITH THE CAB.
5. TIGHTEN THE STEP MOUNTING BOLTS.
6. REPEAT FOR RIGHT SIDE OF VEHICLE.

### SERVICE PARTS LIST

ITEM	PART NO.	QTY	DESCRIPTION
1	553020	1	STEP PLATE-SES, BLACK, LH, SUPER CAB, 289922
1	553022	1	STEP PLATE-SES, BLACK, LH, SUPER CREW, 289923
2	553021	1	STEP PLATE-SES, BLACK, RH, SUPER CAB, 289922
2	553023	1	STEP PLATE-SES, BLACK, RH, SUPER CREW, 289923
3	109685	12	BOLT – CARRIAGE – SST, BLK, 10-24 X .75"
4	104261	40	NUT – FLANGE, SST, 10-24
5	104250	2	END CAP – RH FRONT/LH REAR
6	104251	2	END CAP – LH FRONT/RH REAR
7	104255	2	TRIM – SEAL, EXTRUSION, 80.50"
8	105500	4	STEP PAD, 5.50 X 20.00
9	104257	8	NUT – HEX, SINGLE THREAD
10	107958	4	SCR-PPH, #8-18 X .5", SST
11	107645	4	CLIP-U, .118-.185, BLK
12	107863	24	BOLT – CARRIAGE, 10-24 X .5", BZP
13	104258	2	BOLT – CARRIAGE, 10-24 X .75", SST
14	104259	2	BOLT – CARRIAGE, CLIPPED HEAD, 10-24 X .75", SST



# INSTALLATION INSTRUCTIONS AND PARTS LIST

## MODEL 579922 MEGA STEPS BRACKETS:

1999 AND NEWER FORD SUPER DUTY SUPER CAB AND CREW CAB PICKUPS



1. READ INSTRUCTIONS COMPLETELY AND CHECK TO MAKE SURE THAT ALL REQUIRED PARTS (LISTED ON SERVICE PARTS LIST) ARE ON HAND BEFORE STARTING THE INSTALLATION.
2. EXISTING MOUNTING HOLE PATTERNS ARE LOCATED ON THE PINCH WELD AND INTERIOR WALL OF THE ROCKER PANEL. THESE MOUNTING HOLE PATTERNS MUST BE USED FOR THIS INSTALLATION PER THE FOLLOWING INSTRUCTIONS.
  - 2.1. STARTING AT THE FRONT, INSTALL 5/16" MULTI THREAD U-NUTS (ITEM #6) IN THE TOP REAR HOLE OF THE FIRST, SECOND AND THIRD PATTERNS AND IN THE FRONT TOP HOLE OF THE FIFTH OR REAR PATTERN AS SHOWN. INSTALL THESE U-NUTS SO THAT THE THREADS ARE TO THE INSIDE OF THE ROCKER PANEL. (THIS IS DONE BY INSERTING THE THREADED HALF OF THE U-NUT THRU THE LARGE ACCESS HOLES AND SLIDING THE U-NUT TOWARDS THE ROUND HOLE UNTIL IT SEATS IN THE ROUND HOLE).
3. ATTACH THE MOUNTING BRACKETS (ITEM #2 & #3) TO THE VEHICLE. (NOTE: THE FRONT MOUNTING BRACKET, ITEM #2, HAS A 3/16" OFFSET AT THE TOP OF THE BRACKET).
  - 3.1. POSITION THE BRACKETS ON THE VEHICLE SO THAT THE TOP HOLE LINES UP WITH THE MULTI THREAD U-NUT AND THE BOTTOM HOLE LINES UP WITH THE HOLE IN THE PINCH WELD. ATTACH THE TOP OF THE BRACKET WITH A 5/16" X 1.00" ZINC PLATED HEX HEAD CAP SCREW (ITEM #7) AND 5/16" ZINC PLATED FLAT WASHER (ITEM #8). ATTACH THE BOTTOM OF THE BRACKET TO THE PINCH WELD WITH A 5/16" X 1.00" BLACK PLATED HEX HEAD CAP SCREW (ITEM #9), 5/16" BLACK PLATED FLAT WASHER (ITEM #10) AND 5/16" SERRATED FLANGE NUT (ITEM #5). LEVEL THE BRACKETS AND TIGHTEN THE FASTENERS TO 19 LB FT.
4. ATTACH THE STEP (ITEM #1) TO THE MOUNTING BRACKETS.
  - 4.1. INSERT FOUR (4) 5/16" SQUARE HEAD SCREWS (ITEM #4) IN THE CENTER SLOT ON THE UNDER SIDE OF THE STEP.
  - 4.2. POSITION THE STEP ON THE MOUNTING BRACKETS SO THAT THE SQUARE HEAD SCREWS ARE LOCATED IN THE SLOTS OF THE MOUNTING BRACKETS AND THE STEP IS CENTERED, FRONT TO REAR, ON THE CAB.
  - 4.3. LOCATE THE STEP, IN AND OUT, AS DESIRED, INSTALL 5/16" SERRATED FLANGE NUTS (ITEM #5) ON THE SQUARE HEAD SCREWS AND TIGHTEN TO 19 LB FT.
  - 4.4. INSTALL 5/16-18 SERRATED FLANGE NUTS (ITEM #5) ON ANY UNUSED SQUARE HEAD SCREWS IN THE INBOARD SLOT OF THE STEP AND TIGHTEN TO 19 LB FT.

## SERVICE PARTS LIST

ITEM	PART NO.	QTY	DESCRIPTION
1		2	MEGA STEP BOARD ASSEMBLY (SOLD SEPARATELY) LENGTH WILL VARY DEPENDING ON APPLICATION
2	551562	2	BRKT- MTG, STEP, SUPER DUTY PICKUP, FRONT
3	551563	6	BRKT- MTG, STEP, SUPER DUTY PICKUP
4	106880	8	SCREW-SQUARE HEAD, 5/16 18 UNC
5	102680	24	NUT-SERRATED FLANGE, HEX, SST, 5/16-18 UNC
6	104264	8	U-NUT- MULTI THREAD, 5/16-18 UNC, STL, BLK
7	100647	8	SCREW- HEX HEAD CAP, 5/16 18 UNC X 1.00".ZP
8	100034	8	WSHR-PL, A, STL, 5/16,.375 ID X .875 OD X .083 THK, ZP
9	106997	8	SCREW- HEX HEAD CAP, 5/16 18 UNC X 1.00", SST, BZP
10	106998	8	WSHR-PL, A, SST, 5/16,.375 ID X .875 OD X .083 THK, BZP



SERVICE PARTS LIST

MODEL NO. -289922

# SUPER CAB

fig.1

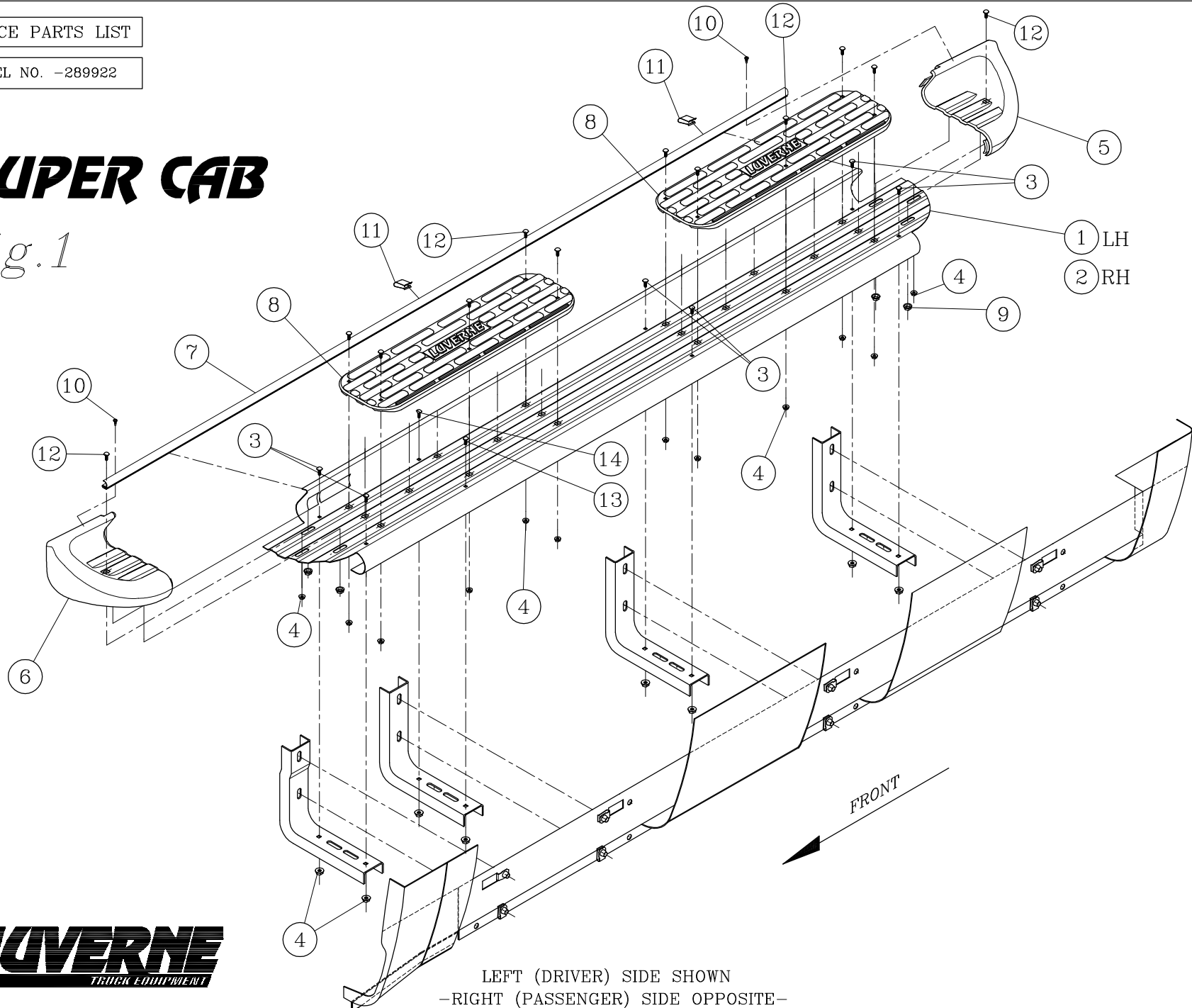

LEFT (DRIVER) SIDE SHOWN  
-RIGHT (PASSENGER) SIDE OPPOSITE-

SERVICE PARTS LIST

MODEL NO. -289923

# ***SUPER CREW***

*fig.2*

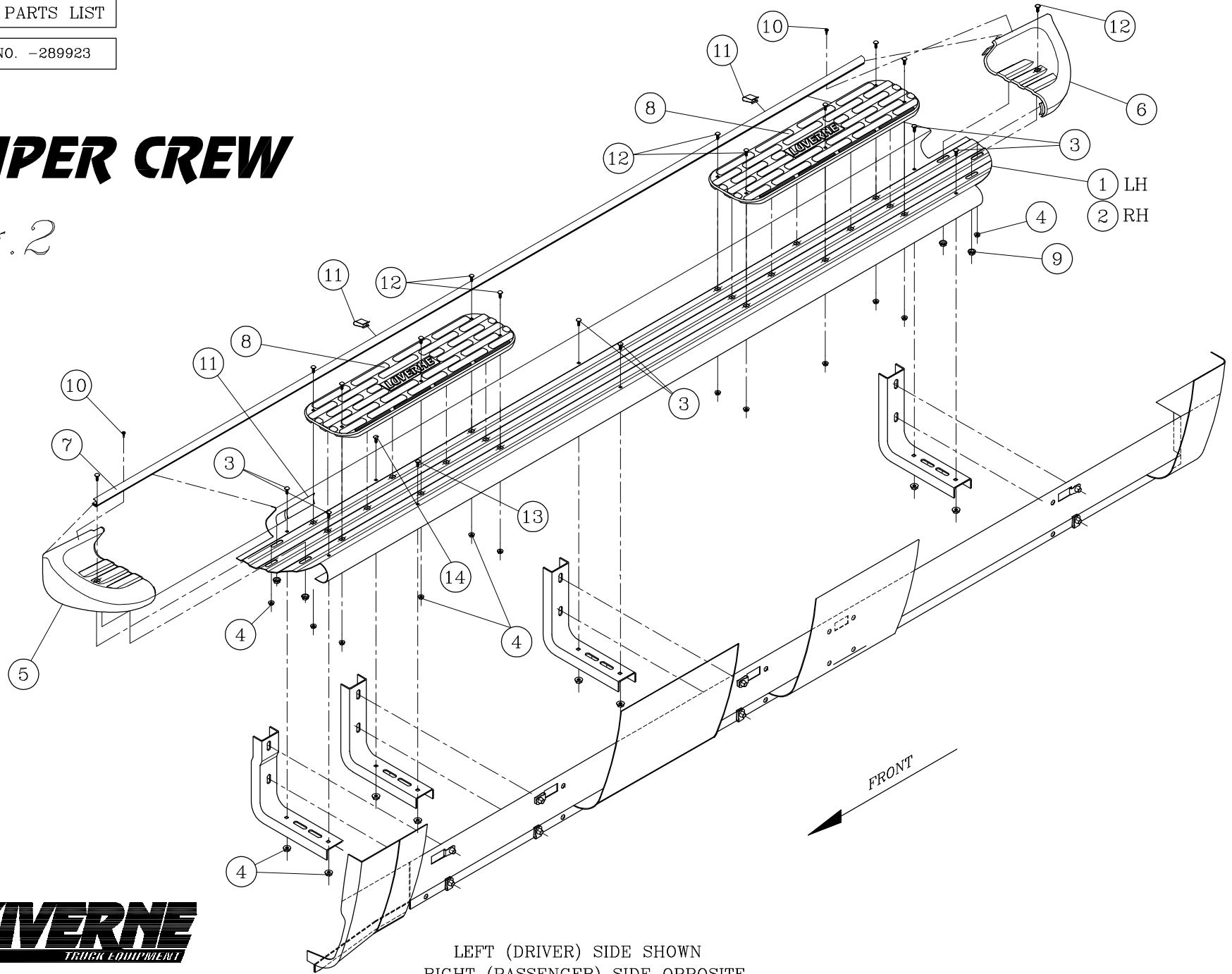

LEFT (DRIVER) SIDE SHOWN  
-RIGHT (PASSENGER) SIDE OPPOSITE-

Get in and out of your truck or SUV easier with running boards available on our website.