

INSTALLATION INSTRUCTIONS AND PARTS LIST
APPLICATION: MODEL 481521, 481522, 481523 (STAINLESS STEEL)
SIDE ENTRY STEP BOARDS ONLY:
2015+ FORD F150
REGULAR CAB, SUPER CAB, SUPERCREW

1. READ INSTRUCTIONS COMPLETELY AND CHECK TO MAKE SURE THAT ALL REQUIRED PARTS (LISTED ON SERVICE PARTS LIST) ARE ON HAND BEFORE STARTING THE INSTALLATION.
2. WITH THE STEP BOARD BRACKETS ATTACHED TO THE VEHICLE, ON THE LEFT SIDE OF THE VEHICLE PLACE THE STEP BOARD (ITEM #1) ON THE BRACKETS AND CHECK THAT THE MOUNTING HOLES LINE UP. (THE LUVERNE STICKER SHOULD BE ON THE FRONT DRIVERS SIDE)
3. INSERT THE 10-24 X .75" CARRIAGE BOLTS (ITEM #3) INTO THE BLACK NEOPRENE WASHERS (ITEM #5).
4. USING THE 10-24 X .75" CARRIAGE BOLTS (ITEM #3), AND THE 10-24 FLANGE NUTS (ITEM #4), ATTACH THE STEP BOARD TO THE BRACKETS. NOTE THAT ON THE SUPERCREW THERE IS ALREADY A CARRIAGE BOLT INSTALLED UNDER THE STEP PAD ON THE RIGHT SIDE PLATE.
5. ADJUST STEP IN/OUT TO ALIGN STEP WITH THE BODY OF THE TRUCK.
6. TIGHTEN STEP MOUNTING BOLTS.
7. REPEAT FOR RIGHT SIDE OF VEHICLE.

SERVICE PARTS LIST

ITEM	PART NO.	QTY	DESCRIPTION
1	552629	1	STEP PLATE-SES,RH,481521
2	552630	1	STEP PLATE-SES,LH,481521
1	552631	1	STEP PLATE-SES,RH,481522
2	552632	1	STEP PLATE-SES,LH,481522
1	552633	1	STEP PLATE-SES,RH,481523
2	552634	1	STEP PLATE-SES,LH,481523
3	104258	12	BOLT – CARRIAGE, 10-24 X .75", SST
4	104261	12	NUT – FLANGE, 10-24, SST
5	104530	12	WASHER-NEOPRENE, .200X.468X.03,BLACK
6	104250	2	END CAP – RH FRONT/LH REAR
7	104251	2	END CAP – LH FRONT/RH REAR
8	104255	2	TRIM – SEAL, EXTRUSION, 80.50"
9	105500	4	STEP PAD, 5.50 X 20.00
10	104257	8	NUT – HEX, SINGLE THREAD
11	107958	4	SCR-PPH, #8-18 X .5", SST
12	107645	4	CLIP-U, .118-.185, BLK
13	107863	24	BOLT – CARRIAGE, 10-24 X .5", BZP



INSTALLATION INSTRUCTIONS AND PARTS LIST
APPLICATION: MODEL 571521 MEGA STEP/SES BRACKETS ON:
2015+ FORD F150 REGULAR CAB AND EXTENDED CAB PICKUPS
ROCKER PANEL MOUNT APPLICATION



NO DRILL APPLICATION

1. READ INSTRUCTIONS COMPLETELY AND CHECK TO MAKE SURE THAT ALL REQUIRED PARTS (LISTED ON SERVICE PARTS LIST) ARE ON HAND BEFORE STARTING THE INSTALLATION.
2. ON THE LEFT SIDE OF THE VEHICLE INSTALL TWO 1.5" ISOLATOR WASHERS (ITEM #3) THE STEP MOUNTING BRACKET (ITEM #2) AND TWO M8-1.25 FLANGE NUTS (ITEM #4) ON THE FACTORY PROVIDED STUDS ON THE INSIDE OF THE ROCKER PANEL AS SHOWN IN FIGURE 1.

NOTE: IF INSTALLING STAINLESS STEEL SIDE ENTRY STEPS LEAVE THE FLANGE NUTS FINGER TIGHT ONLY TO ASSIST ALIGNMENT OF THE STEP PLATE.

3. REPEAT STEP 2 FOR THE REMAINING BRACKETS.
4. CHECK THAT ALL BRACKETS ARE LEVEL AND TIGHTEN ALL FLANGE NUTS.
5. REPEAT STEPS 2 – 4 FOR THE RIGHT SIDE OF THE VEHICLE.

ATTACHING THE STEP BOARDS TO THE BRACKETS:

PLEASE REFER TO THE INSTRUCTION SHEET INCLUDED WITH YOUR STEP BOARD ASSEMBLY TO MOUNT THE STEP TO THE BRACKETS.

SERVICE PARTS LIST

ITEM	PART NO.	QTY	DESCRIPTION
1		1	STEP ASSY, MEGA STEP / O-MEGA STEP / SES
2	552643	4	BRACKET-MTG, MEGA STEP/O-MEGA STEP/SES, 571521
3	108442	8	WASHER – NYLON, .36" X 1.5" X .032" BLACK
4	105859	8	NUT- FLANGE, M8-1.25, ZP

SERVICE PARTS LIST

MODEL NO. - 571521

2015 FORD F150 REGULAR/SUPER CAB

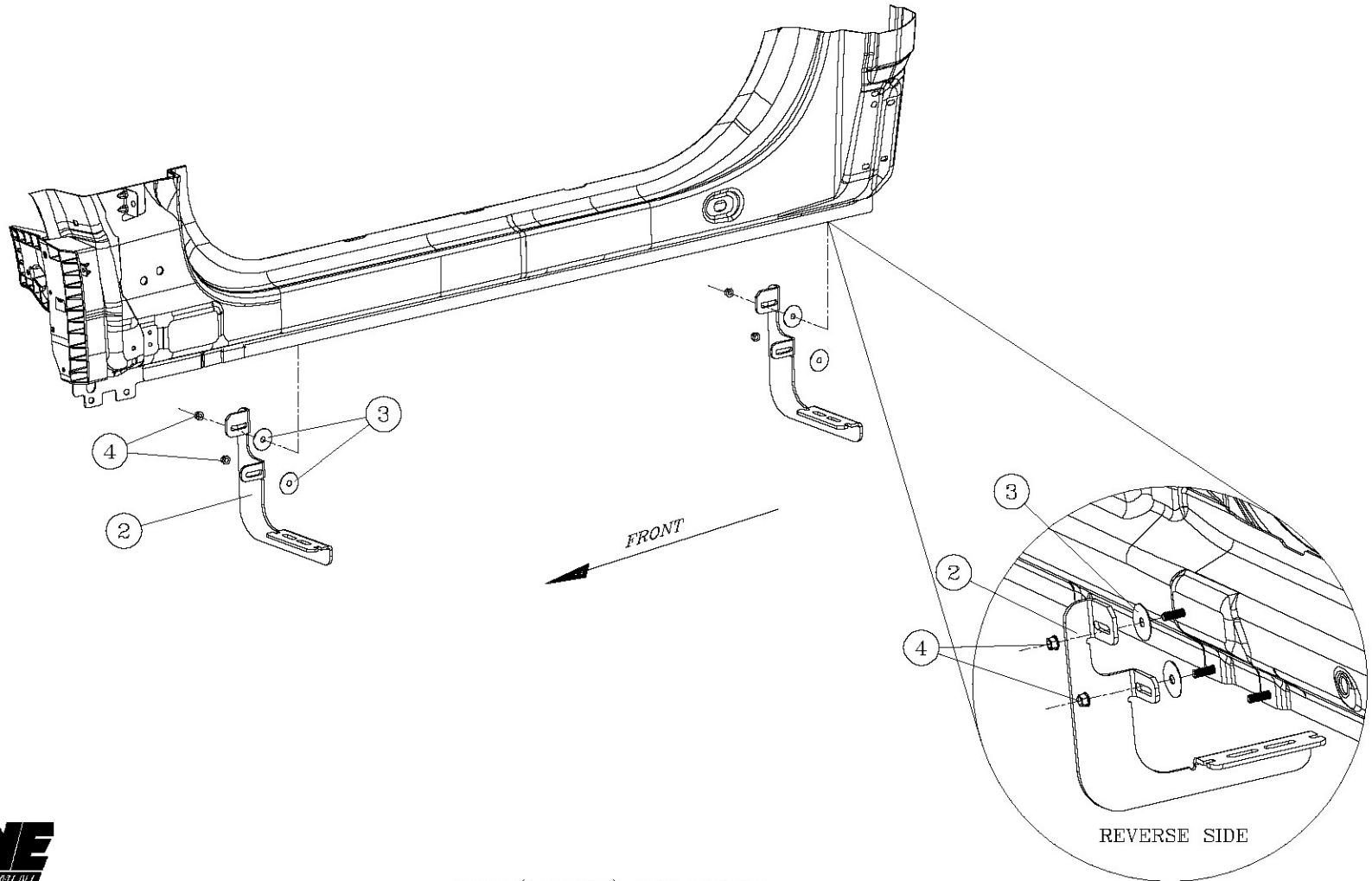

LIVERNE
TRUCK EQUIPMENT
(A LIVERNE Company)

- LEFT (DRIVERS) SIDE SHOWN -
- RIGHT (PASSENGER) SIDE OPPOSITE -

SERVICE PARTS LIST

MODEL NO. -481521
 -481522
 -481523

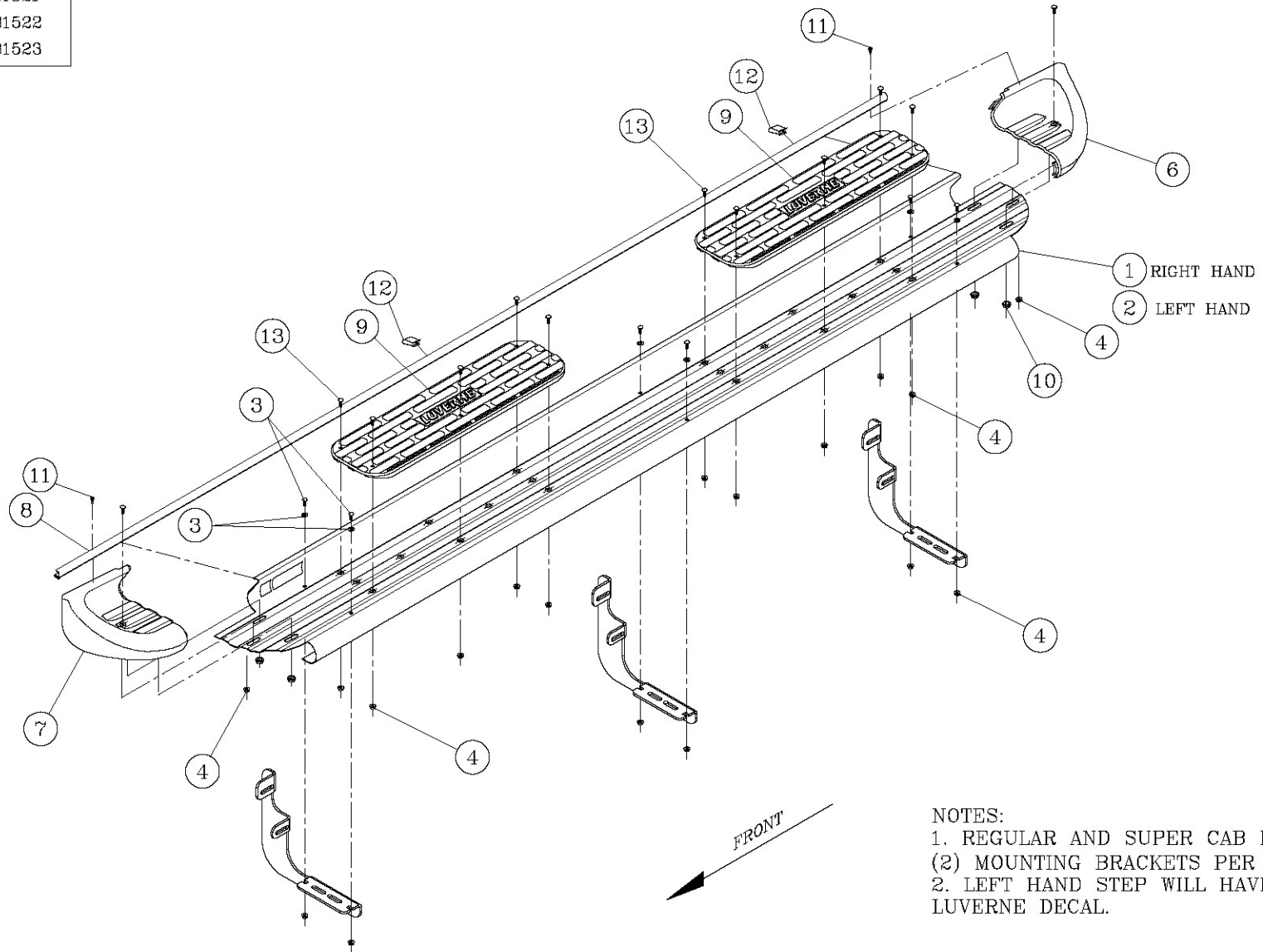

NOTES:
 1. REGULAR AND SUPER CAB HAVE ONLY
 (2) MOUNTING BRACKETS PER SIDE.
 2. LEFT HAND STEP WILL HAVE THE
 LUVERNE DECAL.



LEFT (DRIVER) SIDE SHOWN
 -RIGHT (PASSENGER) SIDE OPPOSITE-

Choose reliable running boards offered on our website.