

INSTALLATION INSTRUCTIONS AND PARTS LIST

APPLICATION: MODEL 280743/281442 (BLACK) SIDE ENTRY STEP BOARDS:
ROCKER PANEL MOUNT APPLICATION

1. READ INSTRUCTIONS COMPLETELY AND CHECK TO MAKE SURE THAT ALL REQUIRED PARTS (LISTED ON SERVICE PARTS LIST) ARE ON HAND BEFORE STARTING THE INSTALLATION.
2. WITH THE STEP BOARD BRACKETS ATTACHED TO THE VEHICLE, ON THE LEFT SIDE OF THE VEHICLE PLACE THE STEP BOARD (ITEM #1) ON THE BRACKETS AND CHECK THAT THE MOUNTING HOLES LINE UP. (THE LUVERNE STICKER SHOULD BE ON THE FRONT DRIVERS SIDE)
3. USING SEVEN (7) 10-24 X .75" CARRIAGE BOLTS (ITEM #3), AND EIGHT (8) 10-24 FLANGE NUTS (ITEM #4) ATTACH THE STEP BOARD TO THE BRACKETS.

NOTE: ON THE 280743 CREW CAB APPLICATION, ONE CARRIAGE BOLT SHOULD ALREADY BE INSTALLED UNDERNEATH THE REAR STEP PAD.

4. ADJUST STEP IN/OUT TO ALIGN STEP WITH THE CAB.
5. TIGHTEN STEP MOUNTING BOLTS.
6. REPEAT FOR RIGHT SIDE OF VEHICLE.

SERVICE PARTS LIST

ITEM	PART NO.	QTY	DESCRIPTION
1	552929	1	STEP PLATE-SES,LH,280743
2	552930	1	STEP PLATE-SES,RH,280743
1	552927	1	STEP PLATE-SES,LH,281442
2	552928	1	STEP PLATE-SES,RH,281442
3	109685	14	BOLT – CARRIAGE, 10-24 X .75", SST, BLK
4	104258	2	BOLT–CARRIAGE, 10-24 X .75", SST
5	104261	40	NUT – FLANGE, 10-24, SST
6	104250	2	END CAP – RH FRONT/LH REAR
7	104251	2	END CAP – LH FRONT/RH REAR
8	102502	2	TRIM – SEAL, EXTRUSION, 95"
9	105500	4	STEP PAD, 5.50 X 20.00
10	104257	8	NUT – HEX, SINGLE THREAD
11	107958	4	SCR-PPH, #8-18 X .5", SST
12	107645	4	CLIP-U, .118-.185,BLK
13	107863	24	BOLT – CARRIAGE, 10-24 X .5", BZP



INSTALLATION INSTRUCTIONS AND PARTS LIST

APPLICATION: MODEL **581443** (STAINLESS STEEL) SIDE ENTRY STEP BRACKETS ON:
2015 GM 1500 CREW CAB PICKUPS, GAS
2015 GM 2500/3500HD CREW CAB PICKUPS, GAS
ROCKER PANEL MOUNT APPLICATION



NO DRILL APPLICATION

1. READ INSTRUCTIONS COMPLETELY AND CHECK TO MAKE SURE THAT ALL REQUIRED PARTS (LISTED ON SERVICE PARTS LIST) ARE ON HAND BEFORE STARTING THE INSTALLATION. THE SIDE ENTRY STEP ASSEMBLIES SHOULD BE MOUNTED TO THE PINCH WELD AND VERTICAL WALL OF THE ROCKER PANEL AS FOLLOWS. **NOTE: DEPENDING ON THE VEHICLE, THE HOLE CONFIGURATION MAY CHANGE. FASTENERS ARE PROVIDED FOR ALL APPLICATIONS.**
2. ON THE LEFT SIDE OF THE VEHICLE REMOVE THE PLASTIC BODY PLUGS THAT ARE LOCATED ON THE VERTICAL WALL OF THE ROCKER PANEL AND INSERT A 5/16"-18 U-NUT (ITEM #6) AS SHOWN. **NOTE: IF THERE ARE THREADED INSERTS IN THE UPPER LOCATION, USE THE BLACK M8-1.25X30 BOLTS (ITEM #8).**
3. POSITION THE MOUNTING BRACKETS (ITEM #2) SO THAT THE HOLES ON THE BRACKET LINE UP WITH THE HOLES ON THE INSIDE WALL OF THE ROCKER PANEL. INSTALL EITHER A BLACK M8-1.25 X 30 MM HEX BOLT (ITEM #8) OR A 5/16"-18 X 1.00" HEX BOLT (ITEM #5), AND A 5/16" FLAT WASHER (ITEM #4), FINGER TIGHT.
4. INSTALL A BLACK M8-1.25 X 30 MM HEX BOLT, 5/16" FLAT WASHER, AND THE PINCH WELD SUPPORT (ITEMS #4, 7, 8) THROUGH THE LOWER HOLE AND INSTALL A M8-1.25 NUT (ITEM #9) FINGER TIGHT ON THE BACK AS SHOWN.
5. REPEAT STEPS 3 – 4 FOR THE REMAINING BRACKETS.
6. INSTALL THE STEP BOARD AS DESCRIBED BY THE INSTRUCTIONS INCLUDED WITH YOUR STEP BOARDS.
7. PRESS STEP DOWN AND BACK, TIGHTEN THE MOUNTING BOLTS TO 19 LB-FT STARTING WITH THE BOTTOM BOLTS FOLLOWED BY THE TOP BOLTS.
8. REPEAT STEPS 2 – 7 FOR THE RIGHT SIDE OF THE VEHICLE.

SERVICE PARTS LIST

ITEM	PART NO.	QTY	DESCRIPTION
1	480743	1	STEP ASSEMBLY, SES, (MOD 480743)
2	552626	4	BRKT-MTG, LH, SES/MS 07+ GM PICKUPS
3	552625	4	BRKT-MTG, RH, SES/MS, 07+ GM PICKUPS
4	106698	16	5/16" – FLATWASHER, SST, BZP
5	100647	8	5/16"-18 X 1.00" SCR ZP
6	105541	8	U-NUT,5/16"-18
7	551666	8	BRKT-MTG,PINCH WELD SUPPORT
8	100180	12	M8-1.25X30, HEX SCREW, SST, BZP
9	105859	8	NUT-HEX FLNG, M8-1.25, ZP



(A LUVERNE Company)

SERVICE PARTS LIST

MODEL NO. - 581443

GM CREW CAB

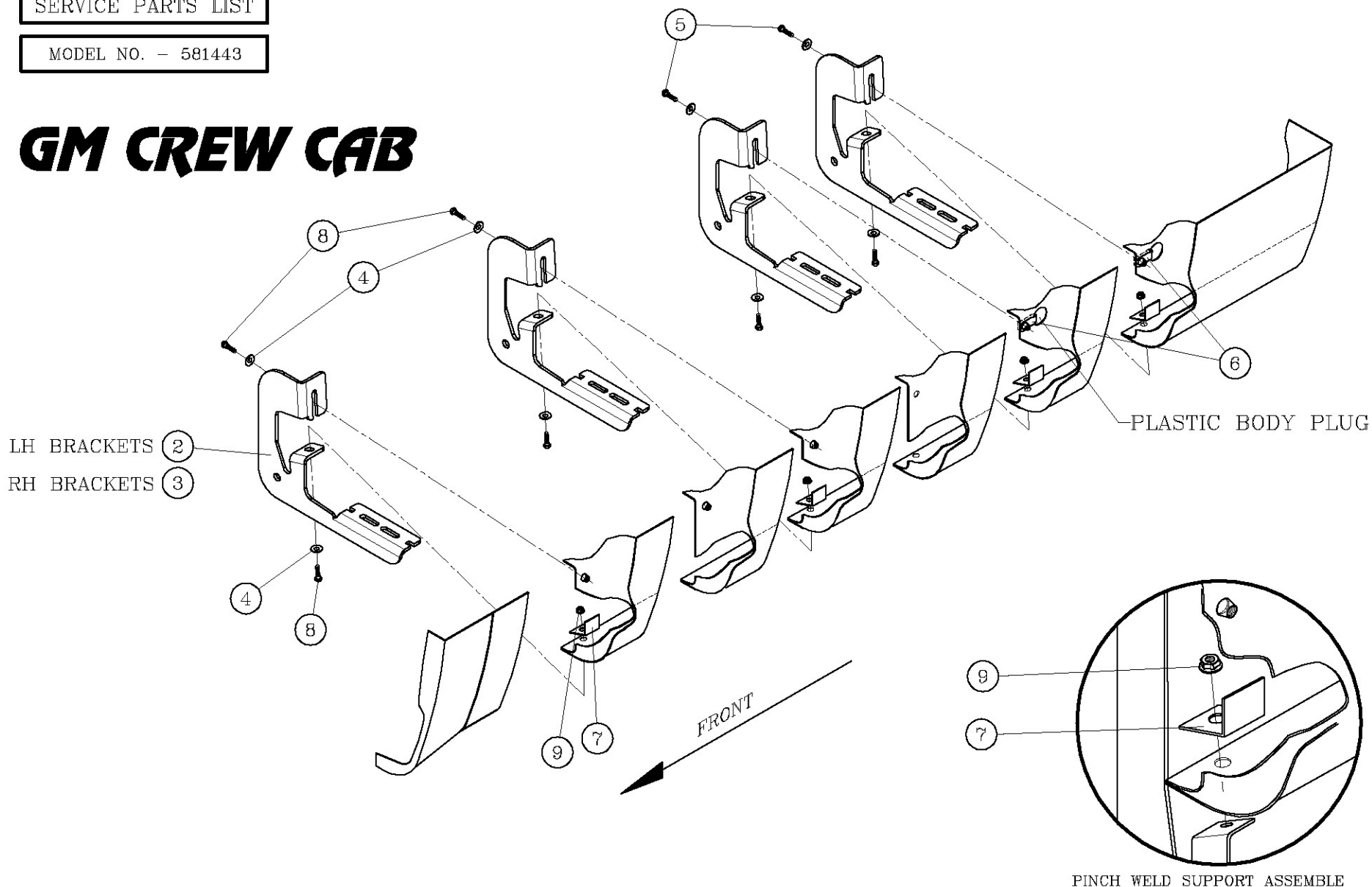

LEFT (DRIVER) SIDE SHOWN
-RIGHT (PASSENGER) SIDE OPPOSITE-

SERVICE PARTS LIST

MODEL NO. - 280743

GM CREW CAB

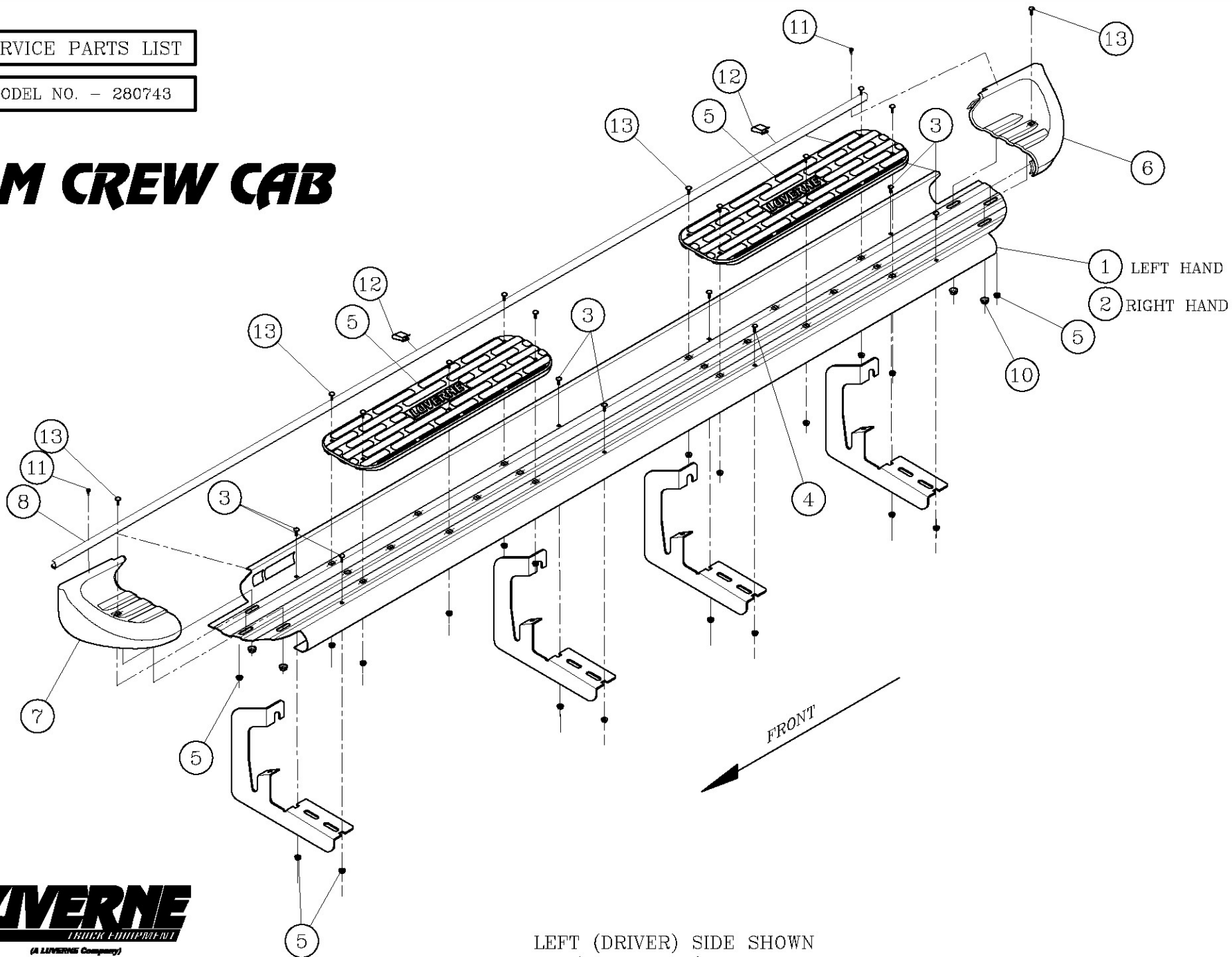

LEFT (DRIVER) SIDE SHOWN
-RIGHT (PASSENGER) SIDE OPPOSITE-

SERVICE PARTS LIST

MODEL NO.-281442

GM DOUBLE CAB

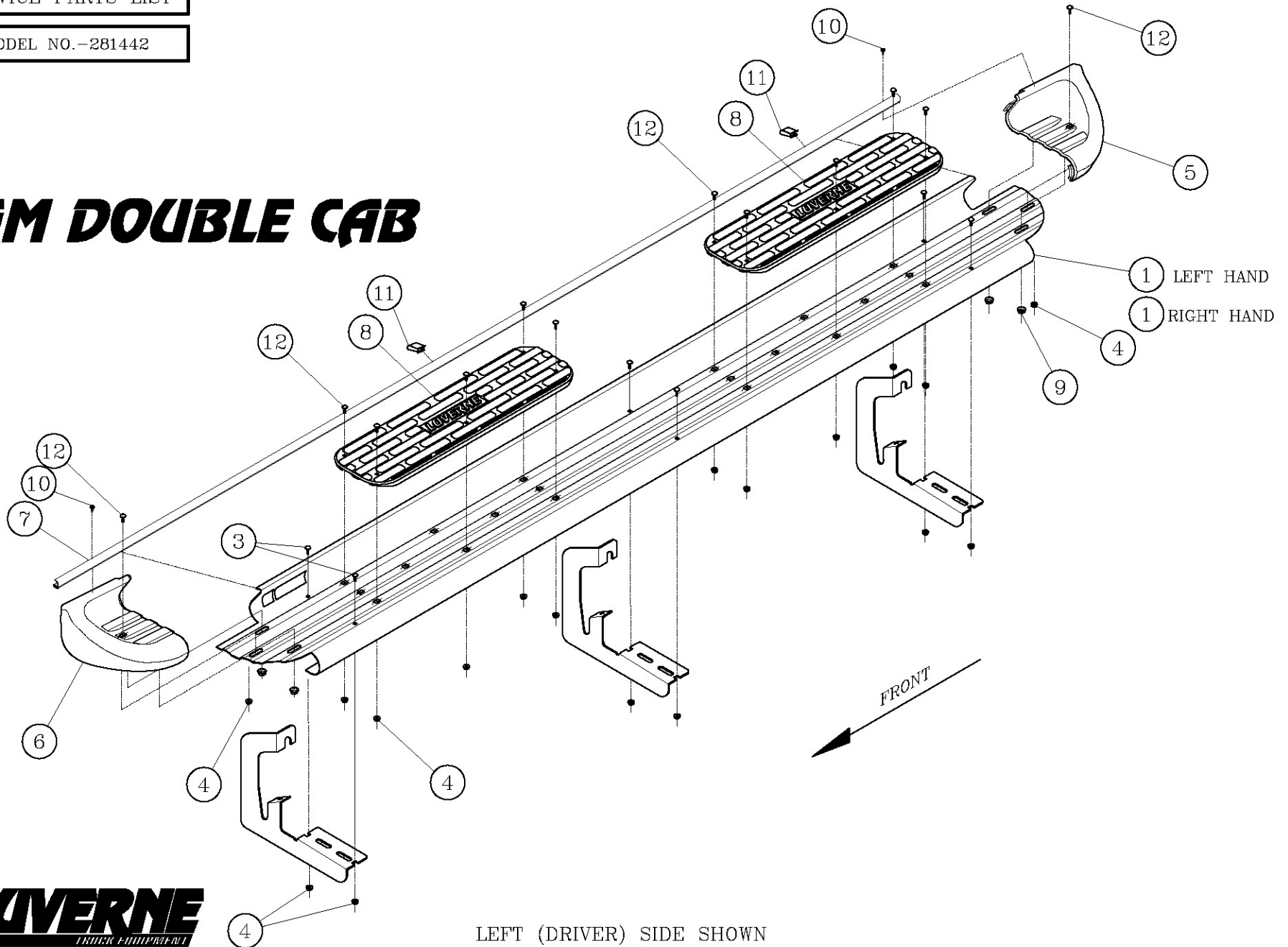

LEFT (DRIVER) SIDE SHOWN
-RIGHT (PASSENGER) SIDE OPPOSITE-