

Installation Instructions

LUND®

Premium Style. Lasting Performance.

Genesis™ and Genesis Elite™ Tri-Fold Tonneau Cover

For proper installation and best possible fit, please read all instructions BEFORE you begin.

Important Safety Information



- Serious personal injury and property damage can occur if vehicle is driven without both black buckles at the front of cover fastened.
- Prior to vehicle operation, clamps must be secured such that the clamp lips tightly grip the inner bedwall structure.
- Only release buckles when fully installing cover.
- After a setting period (1 week) it may be necessary to readjust the clamp load after foam isolators take a set to maintain the uniform gap between the Genesis™ Tri-Fold Tonneau cover and bed rails.
- Check the bracket clamp loads every 3 months or 5,000 miles.
- The Genesis™ Tri-Fold Tonneau cover must be closed or secured with straps while the vehicle is in motion.

Contents **NOTE: Actual product may vary from illustration.**

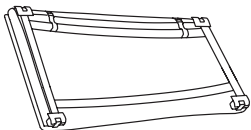

Tri-Fold Cover Assembly

(A)

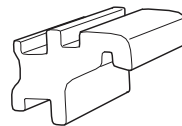

4 x Adapter

(B)

Hardware maybe packed in tube dun age. Check dun age for hardware before discarding.

Tools Required



Car Wash Supplies

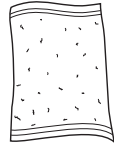

Clean Towel

Preparation Before Installation

- Wash the upper rail surfaces of the truck bed.
- Be sure to completely dry the washed surfaces before installing the tonneau cover.

NOTE: Actual application may vary slightly from illustrations.

Installation Steps

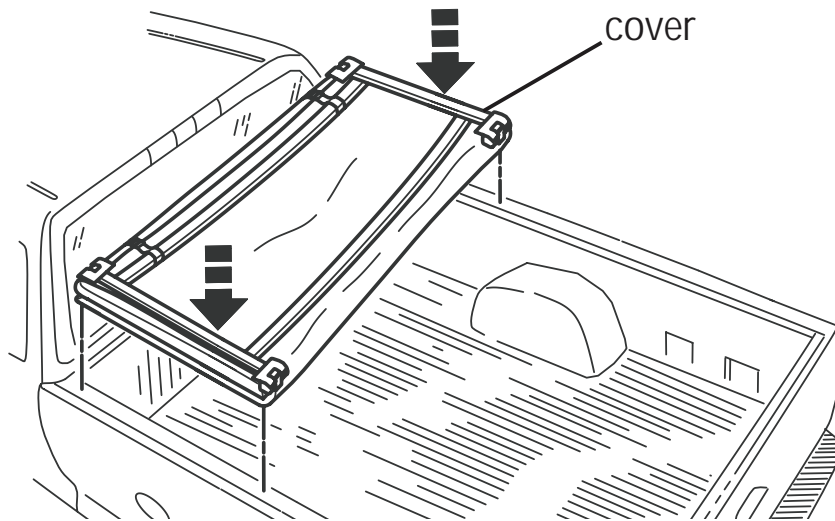

Place the cover assembly on the top of the truck bed next to the cab.

1

Installation Steps

NOTE: Actual application may vary slightly from illustrations.

Line up to front of bed first. Center the cover assembly on the truck. Position the cover assembly so the gaps on all sides are equal.

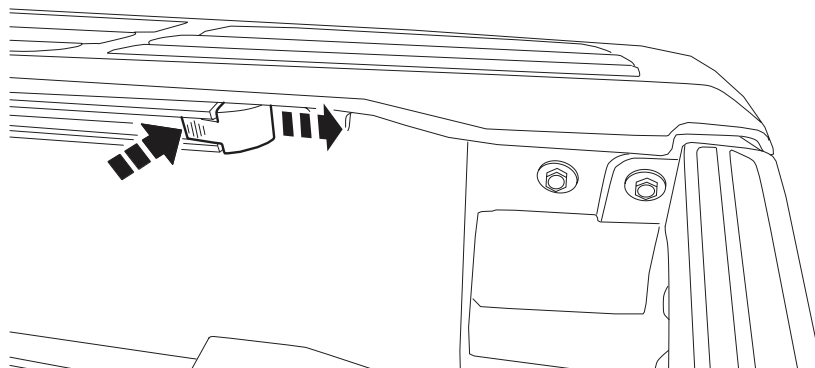
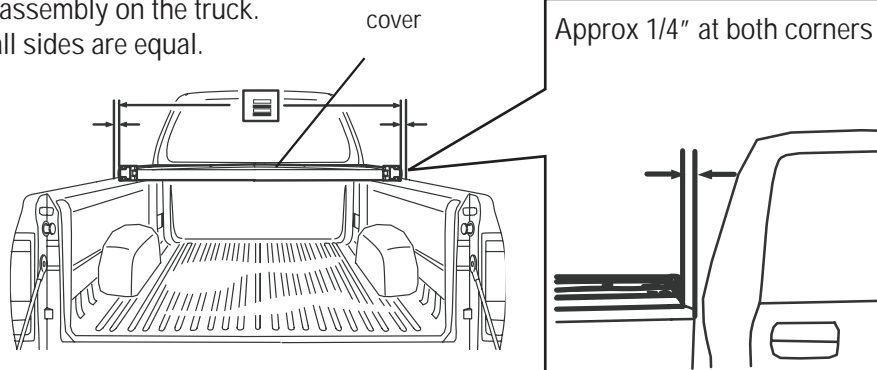

Remove plastic caps from the ends of the channels on both sides of the vehicle. Push tab in while sliding out.

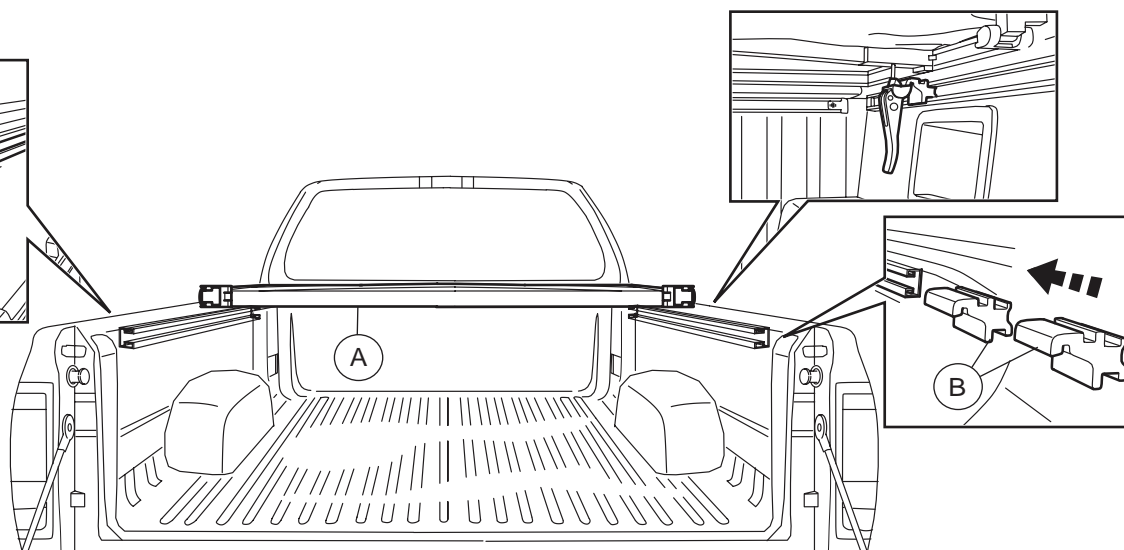
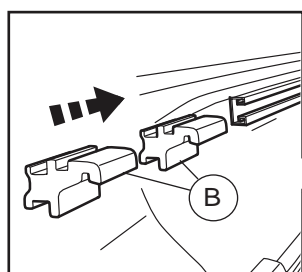

Insert 2 adaptors (Item B) into each bed sidewall track. Slide one adaptor in each track forward until they are centered with both front cover clamps (Item A). Re-install caps removed in Step 3.

Installation Steps

NOTE: Actual application may vary slightly from illustrations.

Secure both front clamps.

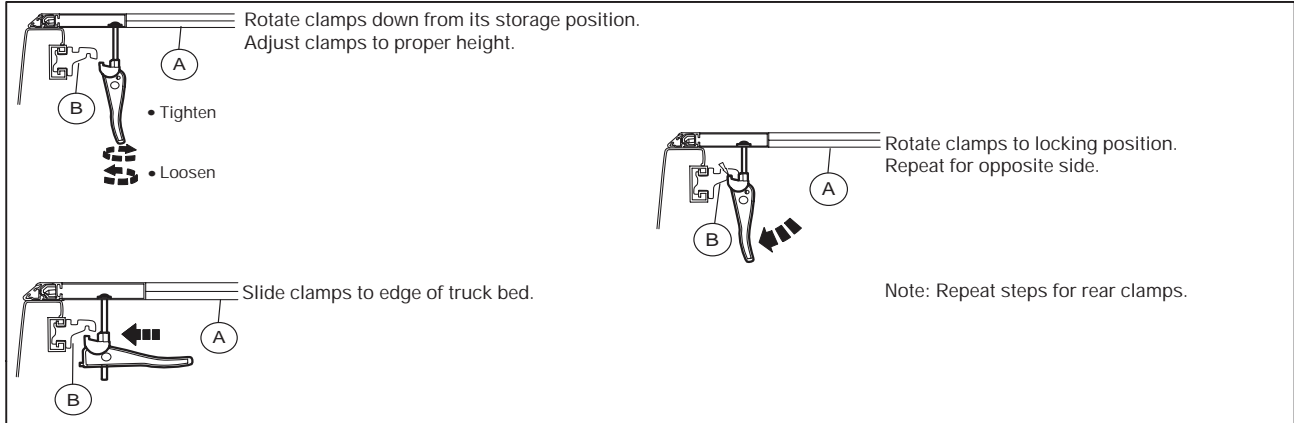
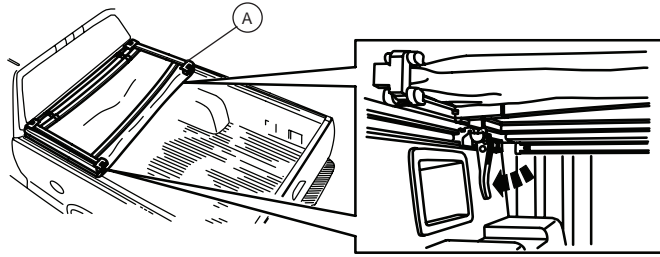

Warning: Prior to vehicle operation, inspect clamps to make sure the lip on clamp is properly seated in the utility track adaptors.

5

The cover has retaining straps with quick-release buckles to keep it from being damaged when bulk hauling or when it is not on the vehicle.

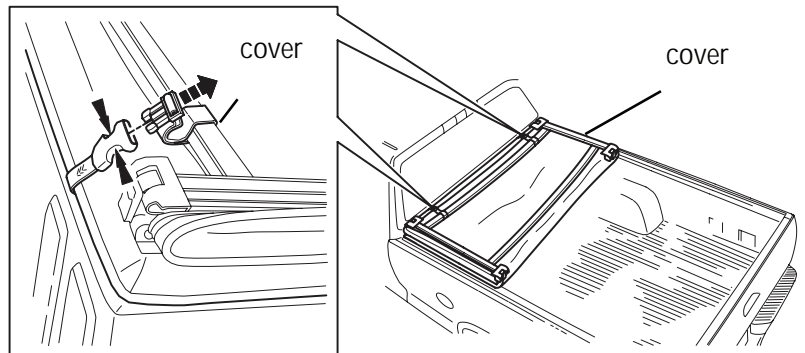

6

7A Unfold second section of the cover

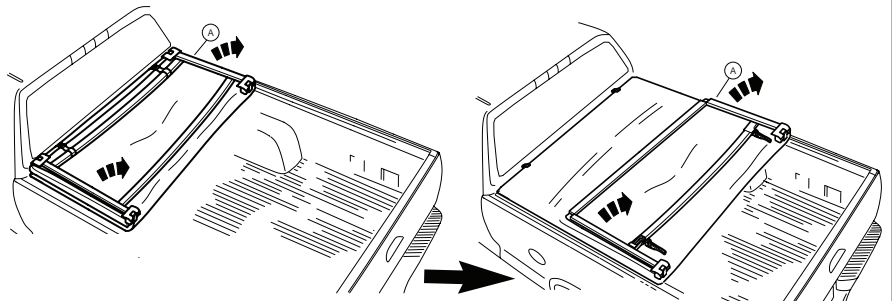

7B Make sure there is no dust or debris on the rear rail.

7C Unfold third section of the cover.

7

NOTE: Actual application may vary slightly from illustrations.

Installation Steps

Securing Both Rear Clamps

NOTE: Clamp handle must rotate completely down to the stop to be locked. If something interferes with the handle (bed liner, bed extender or cargo, etc.) it must be modified or removed.

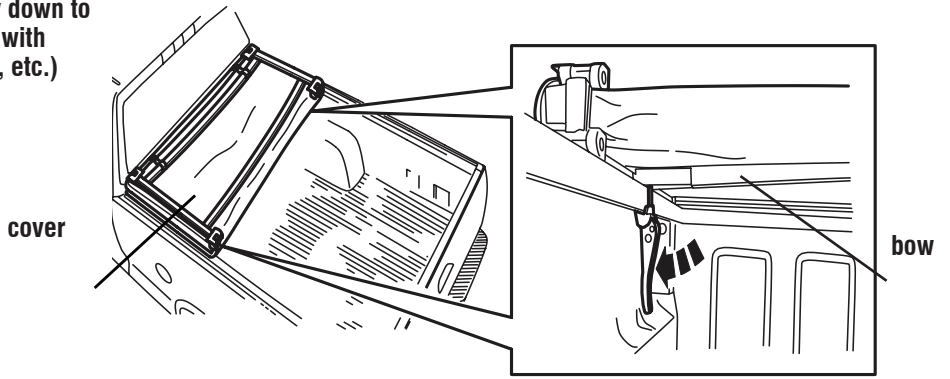

8

Rotate each clamp down from its storage position.

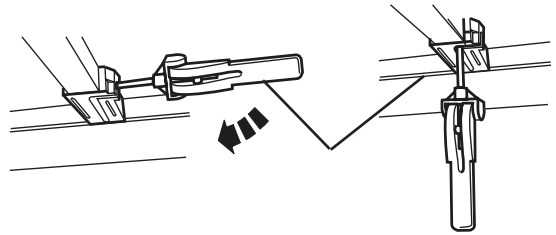

9

Adjust clamps to proper height. Make sure that the inner bedwall structure and clamp lid are aligned as shown by dashed line. Handle height should be adjusted, such that the clamp contacts the bed rail flange while the handle is in the 4 o'clock (LH) or 8 o'clock (RH) position.

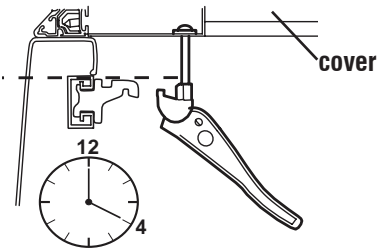

• Raise to Tighten (Up)

• Lower to Loosen (Down)

10

Rotate handles back up and slide clamps to edge of truck bed as shown. For ease of sliding outward, the latch handle should be in this position until the clamp engages the bed flange.

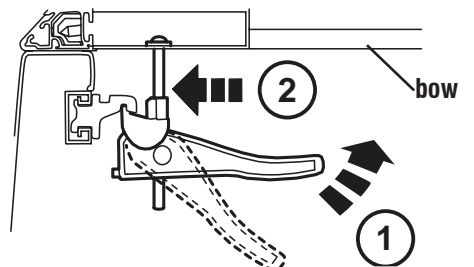

Reverse process for folding and stowing cover.

11

Rotate clamps to locking position. Repeat for opposite side. Note: A light to moderate force should be felt when latching to the truck bed. The latches should NOT be loose when in the LOCKED POSITION.

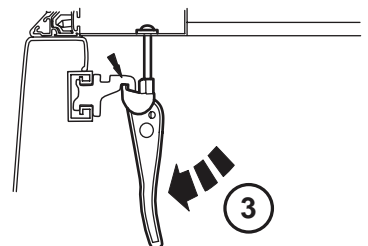

Reverse process for folding and stowing cover.

12

Installation Steps

NOTE: Actual application may vary slightly from illustrations.

After clamping Tonneau inspect clamps to make sure the pinch weld is seated properly in the notch on the clamp. Trim the bed cap at the clamp location if it extends down past the metal.

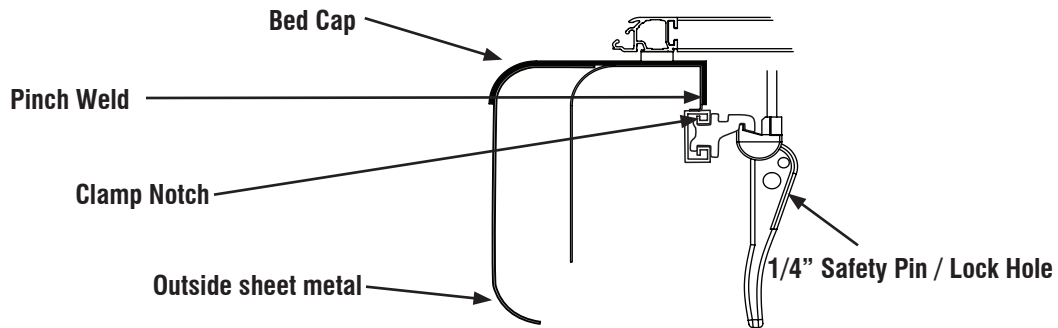

If traveling with the Tonneau in the folded position it is recommended to use a safety pin or lock in the front clamps.

13

Securing Front Clamps - Fold Cover Forward

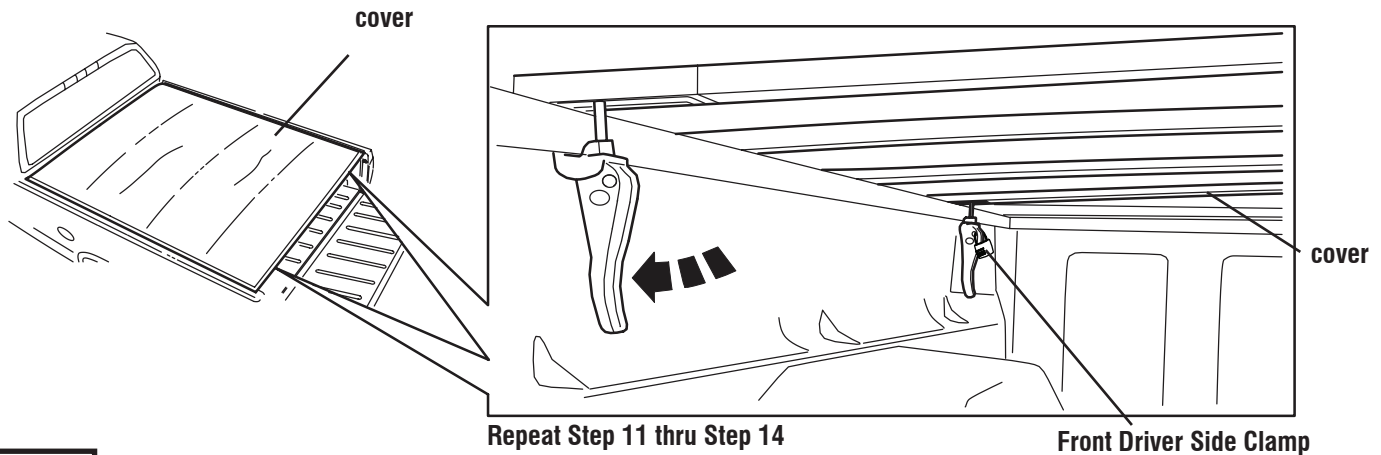

14

Unlatching and Securing Latches for Folding and Stowing Center

Rotate clamp up from its install position into its storage position as shown. Make sure that latch handle matches illustration on bow caution label.

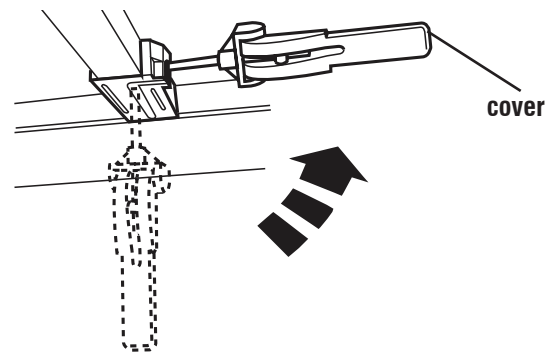

15

Installation Steps

NOTE: Actual application may vary slightly from illustrations.

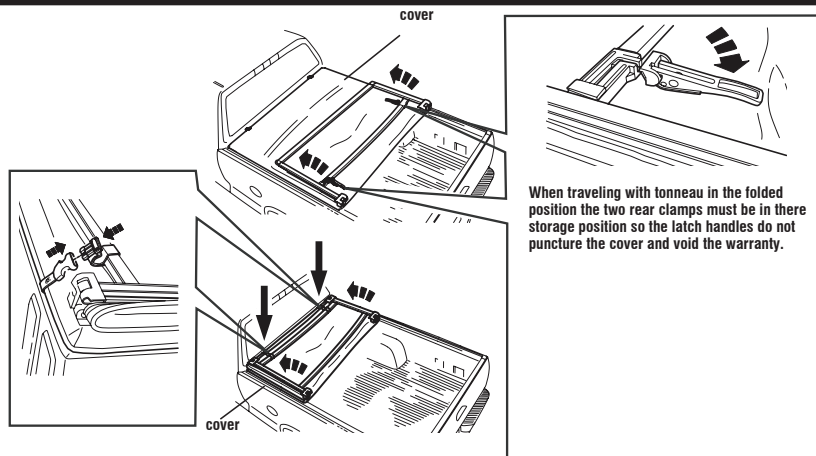

16

The retaining straps must be buckled when vehicle is in motion if Tonneau is in the folded position.

Care and Cleaning

- Wash only with mild soap & dry with a clean cloth.
- Avoid the use of automatic “brush-syle” car washes.
- Do not use cleaning solvents of any kind.
- Pressure car washes are okay as long as you hold the wand no closer than two feet from the cover.
- We recommend the same quality products normally used for vinyl tops to keep the cover clean. When using a protectant, be sure that it is water based.

Congratulations!

You have purchased one of the many quality Lund[®] branded products offered by Lund International, Inc. We take the utmost pride in our products and want you to enjoy years of satisfaction from your investment. We have made every effort to ensure that your product is top quality in terms of fit, durability, finish and ease of installation.