



## OE Style No Drill Bracket

For proper installation and best possible fit, please read all instructions BEFORE you begin.

### Important Safety Information



- To be used with Lund® branded products only.
- Do not stand on Lund [running board](#) or bracket while vehicle is in motion.
- Do not exceed 350 lbs. weight on the Lund bracket system.
- Do not use the brackets as a jacking point for the vehicle.
- Do not use the bracket system or running boards to fasten cargo.
- Periodically check all components for tightness.
- Be sure to wear safety glasses while installing brackets.
- When using power tools, read and understand all operating instructions.

### Contents

**NOTE:** Actual product may vary from illustration. Not all supplied fasteners used in this application.

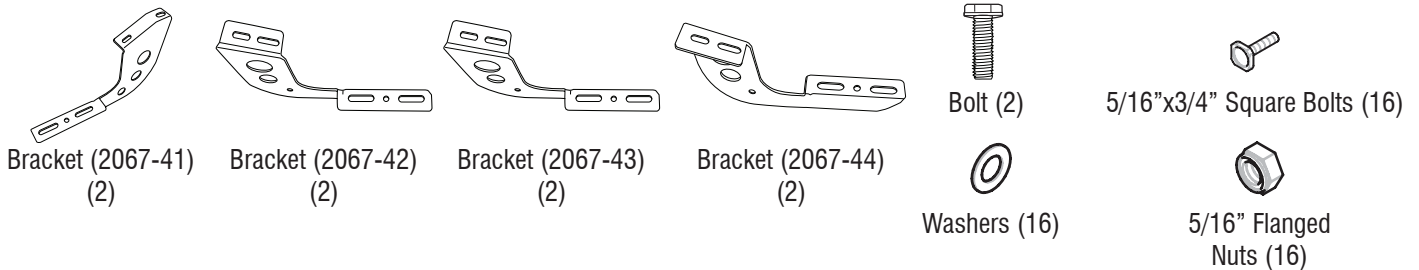

### Tools Required



Safety Glasses



Socket Wrench



Socket Set

### Preparation Before Installation

- Park your vehicle in a clean, level location. Check to make sure the vehicle is in park, or for manual drive models, place the transmission in first gear. Engage the parking brake.
- Unpack the bracket kit and identify the parts according to the content descriptions.

### Installation Steps

**NOTE:** Actual application may vary slightly from illustrations.

Identify the mounting location for the front bracket (2067-41) by looking under the vehicle and locating the front mounting location as shown in the diagram below. Remove black rubber grommet covering threaded hole.

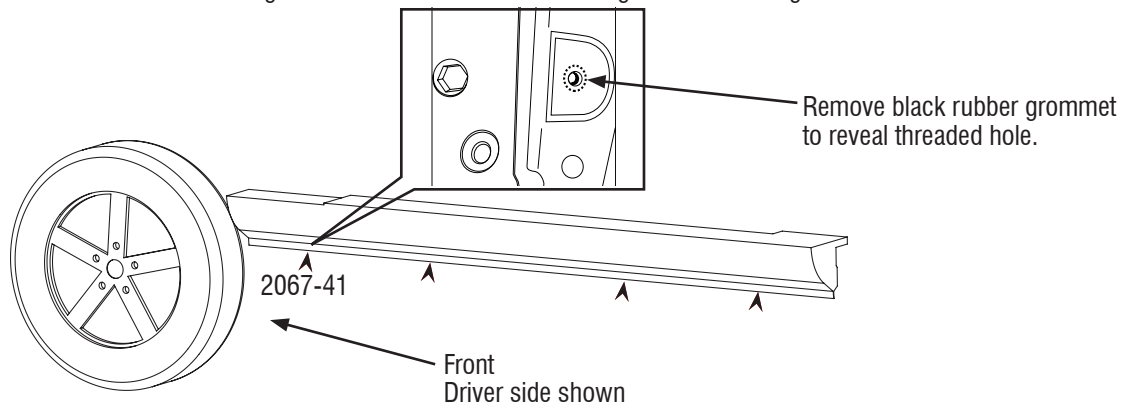

# Installation Steps

**NOTE:** Actual application may vary slightly from illustrations.

Remove bolt.

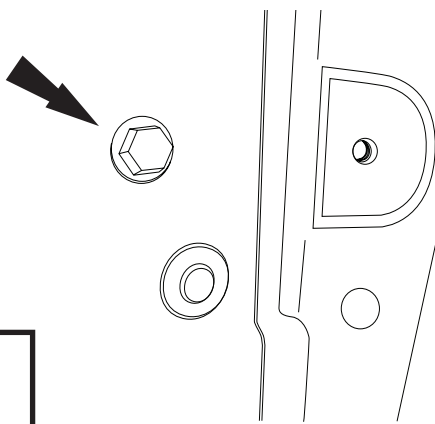

2



Align bracket 2067-41 with holes as shown.

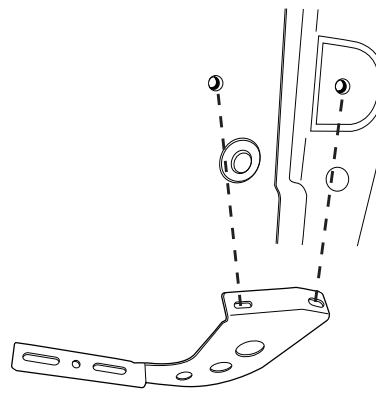

3

Secure bracket to vehicle by reinstalling factory bolt previously removed in **Step 2** at location shown.

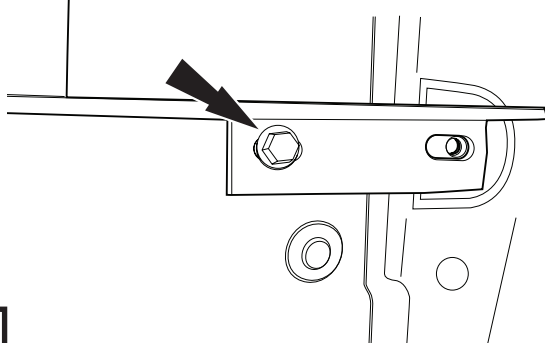

4

**NOTE:** Hand tighten only at this stage.



Use one (1) of the supplied bolts to complete front bracket installation by securing through remaining hole.

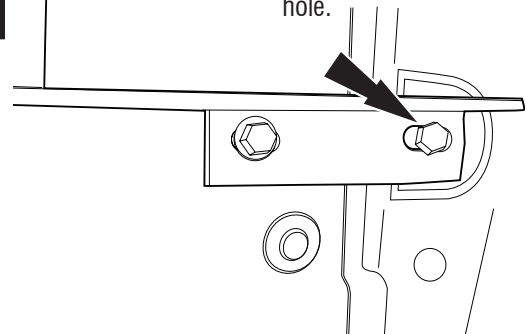

5

**NOTE:** Hand tighten only at this stage.

Identify the mounting location for the second (2067-42) and third (2067-43) brackets by looking under the vehicle and locating the mounting bolts as shown in the diagram below.

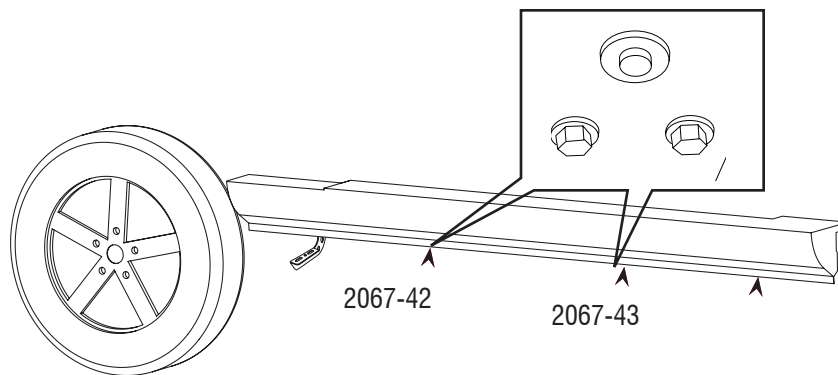

6

Remove two (2) bolts.

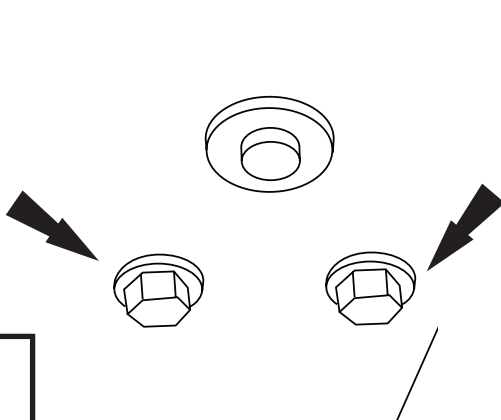

7

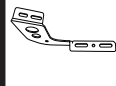

Align brackets with holes as shown. Reinstall previously removed bolts and secure bracket to vehicle.

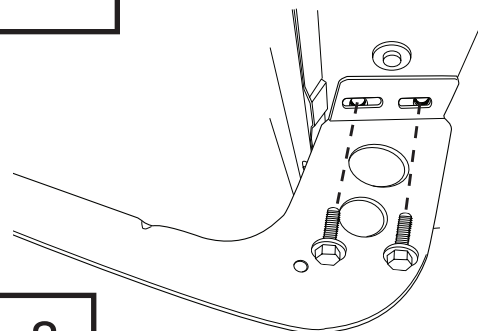

8

**NOTE:** Hand tighten only at this stage.

# Installation Steps **NOTE:** Actual application may vary slightly from illustrations.

Identify the mounting location for the fourth (2067-44) bracket by looking under the vehicle and locating the mounting bolts as shown in the diagram below.

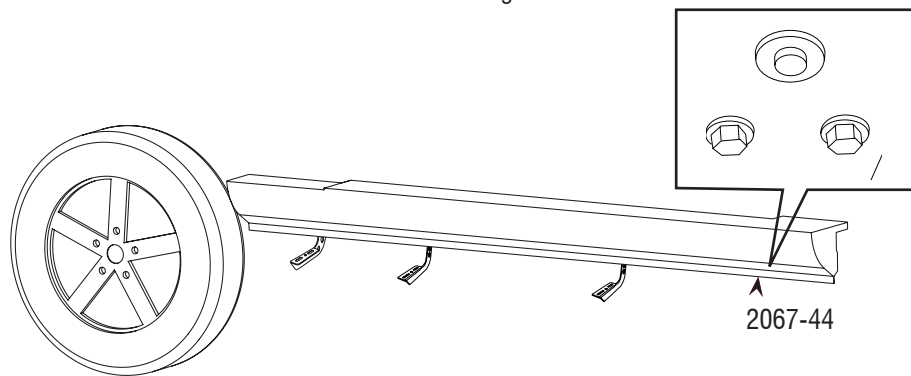

9

Remove two (2) bolts.

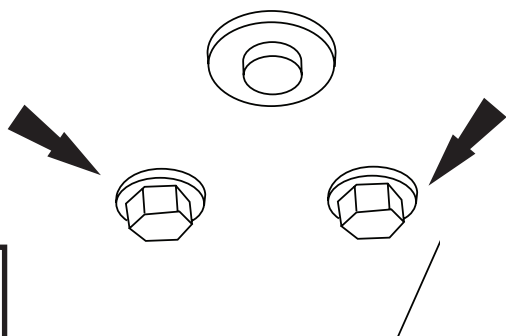

10

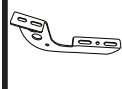

Align bracket with holes as shown. Reinstall previously removed bolts and secure bracket to vehicle.

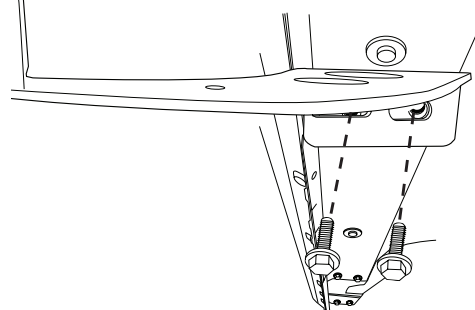

11

NOTE: Hand tighten only at this stage.

Repeat steps 1 thru 12 for passenger side. Go back and final tighten all bolts.

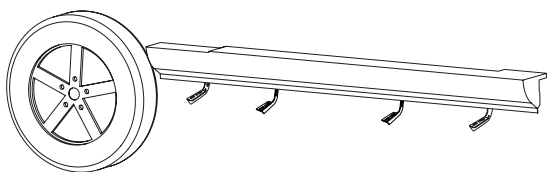

12



Install square bolts into the shaded outer channels. Four (4) per channel to attach boards to brackets.

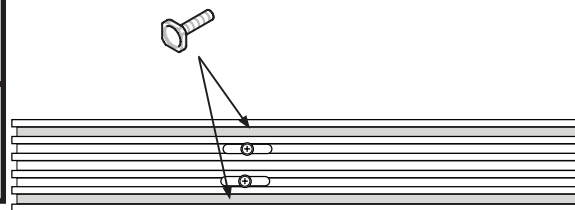

13

Attach boards to brackets.

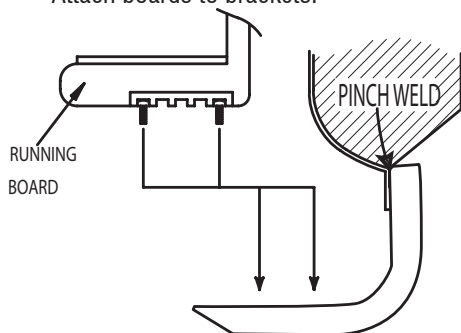

14

Washer →  
5/16" Flanged Nut →