

Installation Instructions

I - Sheet Number 45267 Rev.E

LUND®

EZ Bracket

For proper installation and best possible fit, please read all instructions BEFORE you begin.

Important Safety Information



- To be used with Lund® branded products only.
- Do not stand on Lund [running board](#) or bracket while vehicle is in motion.
- Do not exceed 350 lbs. weight on the Lund bracket system.
- Do not use the brackets as a jacking point for the vehicle.
- Do not use the bracket system or running boards to fasten cargo.
- Periodically check all components for tightness.
- Be sure to wear safety glasses while installing brackets.
- When using power tools, read and understand all operating instructions.

Contents

NOTE: Actual product may vary from illustration.

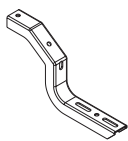

Front Bracket

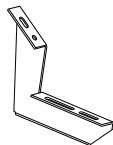

Back Bracket

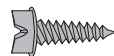

#14 x 1 Self Tapping Screws

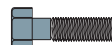

1/4" bolts

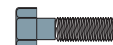

8mm bolts



1/4" Washers



1/4" Nuts

Tools Required



Socket Set
J

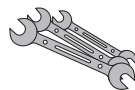

Standard Wrench Set

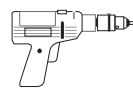

Drill



Hammer

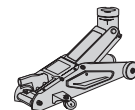

Floor Jack



5/16" Drill Bit



1/8" Drill Bit



Silicone



Center Punch

Preparation Before Installation

- Park your vehicle in a clean, level location. Check to make sure the vehicle is in park, or for manual drive models, place the transmission in first gear. Engage the parking brake.
- Unpack the bracket kit and identify the parts according to the content descriptions.

Installation Steps

NOTE: Actual application may vary slightly from illustrations.

NOTE: Place truck on level surface.

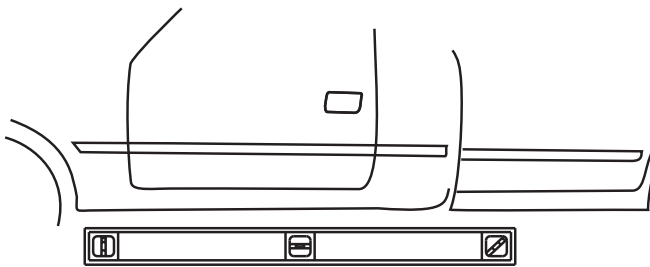

1

NOTE: Preassemble boards according to running board instruction sheet.

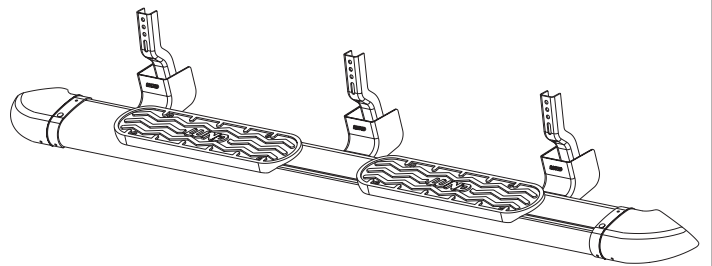

P.N. 300022 = 6 Brackets / side

P.N. 300023 = 4 Brackets / side

2

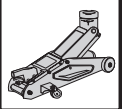

NOTE: Raise board into place with floor jack. Center board on rocker panel.

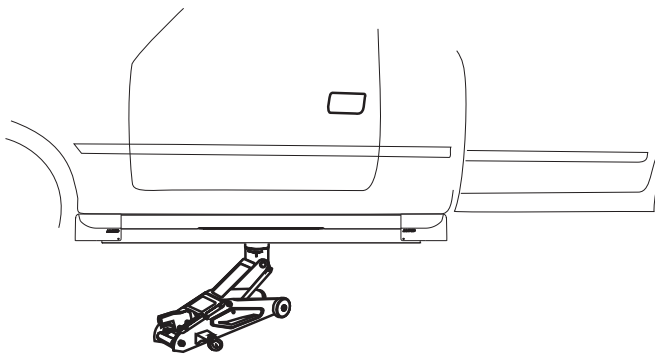

3



NOTE: Using front bracket as a guide, mark all hole locations in rocker panel if factory holes not present.

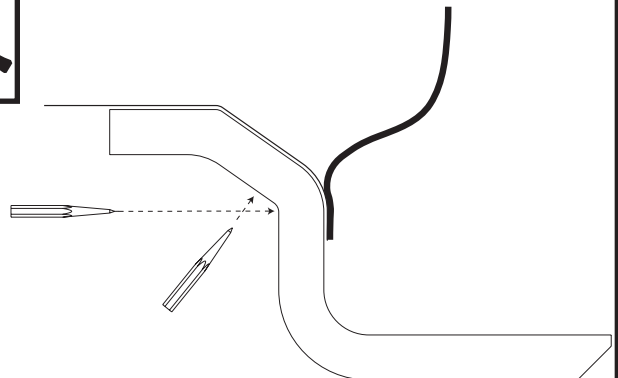

4

FRONT ADELANTE AVANT

Installation Steps

NOTE: Actual application may vary slightly from illustrations.



NOTE: Using back bracket as a guide, mark all hole locations in rocker panel if factory holes not present.

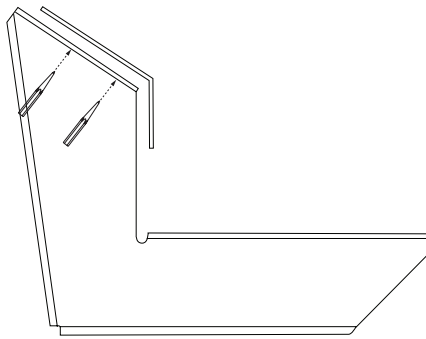

5

BACK ATRÁS ARRIÈRE

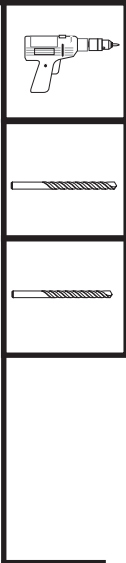

NOTE: Lower board and drill upper holes 1/8" diameter and lower 5/16" diameter if factory holes not present.



6

FRONT ADELANTE AVANT

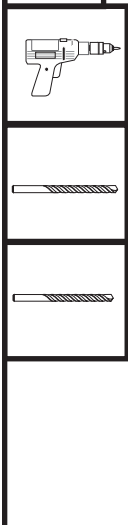

NOTE: Lower board and drill upper holes 1/8" diameter if factory holes not present.

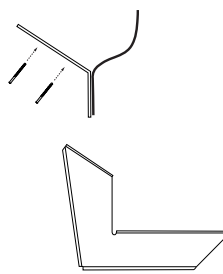

7

BACK ATRÁS ARRIÈRE



NOTE: Place a small bead of silicon in each hole.

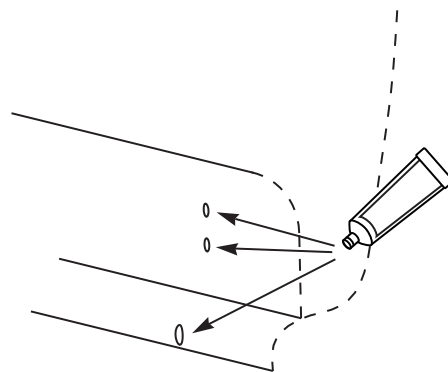

8

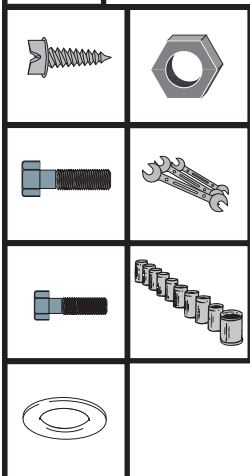

NOTE: Raise board to vehicle and install 8mm bolt and finger tighten, install screws in to rocker panel and tighten by hand. Install 1/4" bolt in rocker panel and finger tighten. Once all fasteners are installed tighten all fasteners with tools noted.

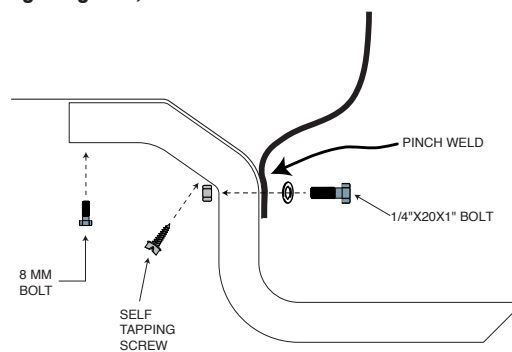

9

FRONT ADELANTE AVANT

Installation Steps

NOTE: Actual application may vary slightly from illustrations.

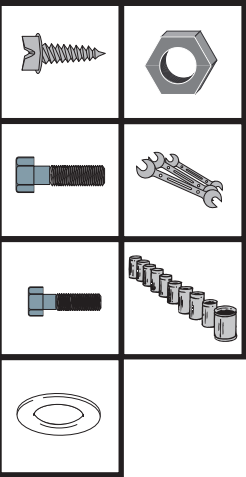

Note: Raise board and install #14 screws in all 1/8" drilled hole and hand tighten. If factory holes present install 8mm holes and finger tighten. Once all fasteners are installed tighten with tools noted.

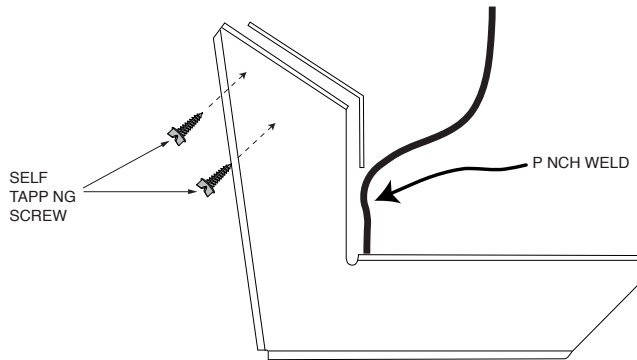

10

BACK

Care and Cleaning

- Wash only with mild soap & dry with a clean cloth.

Congratulations!

You have purchased one of many quality products offered by Lund ® branded products offered by Lund International, Inc. We take the utmost pride in our products and want you to enjoy years of satisfaction from your investment. We have made every effort to ensure that your product is top quality in terms of fit, durability, finish and ease of installation.

LUND®

