



Running Boards

For proper installation and best possible fit, please read all instructions BEFORE you begin.

Important Safety Information



- Please read this manual and follow its instructions carefully. To emphasize special information, the symbol  and the words WARNING, CAUTION and NOTE have special meanings. These special meanings apply except when laws or regulations require that the signal words be used with a different meaning.
- To be used with Lund Branded products only.
- Do not stand on Lund Running board and bracket while vehicle is in motion.
- Do not exceed 350 lbs. weight on the Lund EZ bracket system.
- Do not use the Lund EZ bracket system as a jacking point for vehicle.
- Do not use Lund EZ bracket system or running boards to fasten cargo.
- Periodically check all components for tightness.

Contents

NOTE: Actual product may vary from illustration.

Passenger Side Tube Step

A

Driver Side Tube Step

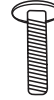
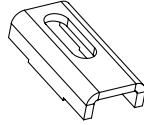
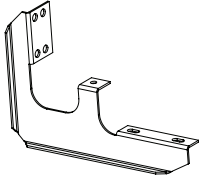
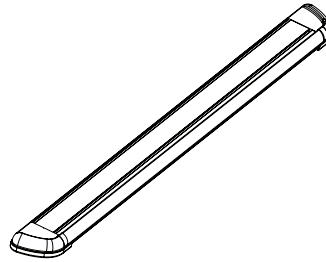
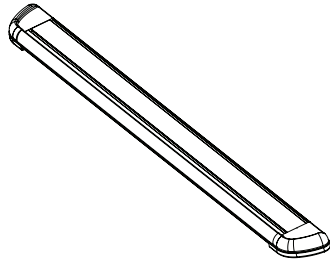

B

C

m-2761 bracket (4)

D

Head Carriage Bolt (4)



E

U-bolt (4)

F

5/16 Hex Flange Nut (12)

G

5/16" Hex Nut (8)

H

Flat Washer (8)

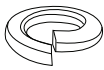

I

5/16" Lock Washer (8)

Tools Required

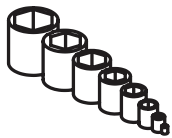

Socket Set (SAE & Metric)

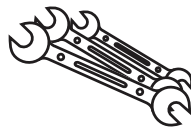

Wrench Set (SAE & Metric)

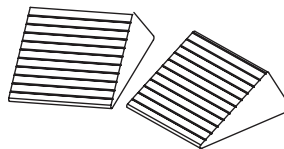

Wheel Chocks



Safety Glasses

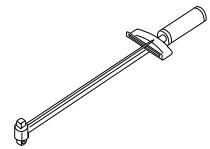

Torque Wrench

Preparation Before Installation

- Park your vehicle in a clean, level location. Check to make sure the vehicle is in park, or for manual drive models, place the transmission in first gear. Engage the parking brake.
- Chock one wheel on both sides with wheel chocks.
- Unpack the bracket kit and identify the parts according to the content descriptions above.

NOTE: Actual application may vary slightly from illustrations.

Installation Steps

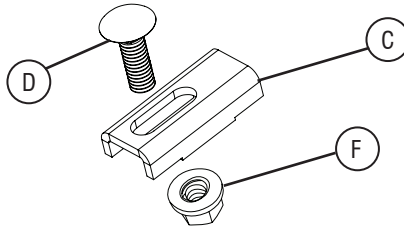

Assemble bracket with a carriage bolt (D) and flange nut (F). Do not thread the nut past the first three threads of the bolt. Repeat 4 times.

1

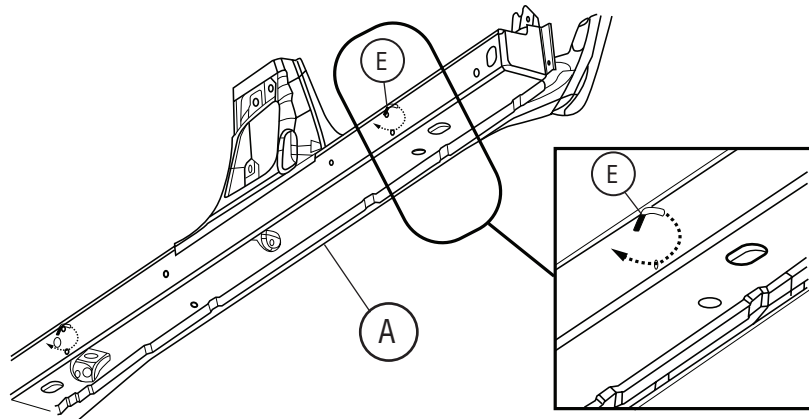

Starting on the driver's side inner rocker panel locate two sets of holes that are diagonal from each other. If the inner rocker panel is filled with sound deadening foam, pre-install the U-bolt (E) through the holes and foam with a twisting motion. Remove the U-bolt.

2

Installation Steps

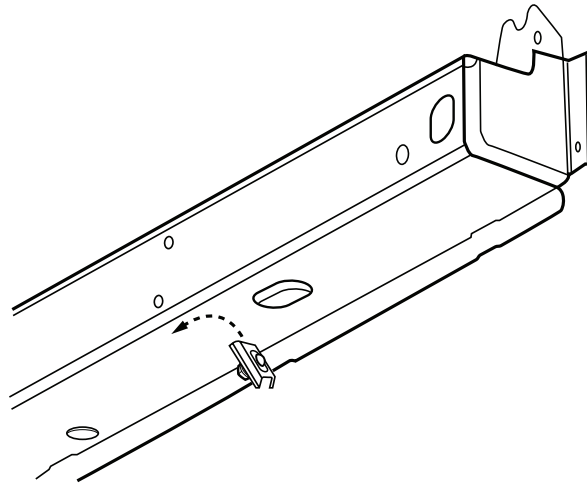

At the front set of diagonal holes, insert bracket from Step 1 into the large hole and into the inner rocker panel. If sound deadening foam is present, press foam to the side providing clearance for bracket. Move the bracket back and forth to make sure it is sitting flat.

3

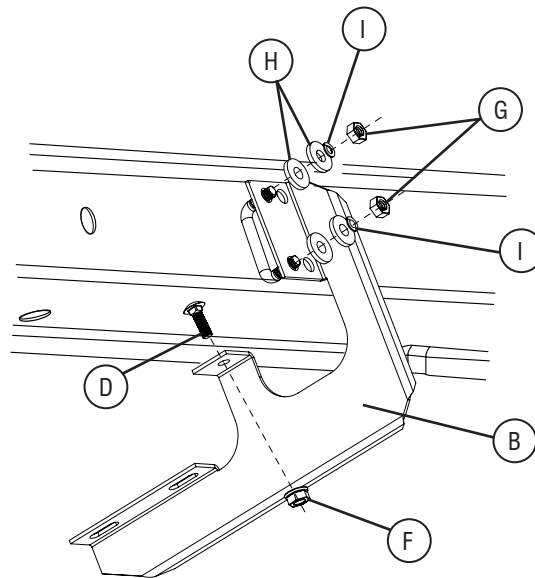

Position bracket over the installed U-bolts, being careful to prevent the U-bolt from slipping into the rocker panel. Slide the bolt of bracket into the upper notch of bracket. (Make sure that the bolt is fully engaged in the slot.) Install remaining fastener and finger tighten nut.

4

Installation Steps

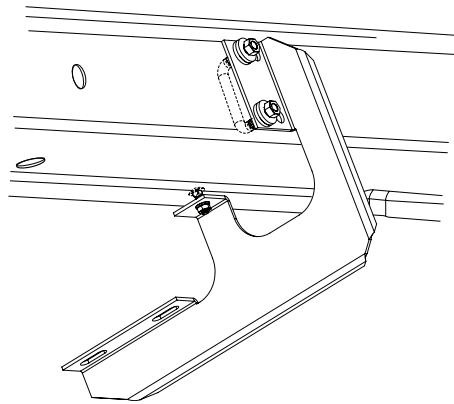
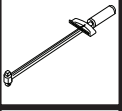

Thread a nut on both ends of the U-bolt. Tighten to 18 ft. lbs. torque.

5

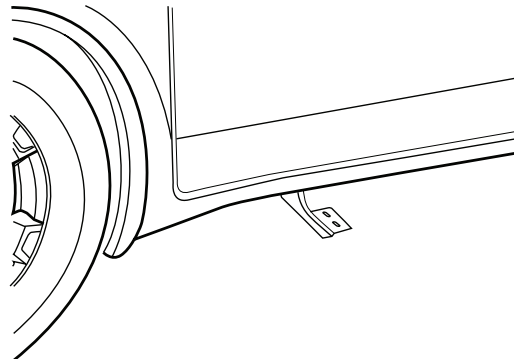

Repeat Steps 1 and 5 for the rear mounting bracket. Do not pinch emergency cables.

6

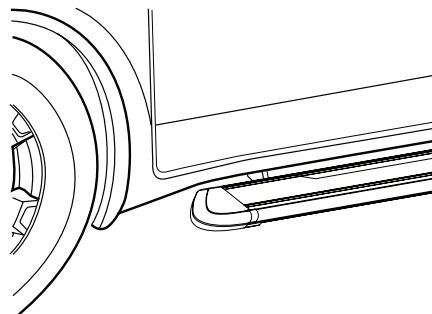

Position the driver's side tube step onto bracket and center on vehicle. Push into rocker panel as far as possible. Install (1) serr flange nut and bolt. Torque fasteners to 18 ft. lbs. Repeat at opposite end of board. Repeat Steps 1 thru 8 for opposite side of vehicle.

7

Inspection After Installation

- Inspect all bolt and nuts for proper tightness.

Care and Cleaning

- Wash only with mild soap & dry with a clean cloth.
- Avoid the use of automatic “brush-syle” car washes.
- Every 3 months or 5000 miles check the cover tension and all components for tightness.

Congratulations!

You have purchased one of the many quality Deflecta-Shield® branded products offered by Lund International, Inc. We take the utmost pride in our products and want you to enjoy years of satisfaction from your investment. We have made every effort to ensure that your product is top quality in terms of fit, durability, finish and ease of installation.

LUND®

