

Installation Instructions

I - Sheet Number LUNDRB58 Rev.A



Running Board Bracket Kit 2015-16 Ram 1500/2500/3500

For proper installation and best possible fit, please read all instructions BEFORE you begin.

Important Safety Information



- To be used with Lund® branded products only.
- Do not stand on Lund running board or bracket while vehicle is in motion.
- Do not use the brackets as a jacking point for the vehicle.
- Do not use the bracket system or running boards to fasten cargo.
- Periodically check all components for tightness.
- Be sure to wear safety glasses while installing brackets.
- When using power tools, read and understand all operating instructions.

Contents

NOTE: Actual product may vary from illustration.



Driver Side Front Bracket x1



Driver Side Mid Bracket x1



Driver Side Rear Bracket x1



Bolt Plate x6



Plastic Insert (long) x6



Plastic Insert (short) x6



Passenger Side Front Bracket x1



Passenger Side Mid Bracket x1



Passenger Side Rear Bracket x1



Nuts x12



Washers x18



Bolts x12

Tools Required

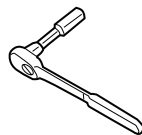

Ratchet and Extension



Socket Set

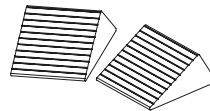

Wheel Chocks



Safety Glasses

Preparation Before Installation

- Park your vehicle in a clean, level location. Check to make sure the vehicle is in park, or for manual drive models, place the transmission in first gear. Engage the parking brake. Chock wheels.
- Unpack the bracket kit and identify the parts according to the content descriptions.
- Air tools recommended.

Installation Steps

NOTE: Actual application may vary slightly from illustrations.

Identify the (3) mounting locations for each bracket by looking under the driver side of the vehicle at the rocker panel and pinch welds. NOTE: Check to see if the **Middle** and **Rear** locations have threaded or open holes.

Driver side shown

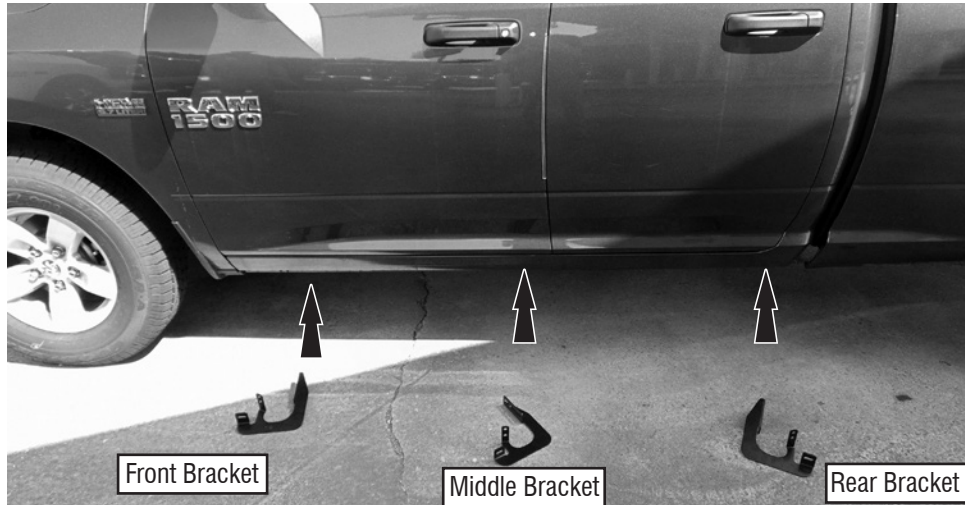

Fig. 1

1



Align the Front Bracket with hole in rocker panel and the (2) holes in the pinch weld. Install (1) bolt with (1) washer in upper bracket hole in rocker panel. NOTE: Do **NOT** fully tighten at this time.

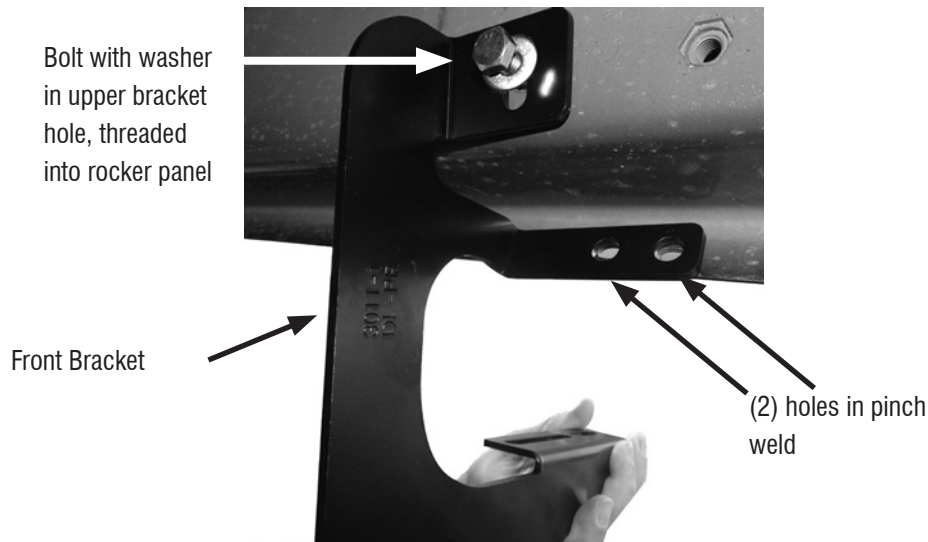

Fig. 2

2



Install (2) bolts with (2) washers in the pinch weld from the **OUTSIDE**, and secure with (2) nuts. NOTE: Do **NOT** fully tighten at this time.

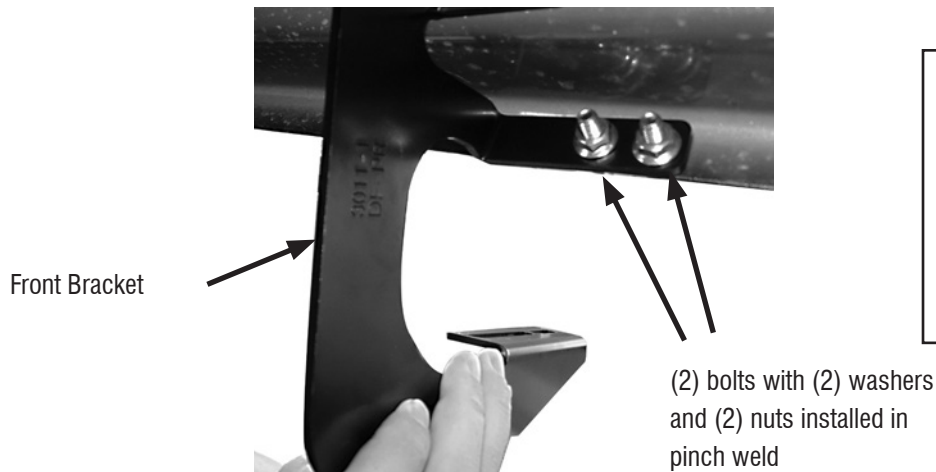
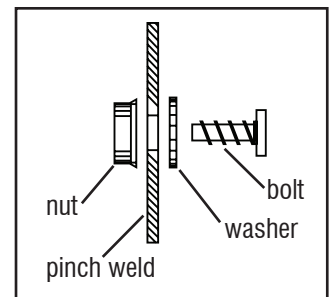

Fig. 3



3

Installation Steps

NOTE: Actual application may vary slightly from illustrations.

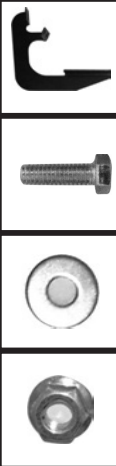

If the Middle Bracket mounting location has an **OPEN HOLE** (no threads) in the rocker panel: **Skip to Step 6**
 If the Middle Bracket mounting location has a **THREADED HOLE** in the rocker panel: Repeat **Steps 2-3**.
NOTE: Do NOT fully tighten at this time.

Bolt with washer
 in upper bracket
 hole (threaded),
 into rocker panel

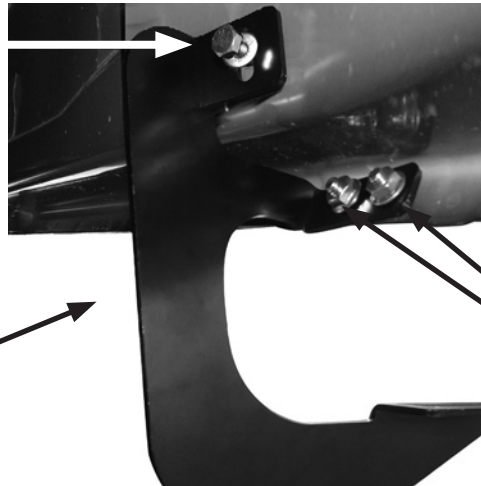

Middle Bracket

(2) bolts with (2) washers
 and (2) nuts installed in
 pinch weld

4

Fig. 4

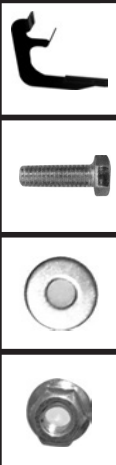

If the Rear Bracket mounting location has a threaded hole in the rocker panel, repeat **Steps 2-3**. **NOTE: Do NOT fully tighten at this time. Skip to Step 12.**

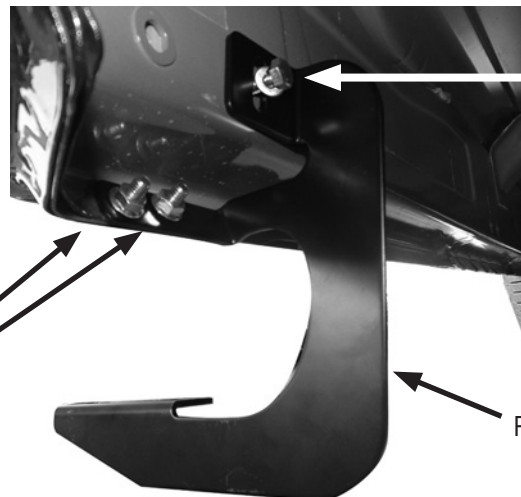

Bolt with washer
 in upper bracket
 hole (threaded),
 into rocker panel

(2) bolts with (2) washers
 and (2) nuts installed in
 pinch weld

Rear Bracket

5

Fig. 5

If the **Middle** and **Rear** mounting locations have **open holes** (not threaded), remove tape to expose another hole above the rocker panel mounting holes.

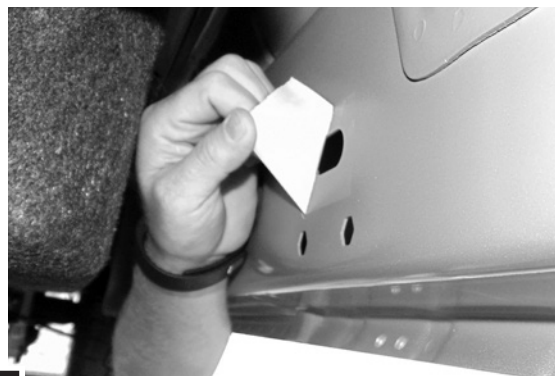
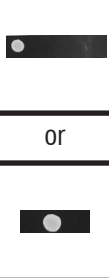

Fig. 6

6



Bend (1) Plastic Insert 90°, a half an inch from the end as shown.



Fig. 7

NOTE: The small or large plastic inserts are used to keep the bolt plate from falling inside the rocker. The installer should choose the plastic insert that is most suitable for the particular vehicle (all of the kits will come with both small and large plastic inserts).

7

Installation Steps

NOTE: Actual application may vary slightly from illustrations.



Install Plastic Insert on Bolt Plate as shown.

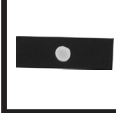

Carefully use the Plastic Insert to install the Bolt Plate through the rocker panel mounting hole as shown.
NOTE: Use extra caution not to drop the Plastic Insert and Bolt Plate inside the rocker panel.



Fig.8



Fig.9

8

9



Align the Middle Bracket with Bolt Plate stud. Secure the Middle Bracket to the Bolt Plate using (1) Nut.
NOTE: Do **NOT** fully tighten at this time.



Nut used to secure Middle Bracket to Bolt Plate in rocker panel



Middle Bracket

Fig.10

10



Install (2) bolts with (2) washers in the pinch weld from the **OUTSIDE**, and secure with (2) Nuts. NOTE: Do **NOT** fully tighten at this time.



Middle Bracket

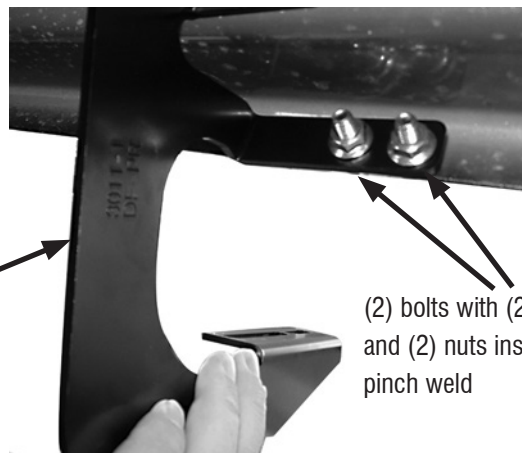

(2) bolts with (2) washers and (2) nuts installed in pinch weld

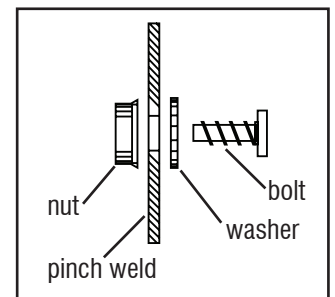

11

Fig.11

Repeat **Steps 6 -11** for the Rear Bracket.

Installation Steps

NOTE: Actual application may vary slightly from illustrations.

- Repeat installation steps for Passenger Side of vehicle.
- Install running boards as per the separate running board instruction sheet.
- After running boards have been secured to brackets, go back and fully tighten all brackets to the vehicle.

12

Inspection After Installation

- Inspect all bolts and nuts for proper tightness.

Care and Cleaning

- Wash only with mild soap & dry with a clean cloth.
- Do not use cleaning solvents of any kind.

Congratulations!

You have purchased one of the many quality Lund[®] branded products offered by Lund International, Inc. We take the utmost pride in our products and want you to enjoy years of satisfaction from your investment. We have made every effort to ensure that your product is top quality in terms of fit, durability, finish and ease of installation.

LUND[®]

