

Installation Instructions

I - Sheet Number LUNDRB04 Rev.B

LUND Running Boards

For proper installation and best possible fit, please read all instructions **BEFORE** you begin.

Important Safety Information



- CAUTION - Before driving, ensure that the Running Boards are properly anchored to vehicle.
- Do not use automatic "brush-style" car washes.
- Do not use cleaning solvents of any kind.
- Periodically check all components for tightness.

Contents **NOTE:** Actual product may vary from illustration.

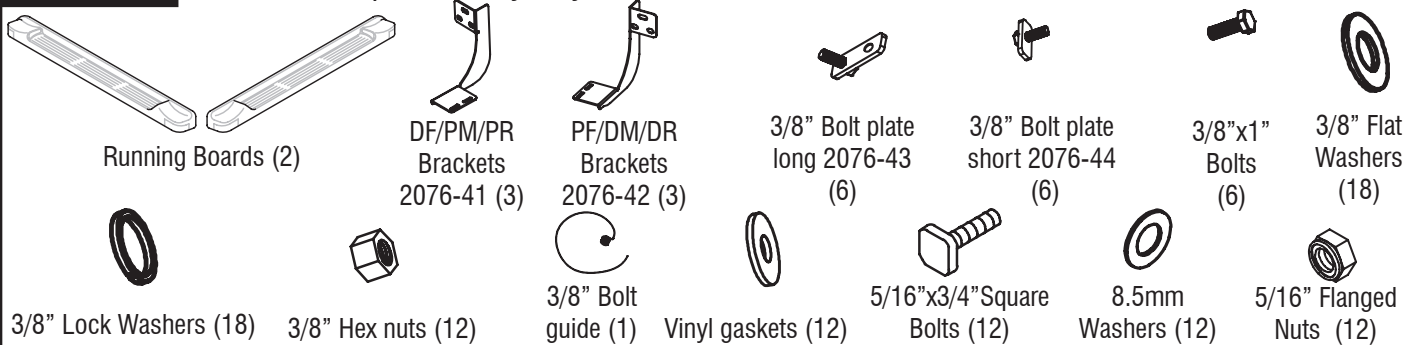

Tools Required

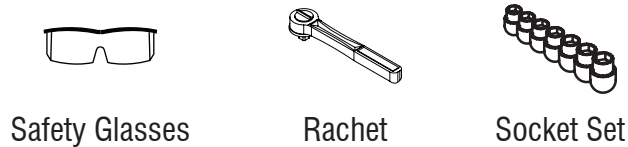

Preparation Before Painting/Installation

- A trial fit is recommended to ensure proper positioning and fit.
- Check fit of parts before painting as we will not accept the return of modified or painted parts.

Installation Steps **NOTE:** Actual application may vary slightly from illustrations.

	Screw Bolt guide to Bolt plate short 2076-44, and feed through large upper hole and pull through lower right hole. Install Vinyl washer over bolt before removing Screw bolt guide.		Screw Bolt guide to Bolt plate long 2076-43, and feed through large upper hole and pull through lower left hole. Install Vinyl washer over bolt before removing Screw bolt guide.
1		2	

Installation Steps

NOTE: Actual application may vary slightly from drawings.



Attach mounting bracket over two studs and twist left stud so that hole in bracket lines up with upper hole.

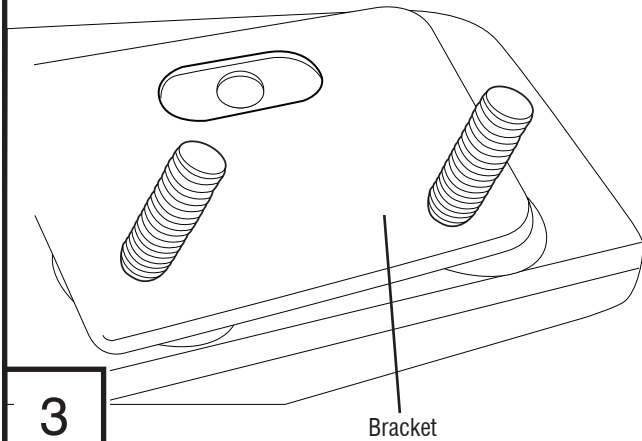

3



Install bolt with lock washer and washer in top hole. Install washer, lock washer, and hex nut on studs. Repeat **Steps 1 thru 4** for remaining brackets.

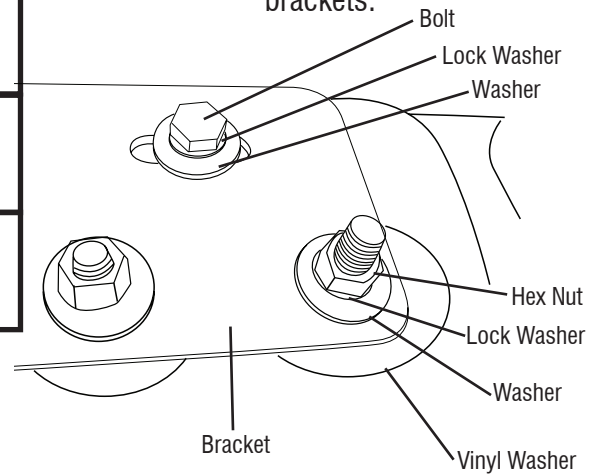

4

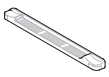

Install square bolts into the shaded outer channels. Three (3) per channel to attach boards to brackets.

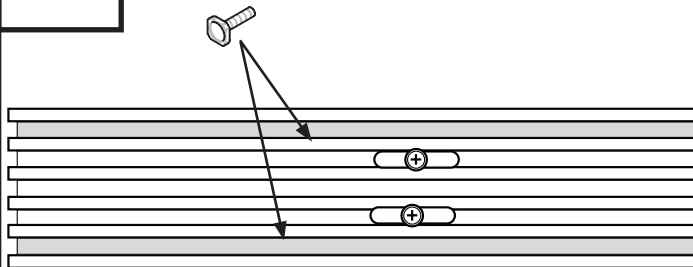

5



Attach boards to brackets.



8.5mm Washer
Lock Washer
5/16 Flanged Nut

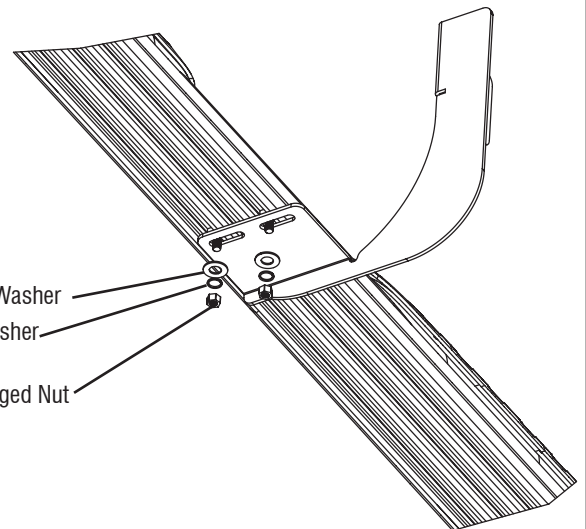

6

Care and Cleaning

- Wash only with mild soap & dry with a clean cloth.

Congratulations!

You have purchased one of the many quality Lund[®] branded products offered by Lund International, Inc. We take the utmost pride in our products and want you to enjoy years of satisfaction from your investment. We have made every effort to ensure that your product is top quality in terms of fit, durability, finish and ease of installation.

LUND[®]

