

# Installation Instructions



## Elite Series Fender Flares

### Important Safety Information



- CAUTION - Before driving, ensure that the fender flare is properly secured to vehicle.
- Do not use automatic "brush-style" car washes.
- Do not use cleaning solvents of any kind.
- Periodically check all components for tightness.

### Contents

**NOTE:** (Content shown below is for (4) piece installations. (2) Piece installations will contain smaller quantities.)

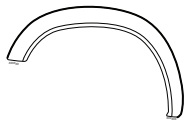

Driver side front

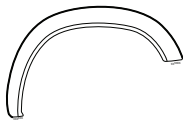

Passenger side front



U-Clip x6

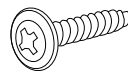

Screw x6



Black Mylar Tab  
x6



**(RX Style only)**  
Rivet + Nylon Nut  
x32

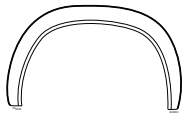

Driver side rear

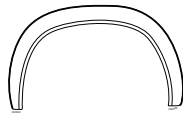

Passenger side rear



Rubber Seal

### Tools Required

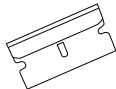

Razor Blade



Hex Key 4.0 and 4.5



Socket Wrench w/  
8mm Socket

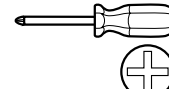

Phillips screwdriver

### Preparation Before Painting / Installation

#### Custom Paint Job (Optional)

Please test fit all the flares first to ensure you have the correct flares for your vehicle. We are not responsible for any costs you may incur if you did not confirm the flares before having it painted. We recommend hiring professionals to custom paint the products. It is also ideal to have the painting done prior to the installation to eliminate any over-spraying issues.

#### Remove existing fender flares. (Skip this step if you don't have existing fender flares.)

Remove all the screws and fasteners currently holding the existing flare to the vehicle. Write down and save all the screws you have removed for re-use with the Lund fender flares. If certain areas of the existing flares are held on with double sided tape, you will have to pry your existing flare off. Please do so carefully to avoid damage to your vehicle body.

#### Test fitting.

Hold each and every flare up to the fender. Make sure you align the flare to the contour of the body, and the mounting holes lineup to the existing mounting holes on the inner fender lip (if applicable). Don't worry if not all the holes line up, as some holes are meant to be used with different installation hardware that is provided. The flares may not be sitting flush at this time, our flares are designed to flex into the bodyline when you actually install them using the provided and existing hardware. At any time, do not drill or modify the fender flare in anyway, as you will void your warranty.

#### Remove other existing parts.

Some vehicles may require the removal of existing parts that will interfere with the installation. Common item would be mud flaps; however by using fender flares, they act as another form of mud deflector. If you are not confident in doing so, this will be a good time to take your vehicle to a professional for the installation. Save existing screws and fasteners from the vehicle.

#### Cleaning the vehicle.

Make sure to wash your vehicle, especially the area the fender flares will be mounted to including the inner fender lip. Any dirt or debris that has not been cleaned or removed can potentially cause the improper fitment of the fender flare. If you are covering existing rust, we recommend sanding down the rust and primer over to prevent further deterioration of the metal in the fender. Make sure the vehicle is dry before the installation. The fender flares come ready to be installed, however if you need to clean them, please use a mild detergent to wash and then dry completely.

# Preparation Before Painting / Installation

## For RX Style Only (SKIP if you have SX or EX style)

Install the rivet screws and nuts to each of the rivet holes on the flare. Our rivets are designed to screw on to the fender flares only, and they shouldn't be touching the vehicle body at all. Using hand tools, tighten nuts until fastener is snug. **DO NOT OVERTIGHTEN** as this may damage the fender flare.

## Installation of the Rubber Seal

Before you start cutting any rubber seal, please study the diagram. Do not use the rubber seal in any other areas other than indicated; otherwise you will end up with a shortage of rubber seal on your last flare. Start the installation of the rubber seal as indicated in the diagram. Then cut the rubber seal with a razor. Follow the same instruction for the remaining flares.

\*Each roll of the rubber seal provided is long enough to complete the 4 fender flares and with extra to spare, however we are not responsible for the improper use of the rubber seal. Contact Lund International to purchase additional rolls of rubber seal.

## Installation Steps **NOTE:** Actual application may vary slightly from illustrations.

### Front Flare

1. Locate the factory installed mud flap on the passenger side front wheel well.
2. Remove (2) factory installed screws and (1) factory installed fastener. Remove mudflap from vehicle.
3. Reinstall the previously removed lower factory installed screw as indicated above. Keep remaining screw. Fastener can be discarded.
4. Remove and keep (8) factory installed screws. The remaining screws will be re-used to install the front flare.
5. Hold flare to vehicle and start re-installing the remaining (9) factory screws with an 8mm socket. Do not tighten
6. Press flare firmly against sheet metal and tighten all screws.
7. This completes front flare installation.

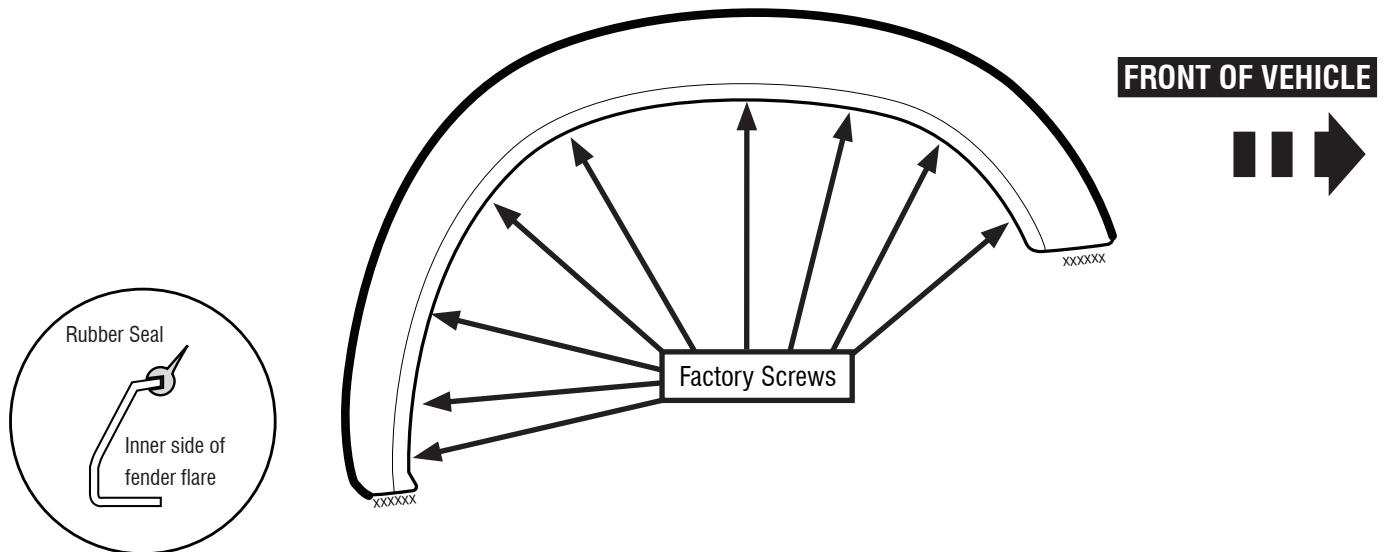

**Rear Flare**

8. Locate the (2) factory installed mudflaps on the passenger side rear wheel well.
9. Remove and keep (2) factory installed screws, and remove mud flap from vehicle. These factory screws will be used to install the rear fender flare.
10. Remove and keep (1) factory installed screw and remove mud flap from vehicle. The factory screw will be used to install the rear fender flare.

**Trucks equipped with fender liners go to Step 16.**

**Trucks equipped with fender liners will have (3) factory screws at the top of the fender.**

**Trucks without this type of fender liner continue to step 11.**

11. Remove (4) factory installed screws using an 8mm socket wrench. Keep screws for installation of the rear flare.  
NOTE: there will be (3) existing factory holes that are empty along the top portion of the wheel well.
12. Install supplied Black Mylar Tab over existing empty factory holes. (See U-Clip Installation detail below.)
13. Install supplied U-Clip over tab.
14. Using an awl or similar tool, poke a hole through Black Mylar Tab using the U-Clip hole as a guide. Repeat Steps 12-14 for remaining (2) empty holes.
15. Hold flare in place and start screw using a Phillips screwdriver in the same (3) locations.
16. Remove and keep (7) factory installed screws.
17. Hold flare in place and reinstall (3) factory screws removed in Step 16. Do not tighten.
18. Continue holding flare in place while you start reinstalling (7) factory screws using an 8mm socket wrench. Do not tighten.
19. Press flare firmly against sheet metal and tighten all screws.
20. This completes rear flare installation.

**FRONT OF VEHICLE**

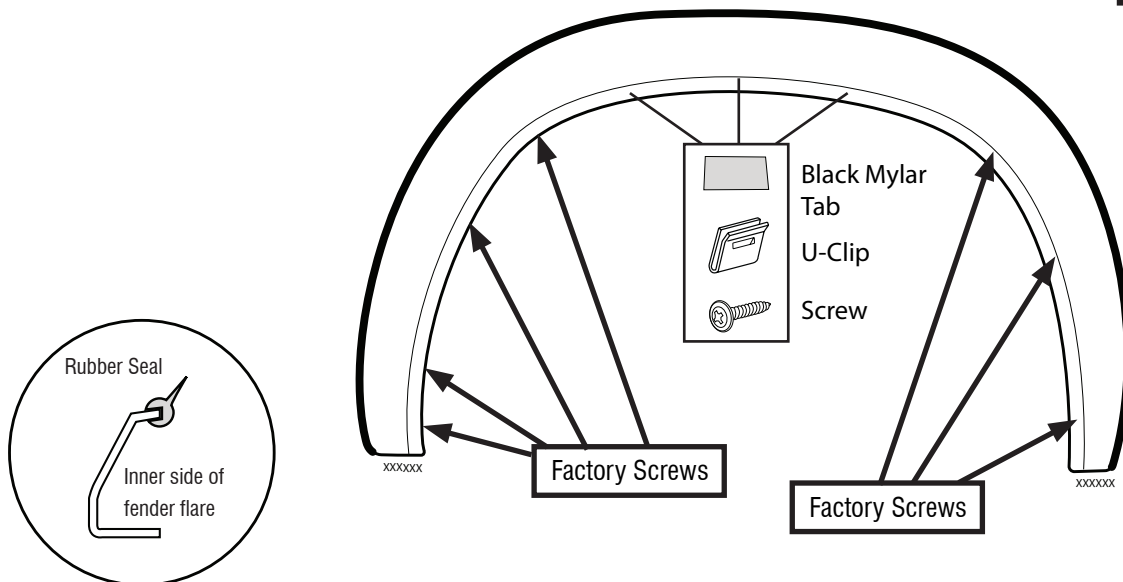

**—————** Use Rubber Seal here  
**xxxxxxx** Do NOT use Rubber Seal here

## Installation Steps U-Clip Installation

**NOTE:** Actual application may vary slightly from illustrations.

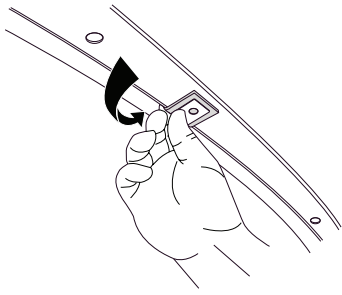

1

Wrap Black Mylar Tab over hole, then install U-Clip on top of it.

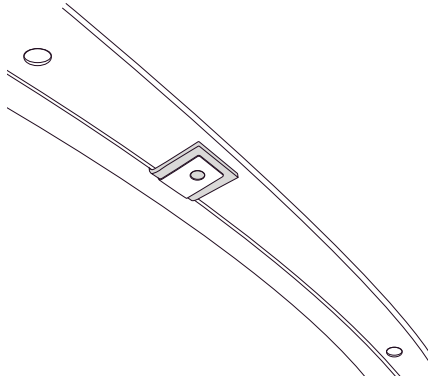

2

U-Clip and Black Mylar Tab properly positioned.

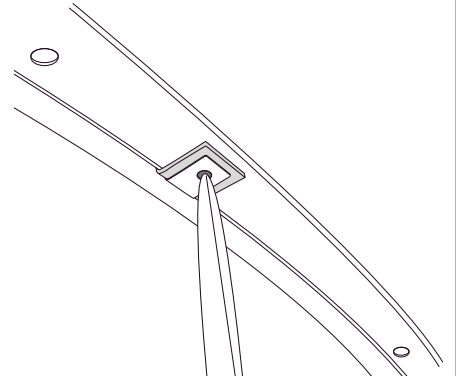

3

Poke hole in Black Mylar Tab.

## Rivet Style Only

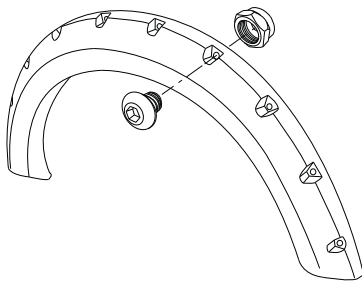

For Rivet Style Only

## Care and Cleaning

- Lund fender flares are built to last; any detergent you use to wash your vehicle is sufficient to clean the flares. Do not use any harsh abrasive detergents.

PLEASE READ: dirt and debris can become lodged between the fender flares and the vehicle's fenders, causing scratching and paint wear from vibration. Lund International is not responsible for any damage, and the installation of our fender flares is done with the buyer's understanding that this scratching and paint wear may occur.

## Congratulations!

You have purchased one of the many quality Lund<sup>®</sup> branded products offered by Lund International. We take the utmost pride in our products and want you to enjoy years of satisfaction from your investment. We have made every effort to ensure that your product is top quality in terms of fit, durability, finish and ease of installation.



The material that your product is made from can be recycled. Please also consider recycling the packaging that your product came in.



# LUND<sup>®</sup>

LUND<sup>®</sup>  
INTERNATIONAL