

PARTS LIST:

1	Bull Bar	4	12-1.75mm Nylon Lock Nuts
1	Driver Side Frame Mounting Bracket	4	Bolt Assembly
1	Passenger Side Frame Mounting Bracket	1	Wire Harness
2	Bull Bar Mounting Brackets (left or right)		
1	LED Light Bar		
4	12-1.75mm x 30mm Hex Bolts		
8	12mm x 32mm OD x 3mm Flat Washers		

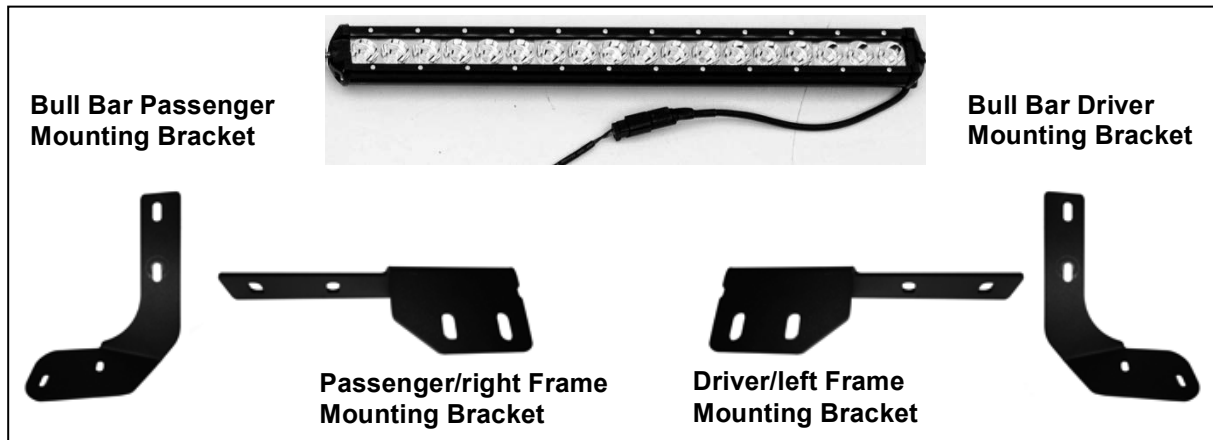

EQUIPMENT NEEDED:

- Safety Glasses
- Ratchet Set
- Pliers or Adjustable Wrench

IMPORTANT NOTES:

- Bull Bar *may* interfere with parking sensors on the bumper.
- The LED light bar can be wired into the factory lighting.
- If state law requires a front license plate, a relocation kit is available separately.
- For cleaning, mild soap may be used to clean the Bull Bar, and aluminum polish may be used on the stainless steel to polish small scratches and scuffs on the finish.
- REMOVE CONTENTS FROM BOX, VERIFY ALL PARTS ARE PRESENT, & READ INSTRUCTIONS CAREFULLY. **NOTE: PROFESSIONAL INSTALLATION IS RECOMMENDED.**

LIGHT BAR INSTALLATION:

1. Remove light bar from box and screw bolts and washers into each end.
2. Slide bolts into crossbeam brackets with the washers on the outside of the bracket, and tighten using the supplied allen key.



BULL BAR INSTALLATION:

1. Start installation at the driver side, front of the vehicle. Remove the driver side tow hook, **(Figure 1)**.

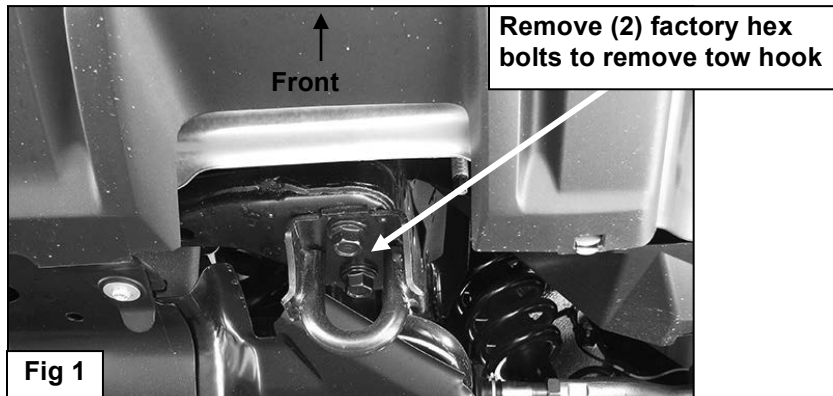

2. Select the driver side Frame Bracket, **(Figure 2)**. Check the fit between the tow hook and the Bracket for reinstallation over the Bracket. **NOTE:** Some factory tow hooks may not clear the Bracket and cannot be reinstalled. Check for fit before bolting tow hook and Bracket in place.



(Fig 2) Driver/left Frame Mounting Bracket

3. Bolt the Bracket to the underside of the frame channel reusing the factory tow hook bolts, either with or without the tow hook, (**Figure 3**). Do not fully tighten hardware at this time.

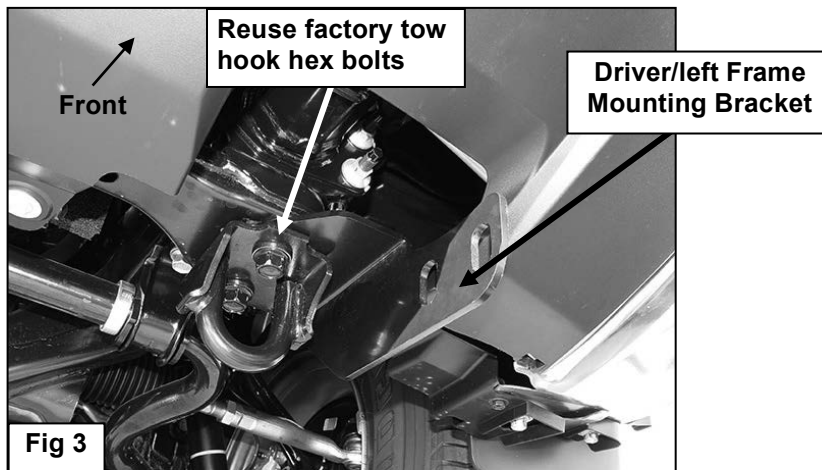

4. Repeat **Steps 2—4** for passenger side Frame Mounting Bracket installation.
5. Carefully unwrap the Bull Bar. Select (1) Bull Bar Mounting Bracket. Bolt the Bracket to the Bull Bar with (2) Bolt Assembly's, (**Figure 4**). Leave hardware loose at this time.

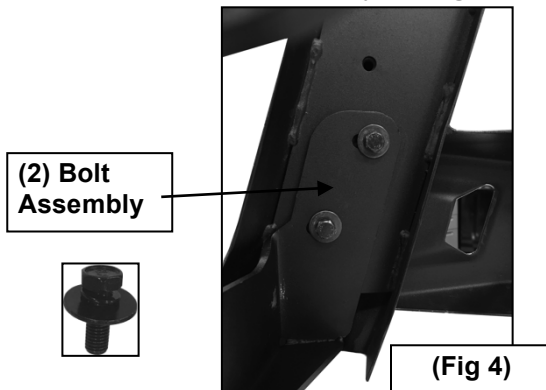

6. Repeat **Step 6** to install the passenger side Mounting Bracket.

7. With assistance, line up the Mounting Brackets on the Bull Bar with the outside of the Frame Brackets. Bolt the Bull Bar to the Frame Brackets with the included (4) 12mm x 30mm Hex Bolts, (8) 12mm Flat Washers and (4) 12mm Nylon Lock Nuts, **(Figure 5)**. Do not tighten hardware at this time.

(2) 12mm x 30mm Hex Bolts
(4) 12mm Flat Washers
(2) 12mm Nylon Lock Nuts

Driver Side Installation Pictured

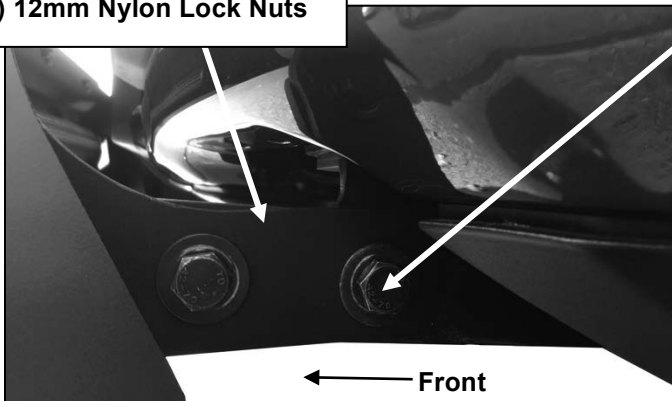

(Fig 5) Attach both Mounting Brackets to the Bull Bar first, then attach the Bull Bar and Brackets to the Frame Brackets

8. Level and adjust the Bull Bar properly and tighten all hardware.
9. Perform periodic inspections to verify that all hardware is secure and tight.