

Installation Instructions

LUND®

Ramp Kit

For proper installation and best possible fit, please read all instructions BEFORE you begin.

Important Safety Information

- ***TO AVOID RISK OF SERIOUS INJURY OR PROPERTY DAMAGE READ AND UNDERSTAND ALL WARNINGS AND INSTRUCTIONS BEFORE USING RAMPS.***
- ***RAMP ENDS EXCEED THE STRENGTH OF YOUR PLANK. EXERCISE EXTREME CAUTION.***
- ***PLANK MAY NEED REINFORCEMENT.***

CAUTION

- Do not exceed the lesser of: (1) loading surface of vehicles manufacture's weight rating; or (2) a maximum distributed load capacity of 700 pounds per pair of ramps.
Do not park load on the ramps.
- Ramp end or plank may break or slide causing serious injury if misused or not properly secured. Make sure each ramp end is secured to the loading surface of vehicle.
- Planks should be built using (knot free) Douglas Fir 2" x 10" (1 1/2" x 9 1/2") to achieve the maximum distributed load capacity of 700 pounds per pair of ramps. For additional strength, oak planks are recommended. User is responsible for verifying the condition and strength of material used for the planks, which limits maximum ramp and plank load capacity. Douglas Fir 2" x 8" (1 1/2" x 7 1/2") can be used yielding a lighter capacity.
- Ramps must be clean, dry, and free of grease, mud, and other materials prior to use. Planks should receive no-skid coating or adhesive. Non-skid coating or adhesive for planks may be purchased at your local marine or hardware stores.
- Plank must be temporarily secured with the ramp ends to the tailgate, or loading surface of vehicle while loading or unloading.
- The ramp ends or planks are not intended for loading automobiles, trucks, and persons or as handicap access.
- Do not ride equipment on ramp ends or planks. Stand to side when loading, use winch if necessary and keep body clear in case load or ramp ends or planks shifts or break.
- When loading or unloading from a vehicle, make sure emergency brake is on, vehicle is in gear (engine off) with wheels blocked.
- Do not park equipment on ramp ends or planks or use as jack for changing oil, tire, or vehicle maintenance.
- Do not alter ramp ends or use another ramp other than as instructed in these cautions and accompanying instructions.
- Do not leave ramp ends or planks unattended when attached.
- Store properly when not in use.
- Read and understand all tool safety instructions before using tools.

Contents

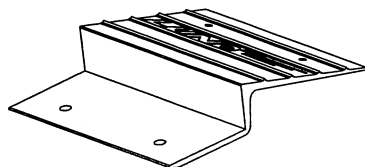

EXTRUDED RAMP END
2X

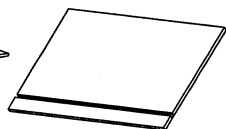

PAD
2X



SERRATED FLANGE NUT
4X



STEEL PIN
4X



CARRIAGE BOLT
4X

Wood Plank not provided in kit

Tools Required



3/16" DRILL BIT

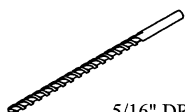

5/16" DRILL BIT

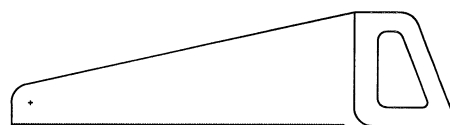

SAW

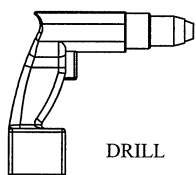

DRILL

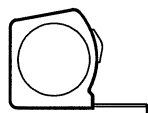

TAPE MEASURE



SAFTY GLASSES

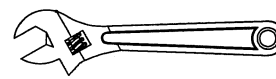

ADJUSTABLE WRENCH

Assembly Steps

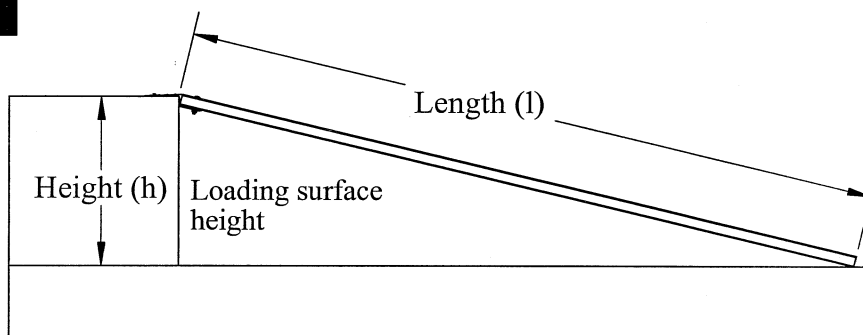

Figure A

1

Figure A	height (h)	length (l)
	1'-0"	3'-4"
	1'-2"	3'-11"
Recommended Range	1'-4"	4'-5"
	1'-6"	5'
	1'-8"	5'-6"
	1'-10"	5'-6"
	2'-0"	6'-7"
	2'-2"	7'-2"
Planks in this range may need additional support	2'-4"	7'-8"
	2'-6"	8'-4"
	2'-8"	8'-11"
	2'-10"	9'-5"
	3'-0"	10'

Warning

Ramp surfaces higher than 3 feet are considered dangerous due to the length of plank required. Do not attempt without additional support to the ramp.

2

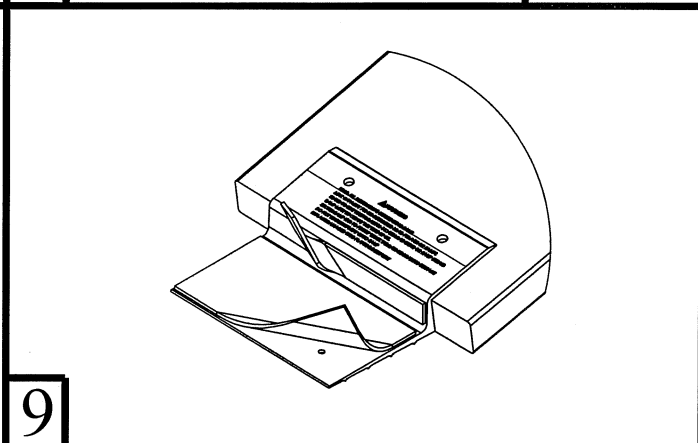
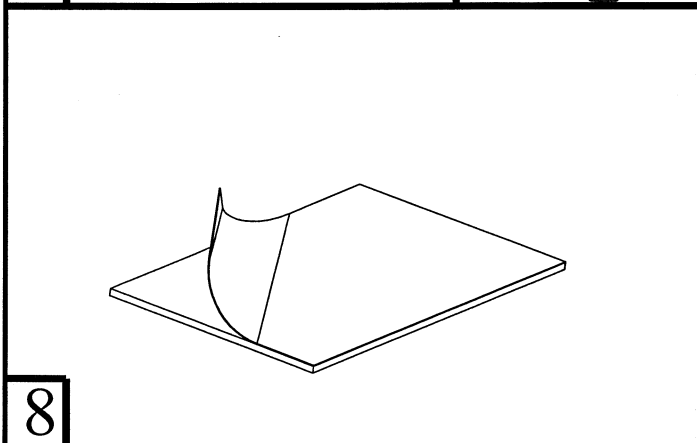
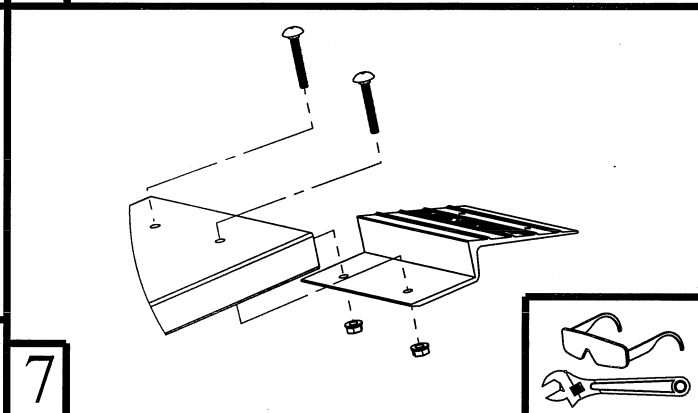
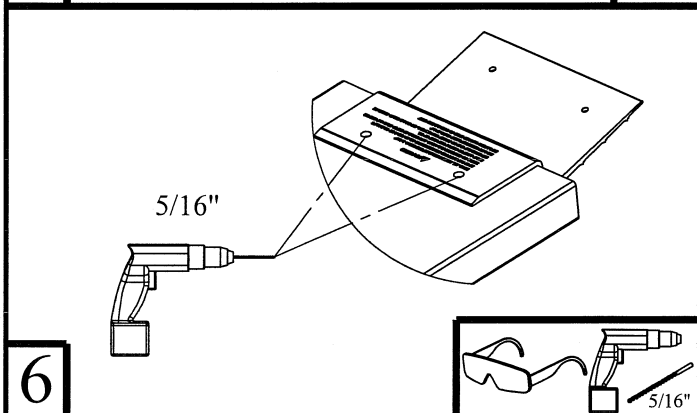
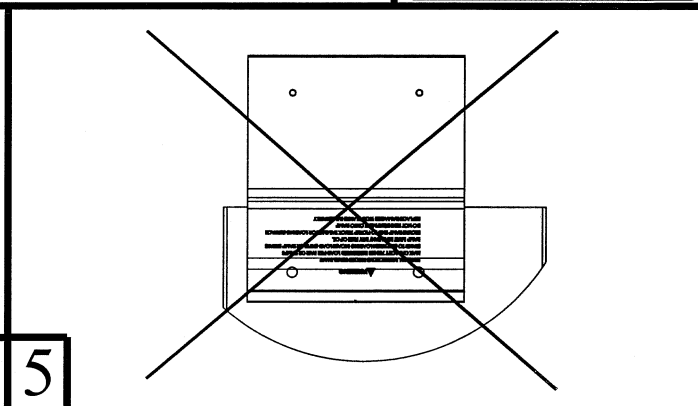
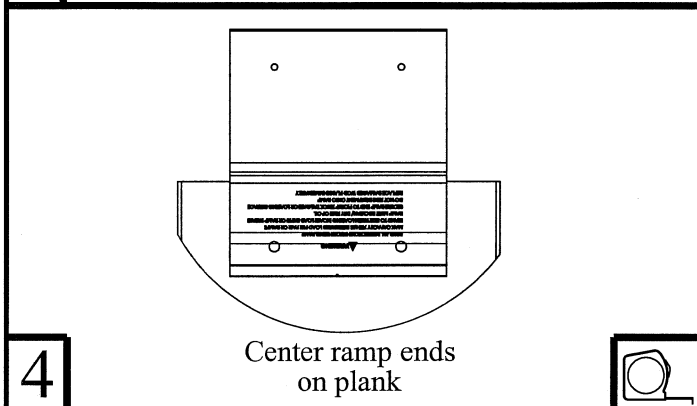
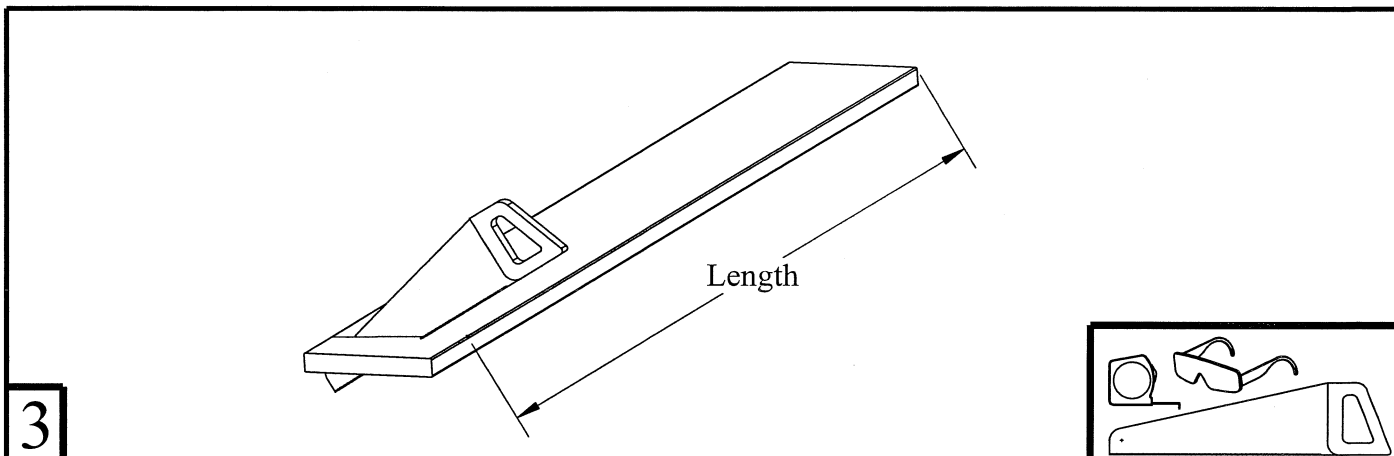

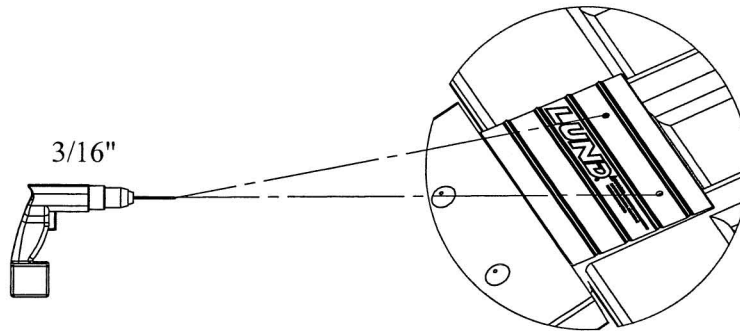
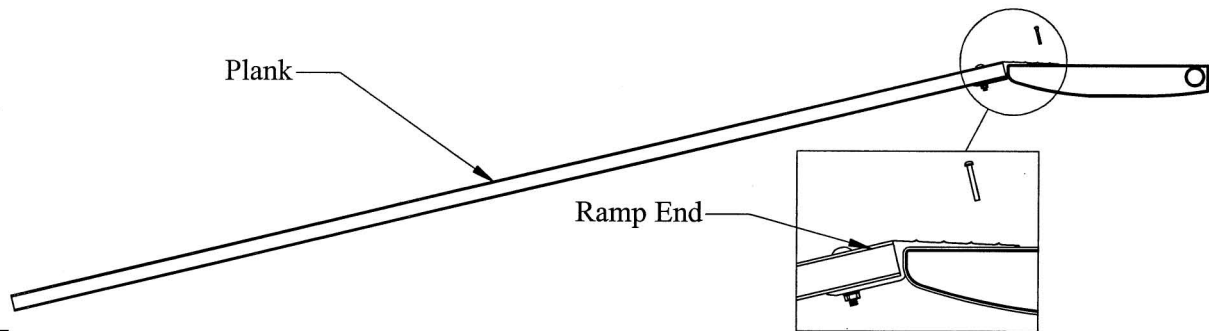
Installation Steps**10****11****Congratulations**

You have purchased one of the many quality Lund® branded products offered by Lund International, Inc. We take the utmost pride in our products and want you to enjoy years of satisfaction from your investment. We have made every effort to ensure that your product is top quality in terms of fit, durability, finish and ease of installation.

