

# Installation Instructions

# LUND®

## Hitch Rack™

For proper installation and best possible fit, please read all instructions BEFORE you begin.

### Important Safety Information



- CAUTION - Check local and state laws before using Hitch Rack.
- Do not use Hitch Rack if damaged.
- Do not use Hitch Rack if any parts are missing.
- Use only during daylight hours.
- Use only with Class IV or higher hitches.
- Do not exceed cargo load rating of your vehicle.
- Do not exceed rating of your receiver.
- Do not cut, drill, weld, or modify Hitch Rack.
- Attach safety flag to end of load.
- Install all pins.
- Do not use Hitch Rack when vehicle is not loaded.
- Do not use Hitch Rack with loads extending more than 6 feet beyond the back edge of dropped tailgate (Truck mode) and no more than 3 feet beyond Hitch Rack T Bar (SUV mode).
- Set elevation of T Bar to match the level of the truck bed. (Match roof level in SUV mode.)
- Loads must be placed against the front of the truck bed.
- Center the load in the middle of the truck bed in the middle of the Hitch Rack.
- Tie the load (lumber, etc.) down so that it will not bounce or slide in any direction.

### Contents **NOTE:** Actual product may vary from illustration.

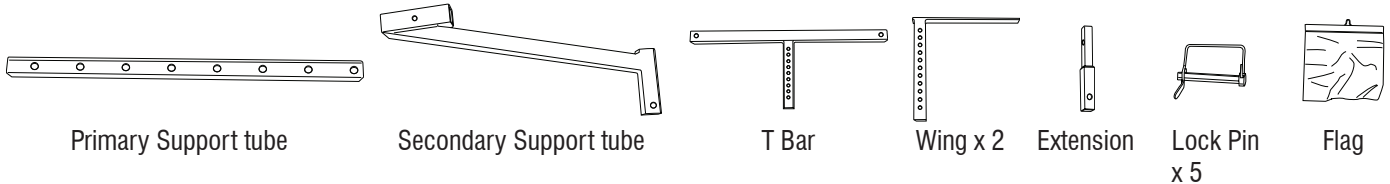

### Installation Steps **NOTE:** Actual application may vary slightly from illustrations.

#### Truck Install **Proceed to step 7 for SUV install.**

Insert primary support tube into receiver. Insert hitch pin. (Hitch pin not supplied).

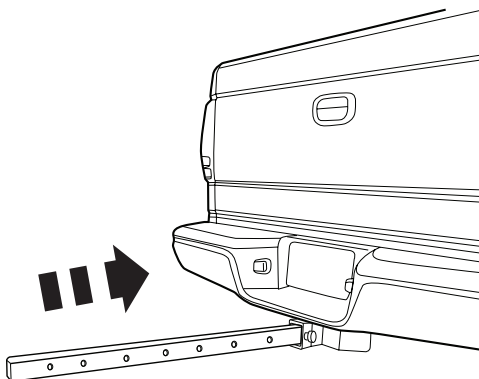

1

Insert secondary support tube over primary support tube and install lock pin.

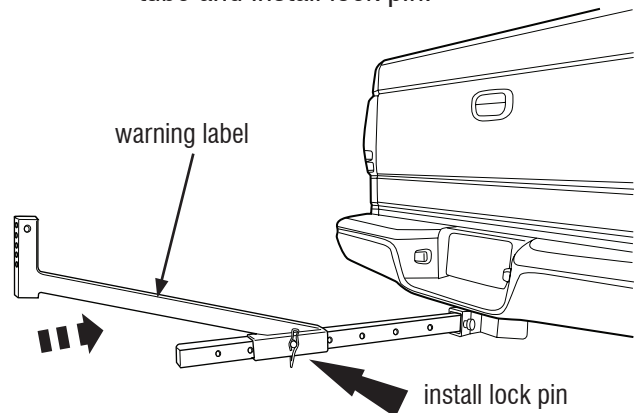

2

**NOTE:** Do not remove warning label

## Installation Steps

**NOTE:** Actual application may vary slightly from drawings.

Install T bar into secondary support tube.  
Secure in place with lock pin.

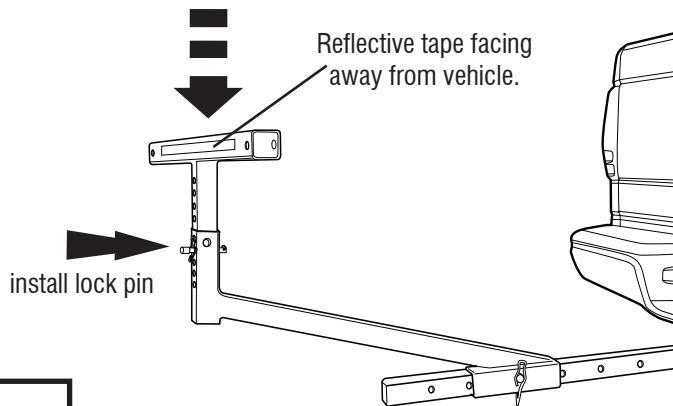

3

Install wings into T bar. Secure in place with  
(2) lock pins.

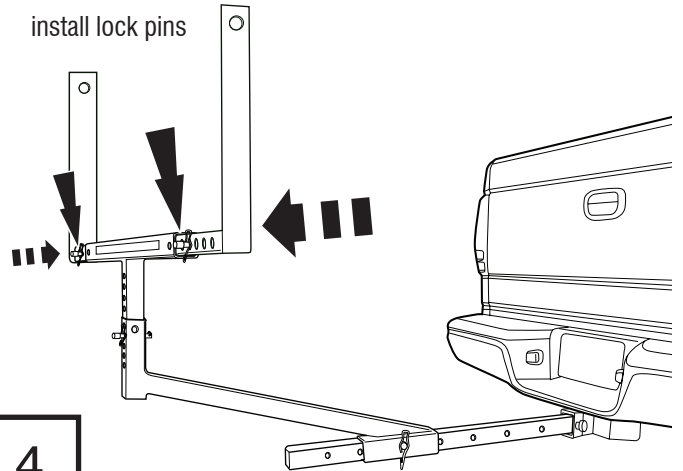

4

Install safety flag to secondary support tube.  
Secure in place with lock pin.

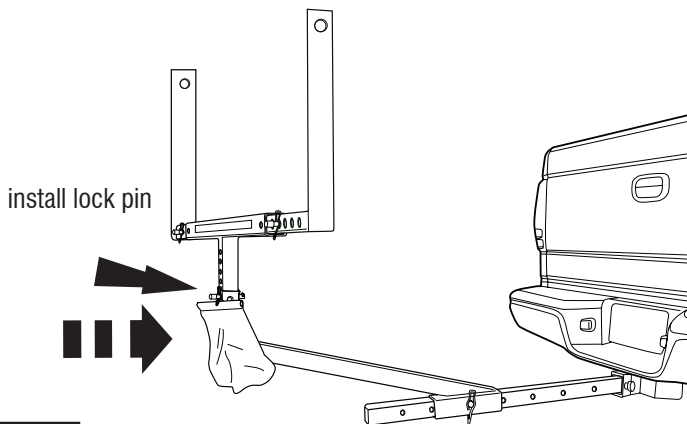

5

Lower tailgate of vehicle. Adjust height of T  
bar to be level with truck bed.

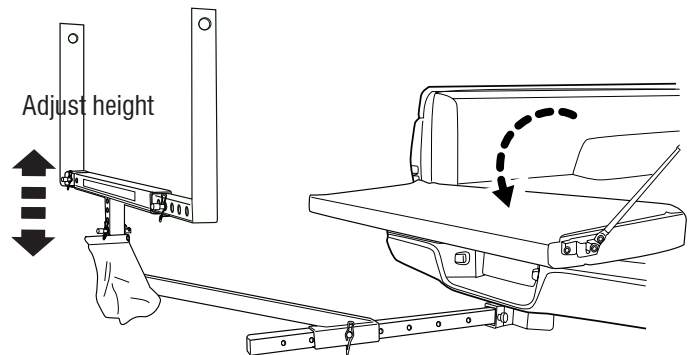

6

**NOTE:** Wings can be removed, rotated 90 degrees, and reinstalled to create a flat workspace support.

## SUV INSTALL

Insert Extension (if needed) into receiver. Insert hitch  
pin. (Hitch pin not supplied).

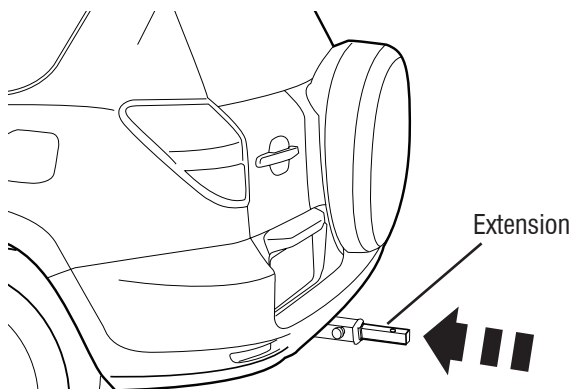

7

**NOTE:** Do not use product in horizontal position when vehicle is running to prevent exhaust gases from entering passenger area.

Insert secondary support tube over extension and  
install lock pin.

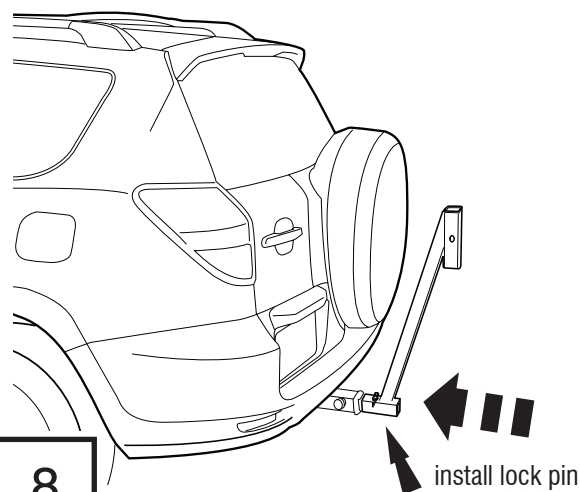

8

## Installation Steps

**NOTE:** Actual application may vary slightly from drawings.

Insert primary support tube over secondary support tube and install lock pin.

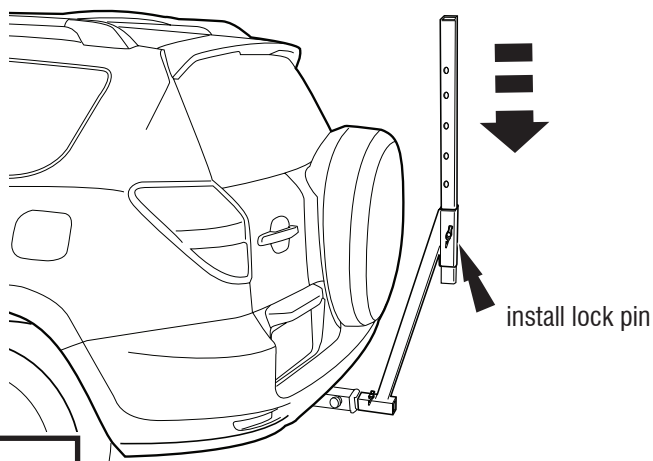

9

Install T bar into primary support tube. Secure in place with lock pin.

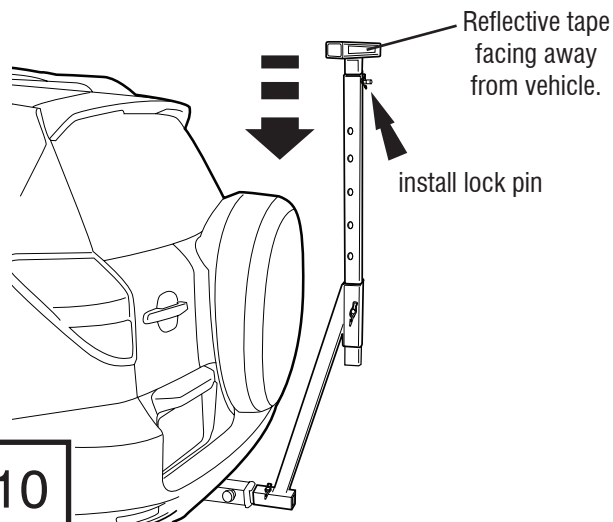

10

Install wings into T bar. Secure in place with (2) lock pins.

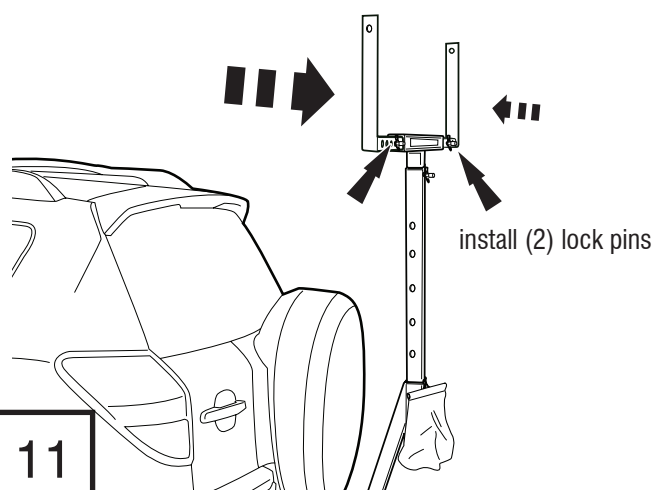

11

Adjust height of primary support tube as necessary to align with roof height. Install safety flag and secure in place with lock pin.

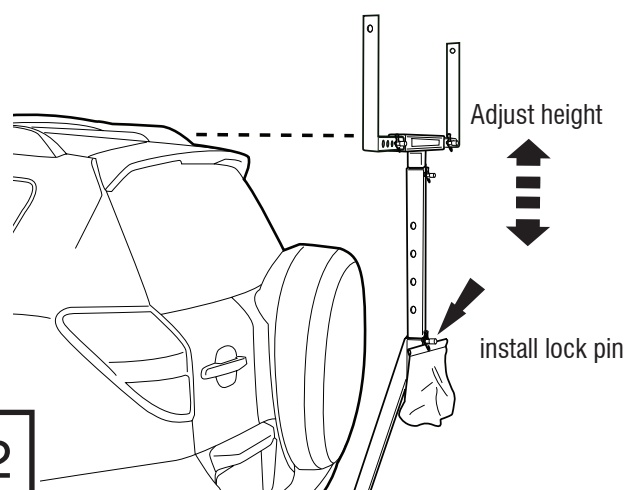

12

**WARNING:** Do not block taillights, brake lights, or turn signals. Always install T-bar with reflective tape facing away from vehicle. Do not use after dark or in low light conditions.

## Congratulations!

You have purchased one of the many quality Lund<sup>®</sup> branded products offered by Lund International, Inc. We take the utmost pride in our products and want you to enjoy years of satisfaction from your investment. We have made every effort to ensure that your product is top quality in terms of fit, durability, finish and ease of installation.



**LUND**

