

PARTS LIST:

1	3-1/2" Bull Bar	4	10mm Hex Nuts
1	Driver/left Frame Mounting Bracket	1	Allen Wrench
1	Passenger/right Frame Mounting Bracket	1	Wiring Harness
2	Spacers		
1	Lightbar		
4	10-1.5mm x 30mm Hex Bolts		
8	10mm x 27mm OD x 3mm Flat Washers		

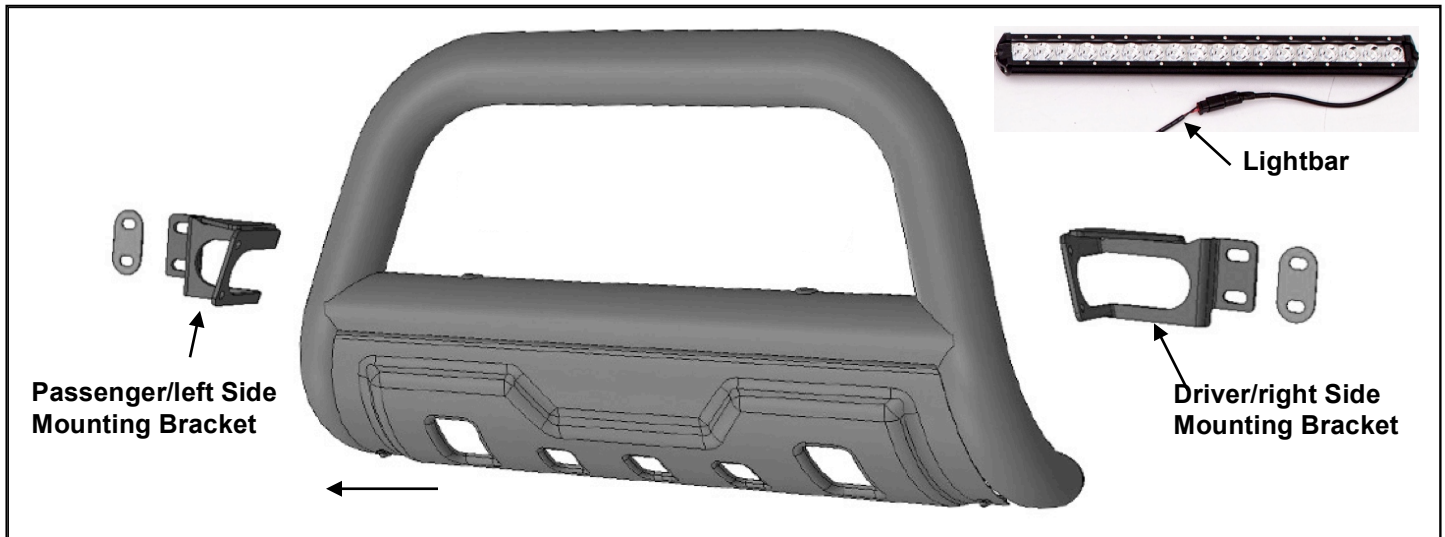

EQUIPMENT NEEDED:

- Safety Glasses
- Ratchet Set
- Pliers or Adjustable Wrench

IMPORTANT NOTES:

- Bull Bar *may* interfere with parking sensors on the bumper.
- The LED light bar can be wired into the factory light wiring or a wiring harness can be purchased separately.
- If state law requires a front license plate, a relocation kit is available separately.
- For cleaning, mild soap may be used to clean the Bull Bar, and aluminum polish may be used on the stainless steel to polish small scratches and scuffs on the finish.
- REMOVE CONTENTS FROM BOX, VERIFY ALL PARTS ARE PRESENT, & READ INSTRUCTIONS CAREFULLY. **NOTE: PROFESSIONAL INSTALLATION IS RECOMMENDED.**

LIGHT BAR INSTALLATION:

1. Remove light bar from box and screw bolts and washers into each end.
2. Slide bolts into crossbeam brackets with the washers on the outside of the bracket, and tighten using the supplied allen key.

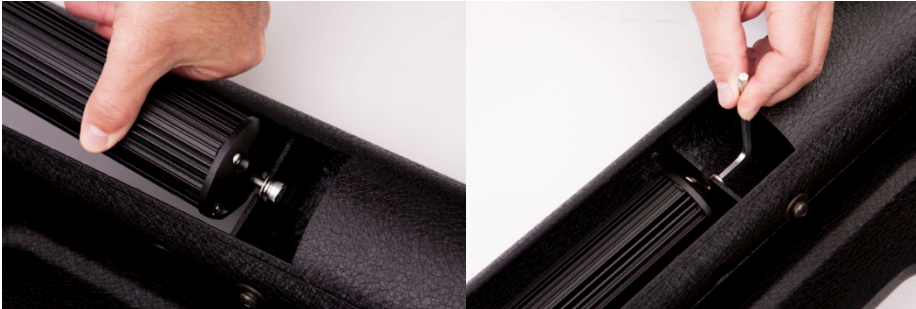

PROCEDURE:

REMOVE CONTENTS FROM BOX. VERIFY ALL PARTS ARE PRESENT. READ INSTRUCTIONS CAREFULLY BEFORE STARTING INSTALLATION. ASSISTANCE IS RECOMMENDED.

NOTE: It may be necessary to remove/relocate front license plate and bracket. It is not required, but strongly recommended. If local/state law requires a license plate, license plate relocation kit is available.

1. Start installation at the driver/left side, front of the vehicle. Remove the plastic cover, (if equipped), covering the bumper bolts on both sides of the tow hook, **(Figure 1)**. Remove the (2) outer bumper bolts, **(Figures 2 & 3)**. **IMPORTANT:** Do not remove the inner bumper bolts or the bumper may fall. Only remove the outer bumper bolts. **NOTE:** Cover cannot be reinstalled.
2. Select the driver side Frame Bracket and (1) Spacer Plate, **(Figure 4)**. Place the Spacer over the holes for the bumper bolts. Reuse the factory bumper bolts to attach the Frame Bracket to the Spacer and bumper, **(Figure 5)**. Make sure there is clearance between the top and bottom of the Frame Bracket and the opening in the bumper. Do not tighten hardware at this time.
3. Repeat **Steps 1 & 2** for passenger/right side Frame Bracket and Spacer installation.
4. With assistance, position the Bull Bar onto the outside of the (2) Mounting Brackets, **(Figure 6)**. **NOTE:** Move the Mounting Brackets in or out as required to line up with the mounting tabs on the Bull Bar.
5. Attach the Bull Bar to the outside of the Mounting Brackets using the included (4) 10mm x 30mm Hex Bolts, (8) 10mm Flat Washers, (4) 10mm Nylon Lock Nuts, **(Figure 6)**. Snug but do not tighten hardware at this time.
6. Center the Bull Bar on the vehicle, level and adjust as desired and tighten all hardware at this time.
7. Do periodic inspections to the installation to make sure that all hardware is secure and tight.

To protect your investment, wax this product after installing. Regular waxing is recommended to add a protective layer over the finish. Do not use any type of polish or wax that may contain abrasives that could damage the finish.

For stainless steel: Aluminum polish may be used to polish small scratches and scuffs on the finish. Mild soap may be used also to clean the Bull Bar. **For gloss black finishes:** Mild soap may be used to clean the Bull Bar.

Passenger Side Installation Pictured

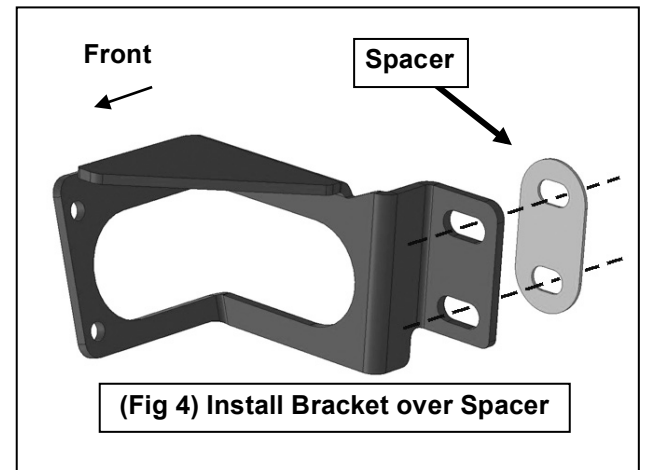
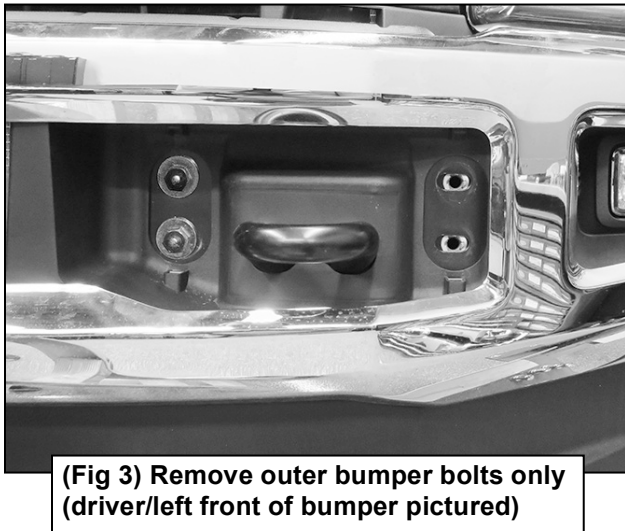
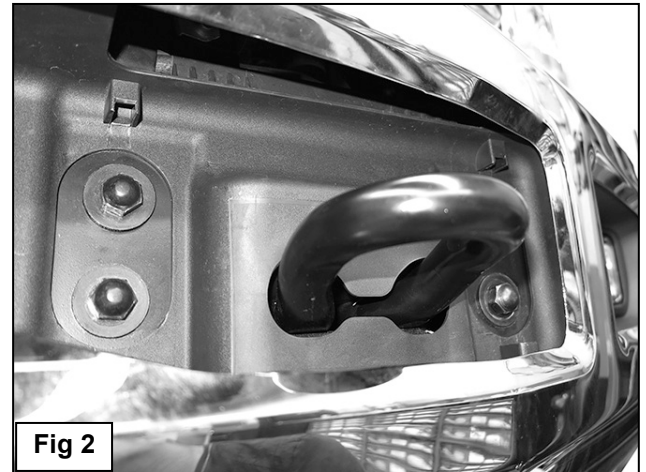

Passenger Side Installation Pictured

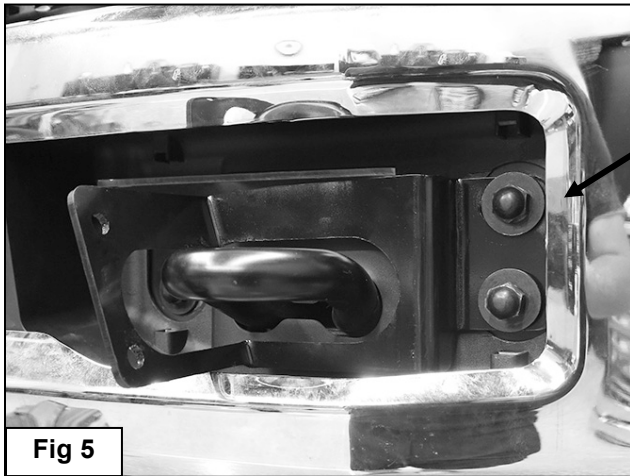
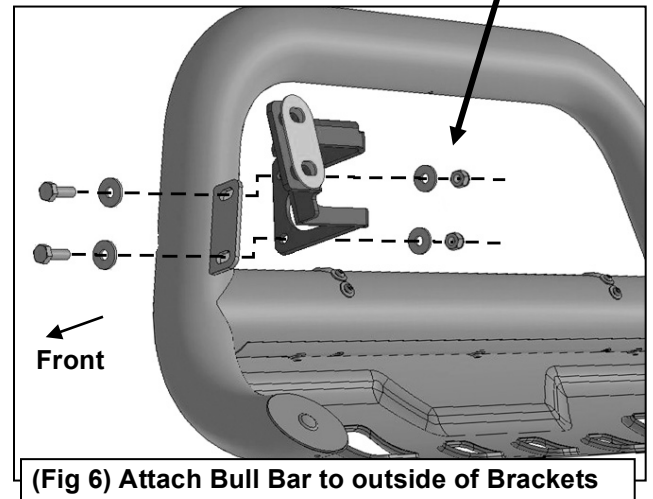

Fig 5

Reuse factory bumper bolts to attach Bracket and Spacer to Bumper

(2) 10mm x 30mm Hex Bolts
(4) 10mm Flat Washers
(2) 10mm Nylon Lock Nuts



(Fig 6) Attach Bull Bar to outside of Brackets