

PARTS LIST:

Qty	Description	Qty	Description
1	3.5in Oval Bull Bar	2	10mm U-Bolt (for use on "closed frames" only)
1	Driver side Frame Bracket	4	10-1.50mm x 35mm Hex Bolts
1	Passenger Side Frame Bracket	12	10mm x 27mm OD x 3mm Flat Washers
2	Bull Bar Mounting Brackets	8	10-1.50mm Nylon Lock Nuts
1	LED Light Bar	4	8-1.25mm x 35mm Hex Bolts
4	12mm x 40mm Bolt Plates	4	8mm x 22mm OD x 2mm Flat Washers
4	12mm x 32mm OD x 3mm Flat Washer	4	8mm Lock Washers
4	12mm Lock Washers		
4	12-1.75mm Hex Nuts		

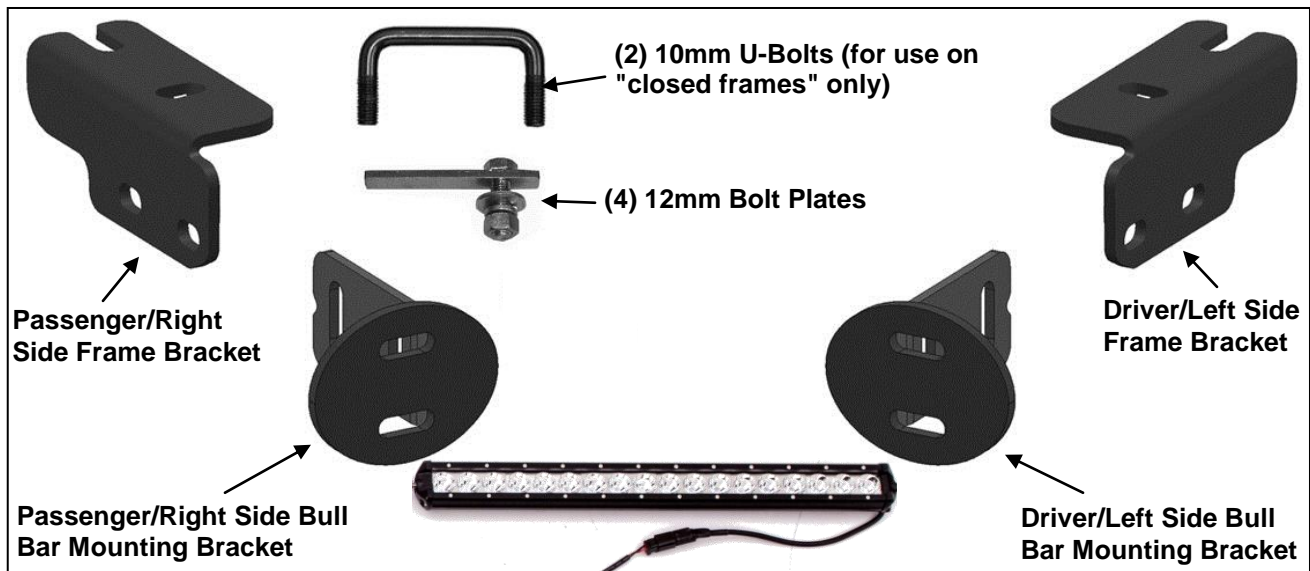

EQUIPMENT NEEDED:

- Safety Glasses
- Ratchet Set
- Pliers or Adjustable Wrench

IMPORTANT NOTES:

- Bull Bar *may* interfere with parking sensors on the bumper.
- The LED light bar can be wired into the factory lighting, or a wiring harness can be purchased separately.
- If state law requires a front license plate, a relocation kit is available separately.
- For cleaning, mild soap may be used to clean the Bull Bar, and aluminum polish may be used on the stainless steel to polish small scratches and scuffs on the finish.
- REMOVE CONTENTS FROM BOX, VERIFY ALL PARTS ARE PRESENT, & READ INSTRUCTIONS CAREFULLY. **NOTE: PROFESSIONAL INSTALLATION IS RECOMMENDED.**

LIGHT BAR INSTALLATION:

1. Remove light bar from box and screw bolts and washers into each end.
2. Slide bolts into crossbeam brackets with the washers on the outside of the bracket, and tighten using the supplied allen key.



BULL BAR INSTALLATION:

1. Determine if the vehicle is equipped with tow hooks

Vehicles with Factory Tow Hooks

- a. Remove each tow hook by removing the front bolt and only loosening the rear bolt, **(Figure 2)**. Slide the tow hook off. Keep the factory double nut plate in the frame and aligned with the holes. **NOTE:** Tow hooks cannot be reinstalled.

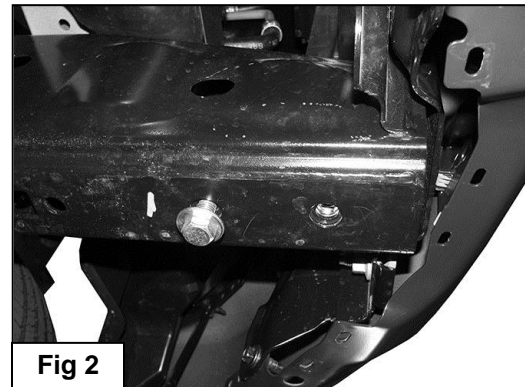
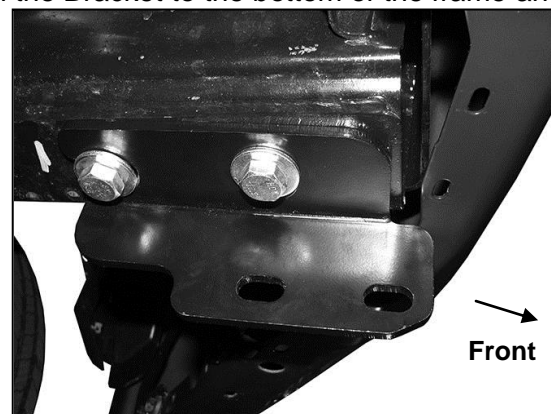

Fig 2

- b. Select the driver side Frame Bracket. Position the Bracket up to the bottom of the frame. Reuse the tow hook hardware to attach the Bracket to the bottom of the frame and factory double nut plate, **(Figure 3)**.



(Fig 3) Reuse the factory tow hook bolts

- c. Repeat to install the passenger side Frame Bracket.
- d. Skip to **Step 3**.

All vehicles without Tow Hooks

Remove the lower plastic portion of the bumper to gain access to the ends of the frame rails, (**Figure 4**). The lower bumper or splash guard will need to be cut out to allow the Mounting Brackets and end of Bull Bar to pass through. On some models, access to the mounting hardware is limited. For access, first remove the plastic bumper cover from each side of the opening and in the center of the bumper, (**Figure 5**).

(Fig 4) Temporarily remove the splash guard as required to gain access to the front of the frame channel.



(Fig 5) Remove bumper pads to access splash guard hardware if necessary. 2015 F150 pictured

Vehicles without Tow Hooks and open end of frame

- a. Starting on the driver side of the vehicle, insert (1) 12mm Bolt Plate through the opening in the end of the frame and down through the rear hole in the bottom of the frame, (**Figure 6A**). Thread (1) 12mm Flat Washer, (1) 12mm Lock Washer and (1) 12mm Hex Nut onto the end of the Bolt Plate.

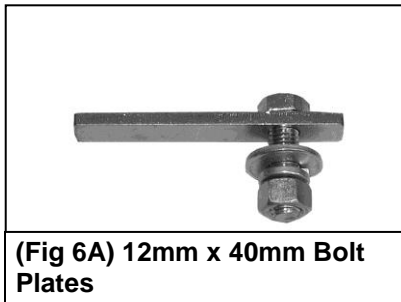

(Fig 6A) 12mm x 40mm Bolt Plates

- b. Slide the slotted end of the driver side Bracket under the nut and washers. Insert the second 12mm Bolt Plate through the remaining hole toward the front of the Mounting Bracket. Secure the Bracket to the Bolt Plate with (1) 12mm Lock Washer, (1) 12mm Flat Washer and (1) 12mm Hex Nut, (**Figure 6B**).

Insert Bolt Plates through open end of frame

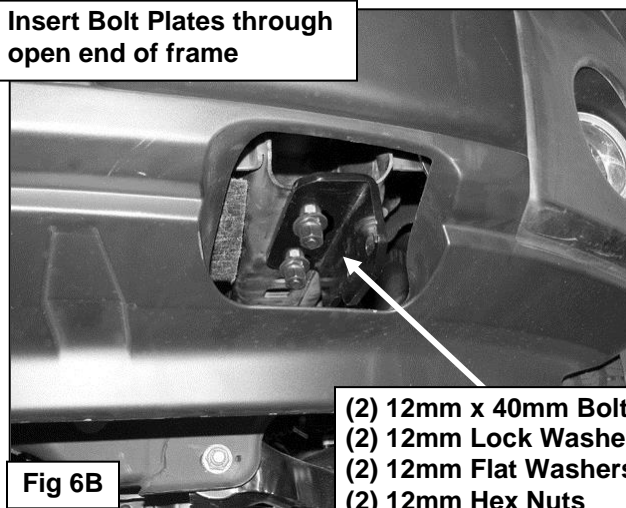

Fig 6B

- (2) 12mm x 40mm Bolt Plates
- (2) 12mm Lock Washers
- (2) 12mm Flat Washers
- (2) 12mm Hex Nuts

- c. Snug but do not tighten the hardware at this time.
- d. Repeat to install the passenger side frame bracket.

Vehicles without Tow Hooks, closed end of frame

- a. Starting on the driver side of the vehicle, locate the two holes on the bottom of the frame. Insert (1) 10mm U-Bolt into one hole and out the other, **(Figures 7A & 7B)**.

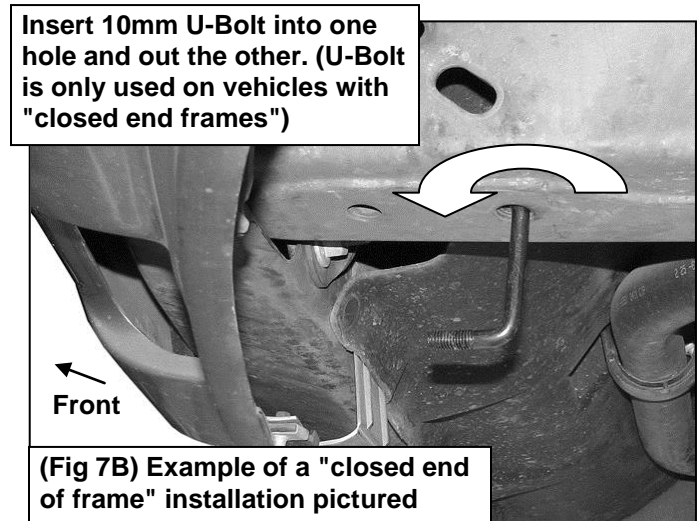
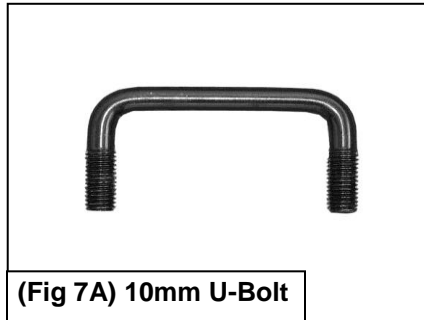

- b. Hold the driver side Bracket up in position with the slotted end toward the rear. Secure the Bracket to the U-Bolt with (2) 10mm Flat Washers and (2) 10mm Nylon Lock Nuts, **(Figure 8)**.

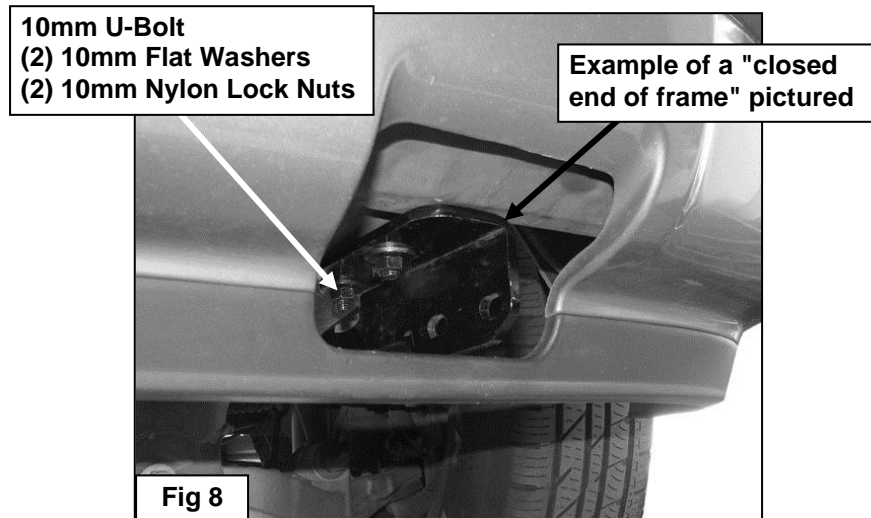

- c. Snug but do not tighten the hardware.
- d. Repeat to install the passenger side frame Bracket.

2. Next, carefully unwrap the Bull Bar. Select the driver side Bull Bar Mounting Bracket, **(Figure 9)**. Attach the Bracket to the end of the Bull Bar with (2) 8mm x 35mm Hex Bolts, (2) 8mm Lock Washers and (2) 8mm Flat Washers, **(Figures 10A & 10B)**. Center the mounting flange on the Bracket with the end of the tube on the Bull Bar. Snug but do not tighten hardware. Repeat this Step to install the passenger side Mounting Bracket.

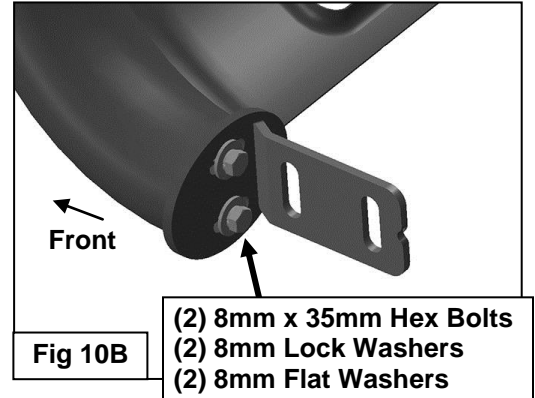
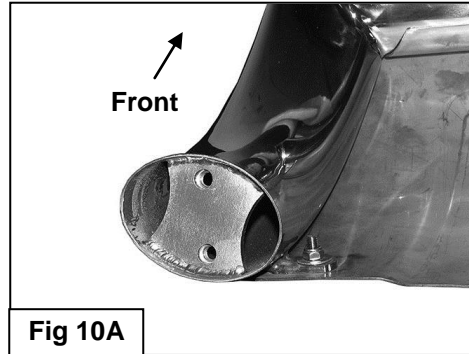
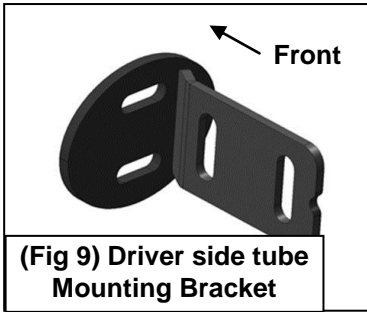

3. With assistance, line up the mounting tabs on the Bull Bar with the inside of the (2) previously installed Frame Mounting Brackets. Bolt the Bull Bar to the Brackets with the included (4) 10mm x 35mm Hex Bolts, (8) 10mm Flat Washers, (4) 10mm Nylon Lock Nuts, **(Figure 11)**. Snug but do not tighten hardware at this time.

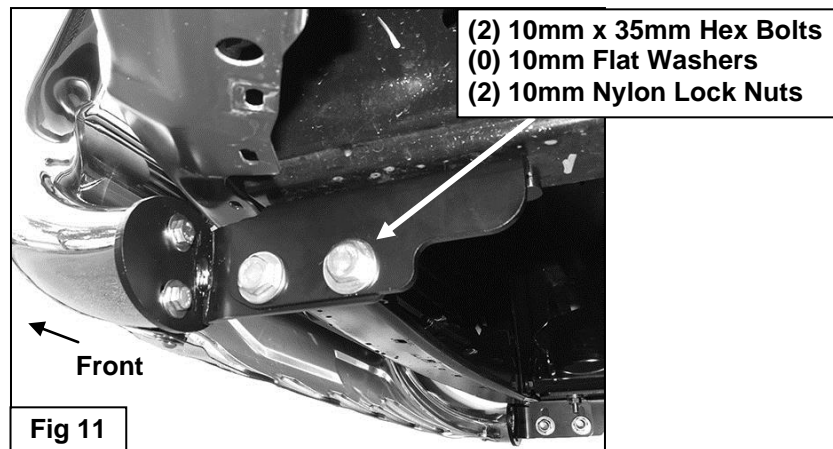

4. Level and adjust the Bull Bar properly and tighten all hardware.

Models without openings in lower bumper or splash guard for tow hooks. Hold the cover up to the bottom of the bumper, (**Figure 12A**). Trace the location of both Brackets onto the back of the cover. Temporarily remove the Bull Bar with attached Tube Brackets only. Cut openings in the cover to clear the Frame Brackets and end of Bull Bar as necessary, (**Figure 12B**). For best results, start with a small slot and slowly enlarge the opening to clear the Brackets. Once cover is properly fit to the Brackets, reinstall the cover and Bull Bar as previously described.

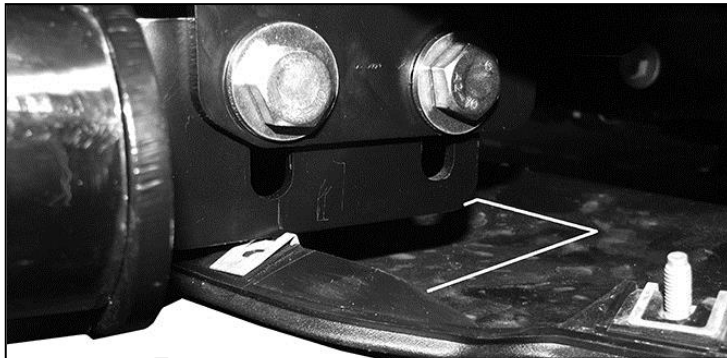
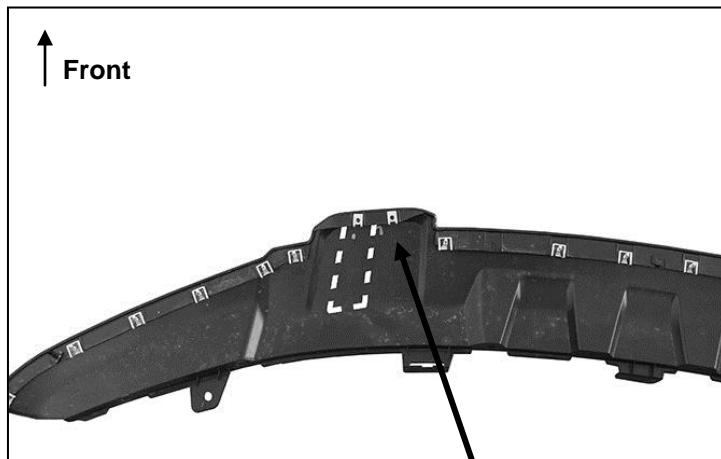

Fig 12A

Hold the splash guard up to the bottom of the Brackets. Trace the location of the Brackets onto the inside of the splash guard. Use a sharp knife or hacksaw blade to cut out the plastic cover. Only cut enough to clear the Brackets, do not cut through the front or rear edges of the cover.



(Fig 12B) Only cut enough to clear the Brackets, do not cut through the front or rear edges of the cover.