

Installation Instructions

LUND Running Boards

Important Safety Information



- CAUTION - Before driving, ensure that the Running Boards are properly anchored to vehicle.
- Do not use automatic "brush-style" car washes.
- Do not use cleaning solvents of any kind.
- Periodically check all components for tightness.

Contents **NOTE:** Actual product may vary from illustration.

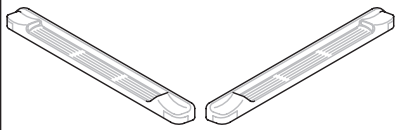

Running Boards



Brackets
2053-11 (8)



8mm x 20mm
(5/16" x 3/4) Bolts (8)



M8mm (5/16")
Flanged Nuts (8)



5/16" x 3/4" Square
Bolts (16)



Washers
(16)



5/16" Flanged
Nuts (16)

Tools Required



Socket Set



Screwdriver

Preparation Before Painting/Installation

- A trial fit is recommended to ensure proper positioning and fit.
- Check fit of parts before painting as we will not accept the return of modified or painted parts.

Installation Steps **NOTE:** Actual application may vary slightly from illustrations.



Attach brackets to rocker panel.

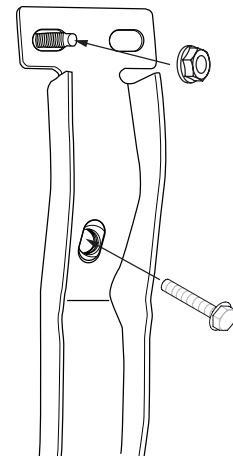
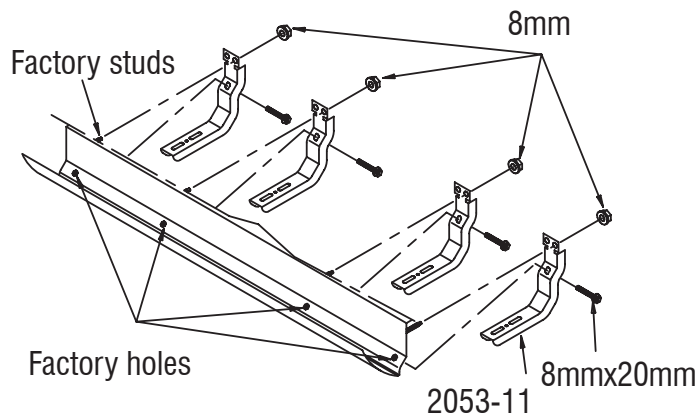

1

Installation Steps

NOTE: Actual application may vary slightly from drawings.

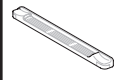

Install square bolts into the shaded outer channels. Four (4) per channel to attach boards to brackets.

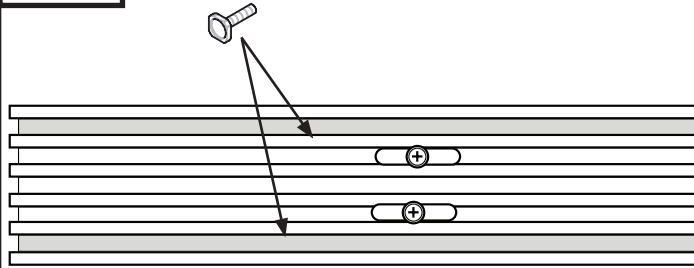

Attach boards to brackets.

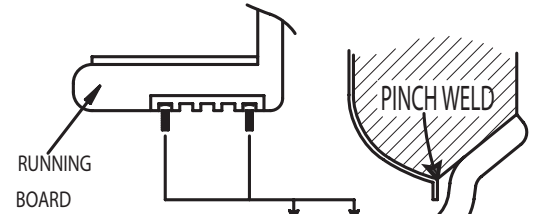

5/16"x18 Washer

5/16"x18 Flanged Nut

2

3

Care and Cleaning

- Wash only with mild soap & dry with a clean cloth.

Congratulations!

You have purchased one of the many quality Lund[®] branded products offered by Lund International, Inc. We take the utmost pride in our products and want you to enjoy years of satisfaction from your investment. We have made every effort to ensure that your product is top quality in terms of fit, durability, finish and ease of installation.

Lund provides the best in running boards and step bars equipment.

