

Installation Instructions

I - Sheet Number LUNDSR202



Premium Style. Lasting Performance.

For proper installation and best possible fit, please read all instructions BEFORE you begin.

Care and Cleaning

- Wash only with mild soap and dry with a clean cloth.
- Every 3 months or 5000 miles check for loose hardware and tighten as necessary.

Congratulations!

You have purchased one of the many quality Lund® branded products offered by Lund International, Inc. We take the utmost pride in our products and want you to enjoy years of satisfaction from your investment. We have made every effort to ensure that your product is top quality in terms of fit, durability, finish and ease of installation.

SR2 RUNNING BOARDS
15-18 F150 CREW CAB & 2017 F250-350 SUPER DUTY CREW CAB

PARTS LIST:

2	91" SR2 Running Boards	30	8mm x 24mm x 2mm Washers
6	Universal Mounting Brackets (left or right)	30	8-1.25mm Nylon Lock Nuts
18	8mm Plastic Washers	6	8mm Double Bolt Plates

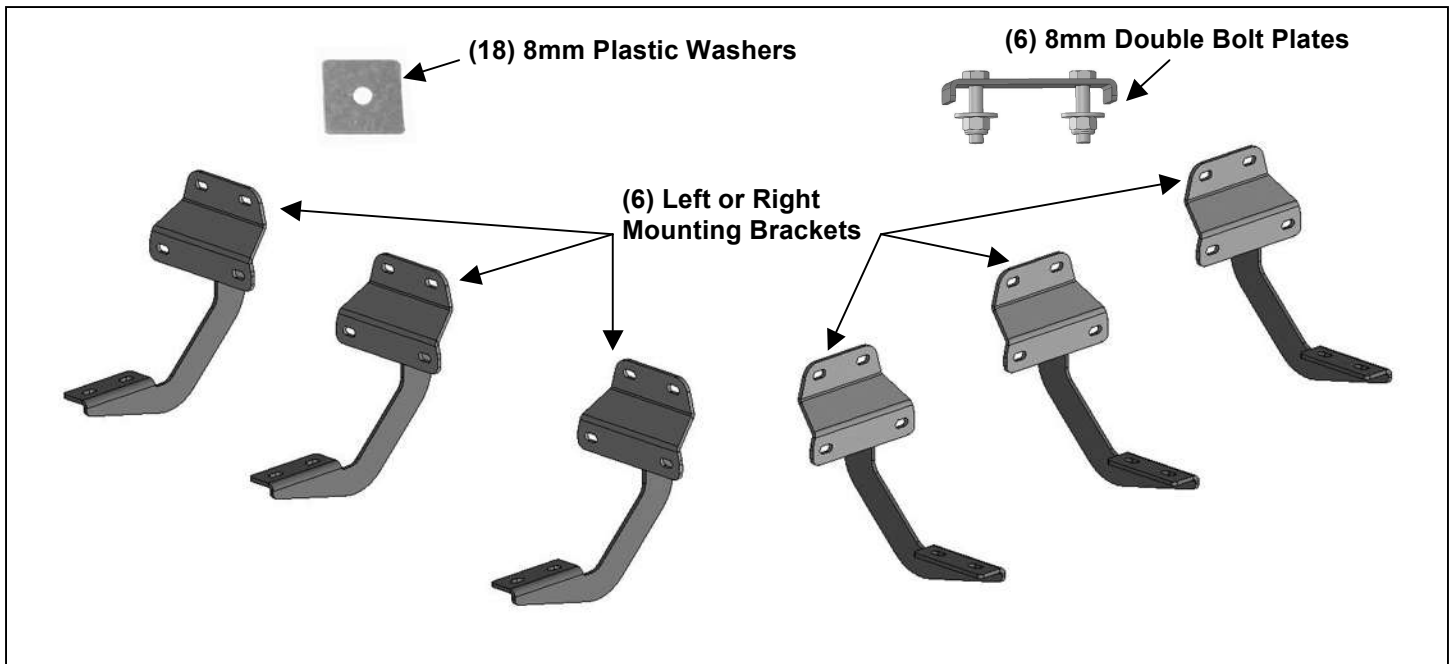

PROCEDURE:

REMOVE CONTENTS FROM BOX. VERIFY ALL PARTS ARE PRESENT. READ INSTRUCTIONS CAREFULLY BEFORE STARTING INSTALLATION. ASSISTANCE IS RECOMMENDED.

1. Start the installation under the passenger side of the vehicle. Locate the front factory running board mounting location along the inner side of the body, **(Figure 1)**.
2. Slide (1) Plastic Washer over each of the (3) factory mounting studs in the body panel, **(Figures 2 & 3)**. **IMPORTANT:** The Plastic Washers are designed to prevent corrosion between the aluminum body panel and the steel mounting brackets. **Do not install the Brackets without the Plastic Washers.**
3. Select (1) Mounting Bracket. **NOTE:** All (6) Brackets are universal and will fit left or right side. Attach the Mounting Bracket to the (3) factory studs with (3) 8mm Flat Washers and (3) 8mm Nylon Lock Nuts, **(Figures 4 & 5)**. Leave brackets loose at this time.
4. Repeat **Steps 1—3** to install the center and rear passenger side Brackets, **(Figures 6 & 7)**.
5. Select (1) SR2 Running Board. Place the Running Board on top of the Brackets. Locate the channels in the bottom of the Running Board. Select (3) 8mm Double Bolt Plates, **(Figure 8)**. Insert the Bolt Plates into the channels in the bottom of the Running Board closest to the Brackets, **(Figure 9)**. Lift the Running Board up and guide the studs through the Brackets.
6. Attach the Running Board to the Brackets with (6) 8mm Flat Washers and (6) 8mm Nylon Lock Nuts, **(Figures 10 — 12)**. **NOTE:** The Running Board is designed to fit close to the vehicle. It may be necessary to loosen the Bracket hardware slightly and tilt the Brackets downward to insert the Running Board between the Brackets and the body. Do not tighten hardware.
7. **NOTE:** Adjust the Running Board approximately 2" back from the front wheel opening.
8. Level and adjust the Running Board as necessary and fully tighten all hardware.
9. Repeat **Steps 1—8** for the driver side Running Board installation.
10. Do periodic inspections to the installation to make sure that all hardware is secure and tight.

SR2 RUNNING BOARDS

15-18 F150 CREW CAB & 2017 F250-350 SUPER DUTY CREW CAB

To protect your investment, wax this product after installing. Regular waxing is recommended to add a protective layer over the finish. Do not use any type of polish or wax that may contain abrasives that could damage the finish. Mild soap may be used also to clean the Running Board.

Passenger/right Side Installation Pictured

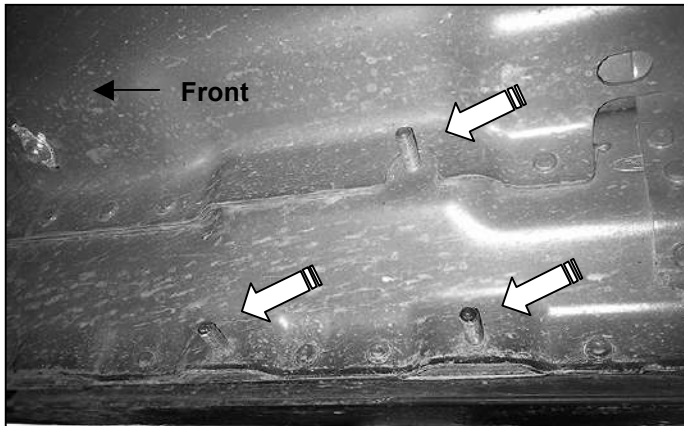

(Fig 1) Passenger side front mounting location

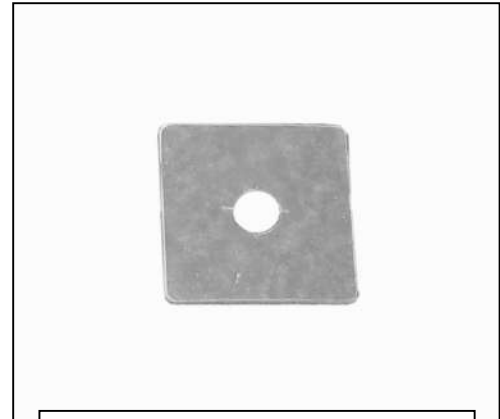

(Fig 2) Plastic Insulation Washer

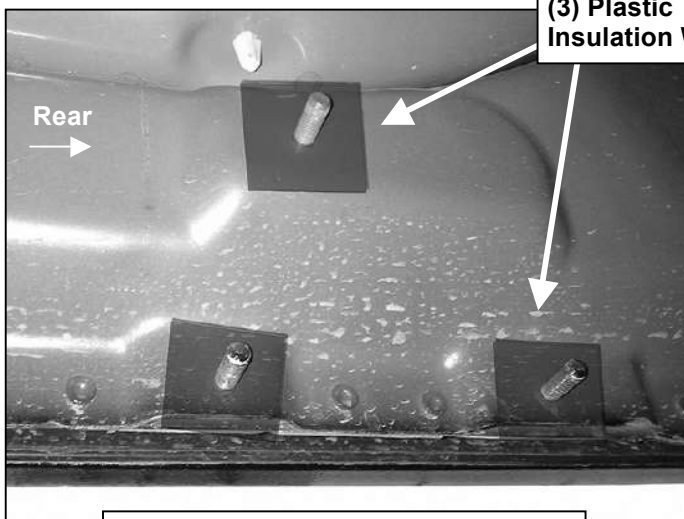

(Fig 3) Thread Plastic Washers onto all mounting studs. Passenger side rear mounting location pictured

- (3) 8mm Plastic Washers
- (3) 8mm Flat Washers
- (3) 8mm Nylon Lock Nuts

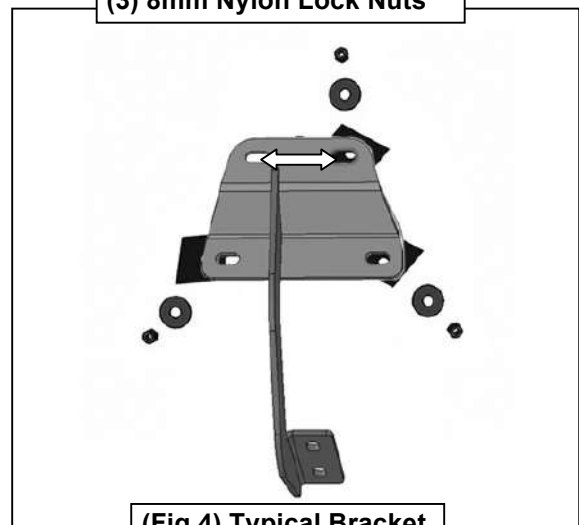

(Fig 4) Typical Bracket installation illustrated

SR2 RUNNING BOARDS
15-18 F150 CREW CAB & 2017 F250-350 SUPER DUTY CREW CAB

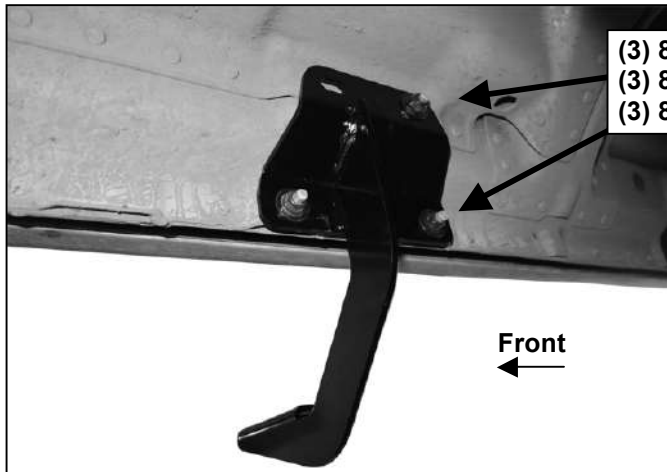

- (3) 8mm Plastic Washers
- (3) 8mm Flat Washers
- (3) 8mm Nylon Lock Nuts

(Fig 5) Passenger side front Bracket installed

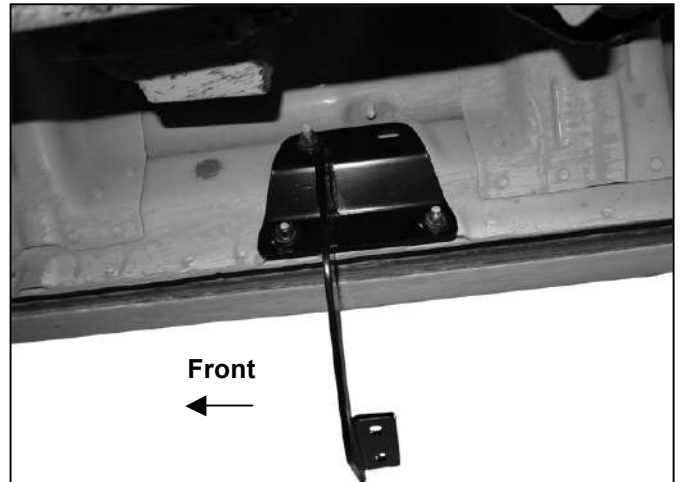

(Fig 6) Passenger side center Bracket installed

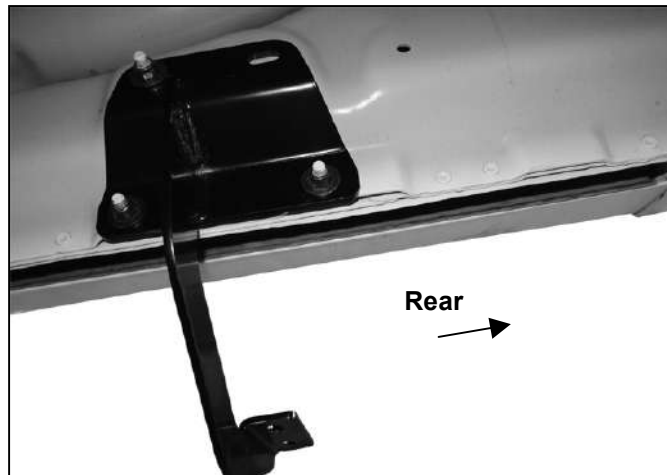

(Fig 7) Passenger Side Rear Bracket installed

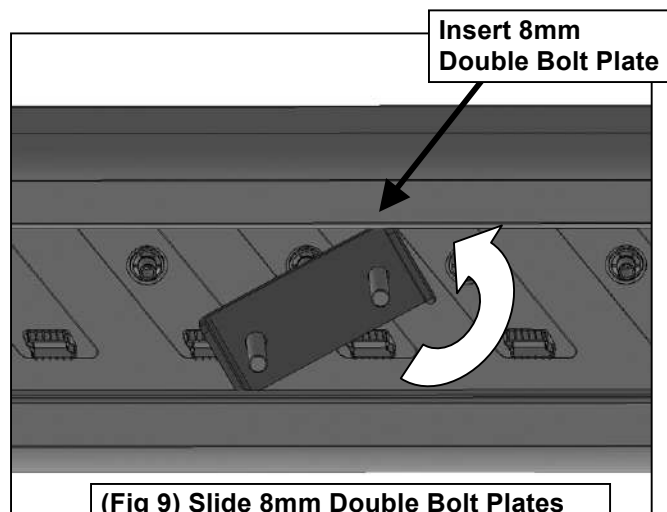

(Fig 9) Slide 8mm Double Bolt Plates into track on bottom of Running Board

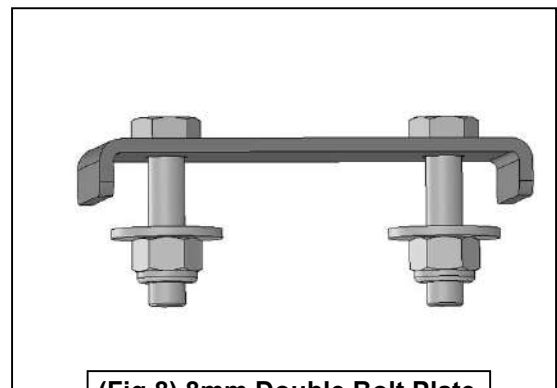

(Fig 8) 8mm Double Bolt Plate

**SR2 RUNNING BOARDS
15-18 F150 CREW CAB & 2017 F250-350 SUPER DUTY CREW CAB**

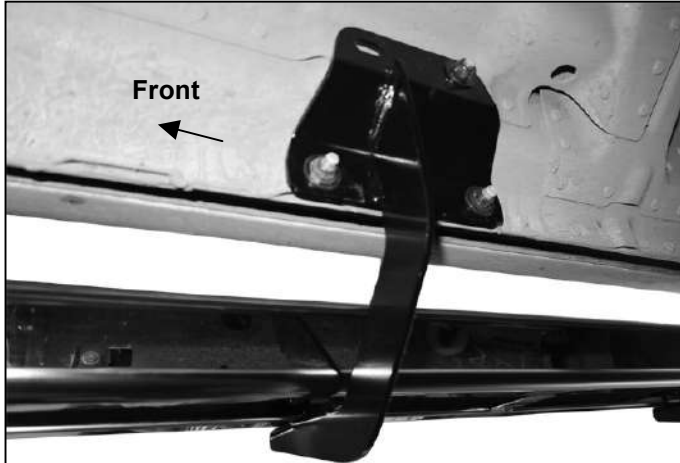

(Fig 10) Passenger side front complete installation

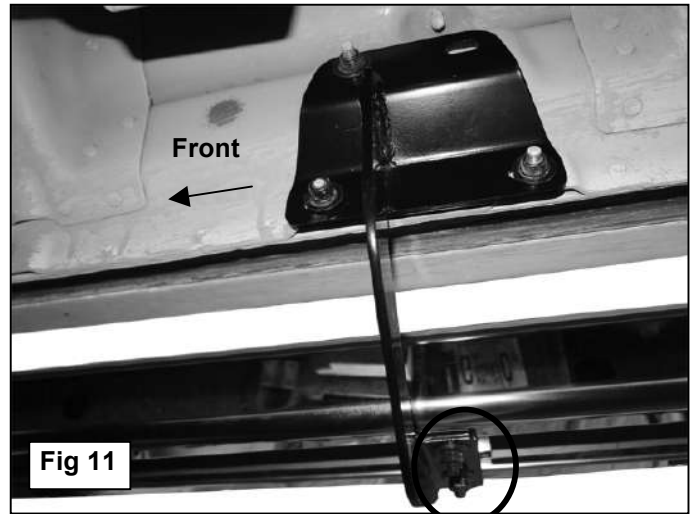

- (2) 8mm Flat Washers
- (2) 8mm Nylon Lock Nuts

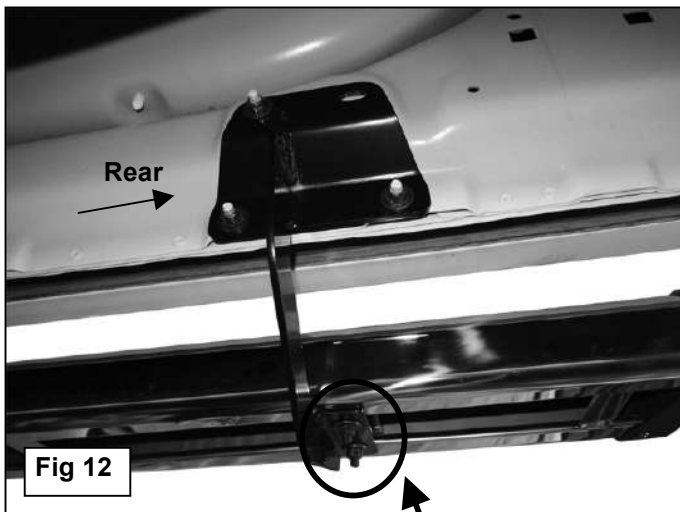

- (2) 8mm Flat Washers
- (2) 8mm Nylon Lock Nuts

