

Installation Instructions



Premium Style. Lasting Performance.

For proper installation and best possible fit, please read all instructions BEFORE you begin.

Care and Cleaning

- Wash only with mild soap and dry with a clean cloth.
- Every 3 months or 5000 miles check for loose hardware and tighten as necessary.

Congratulations!

You have purchased one of the many quality Lund® branded products offered by Lund International, Inc. We take the utmost pride in our products and want you to enjoy years of satisfaction from your investment. We have made every effort to ensure that your product is top quality in terms of fit, durability, finish and ease of installation.

SR2 RUNNING BOARDS 99-16 FORD 250/350/450/550 SUPERDUTY SUPERCREW

PARTS LIST:

2	SR2 Running Boards(91")	48	8mm x 24mm x 2mm Flat Washers
3	Driver/left side Mounting Brackets	12	8mm Lock Washers
3	Passenger/right side Mounting Brackets	24	8mm Nylon Lock Nuts
24	8-1.25mm x 30mm Hex Bolts	6	8mm Double Bolt Plates
12	8mm Clip Nuts		

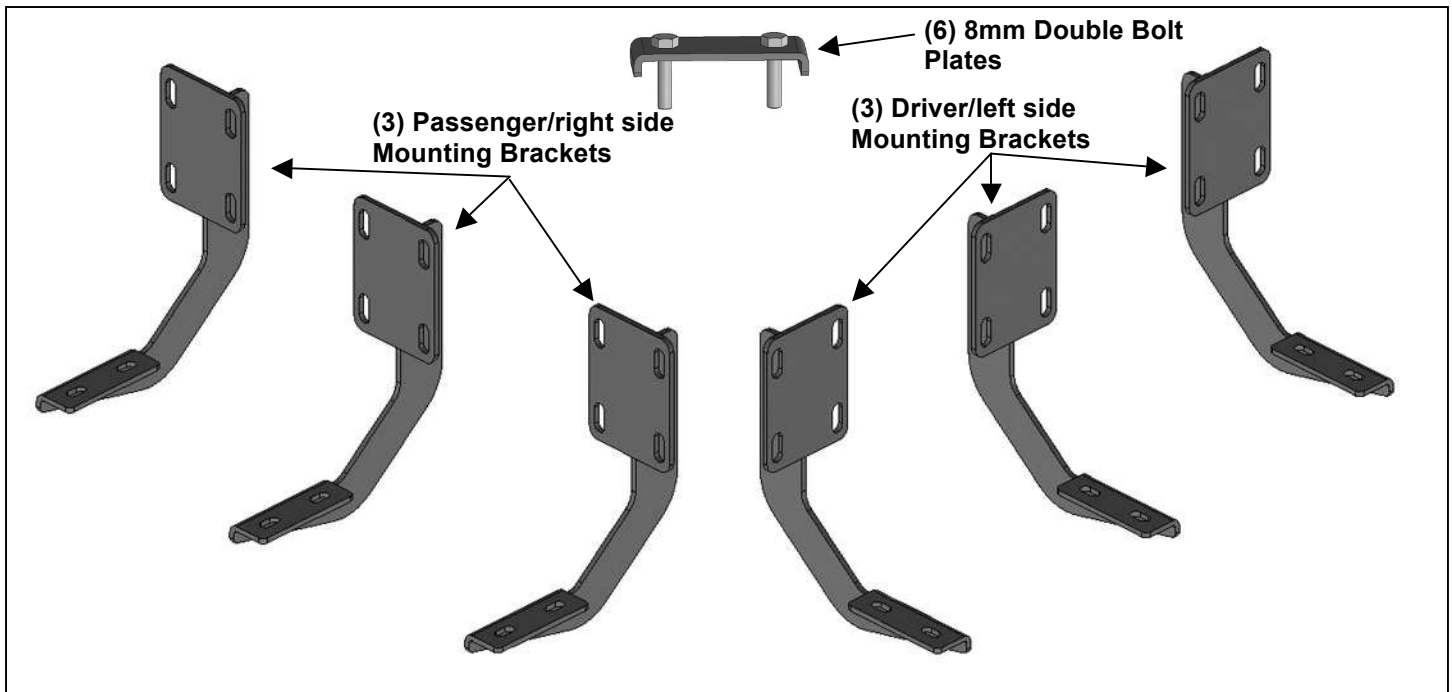

PROCEDURE:

1. REMOVE CONTENTS FROM BOX. VERIFY ALL PARTS ARE PRESENT. READ INSTRUCTIONS CAREFULLY BEFORE STARTING INSTALLATION.
2. Starting on the driver front side of the vehicle, locate the (2) holes through the bottom of the pinch weld. Next, locate the rectangular opening and the (2) small hole in the inner body panel directly above the holes in the pinch weld, **(Figures 1 & 2)**. **NOTE:** The holes in the inner panel may be covered with sealing tape or insulation, remove as required.
3. Slide (2) 8mm “U” Clips into the rectangular opening with the nut towards the inside. Line up the threaded nut on the clips with the (2) small round holes, **(Figure 3)**.
4. Select (1) Driver side Mounting Bracket. Attach the top of the Bracket to the “U” Clips with (2) 8mm Hex Bolts, (2) 8mm Lock Washers and (2) 8mm Flat Washers, **(Figures 4 & 5)**. Line up the lower holes in the Bracket with the (2) holes through the pinch weld. Bolt the Bracket to the pinch weld with (2) 8mm Hex Bolts, (4) 8mm Flat Washers and (2) 8mm Nylon Lock Nuts, **(Figures 4 & 5)**. Snug but do not fully tighten Bracket hardware.
5. Move toward the center of the cab, **(Figure 6)**. Locate the pair of holes along the pinch weld. Use **Figure 1** to determine the correct mounting location for the rear Bracket. Repeat **Steps 2—4** to install (1) Driver side Mounting Bracket on the center location, **(Figure 7)**.
6. Move toward the rear of the cab, **(Figure 8)**. Locate the last pair of holes along the pinch weld. Use **Figure 1** to determine the correct mounting location for the rear Bracket. Repeat **Steps 2—4** to install (1) Driver side Mounting Bracket on the rear location, **(Figure 9)**.
7. Once the (3) Brackets have been fully installed, select (1) Running Board. Place the Running Board on top of the Brackets. Locate the channels in the bottom of the Running Board. Select (3) 8mm Double Bolt Plates, **(Figure 10)**. Insert the Bolt Plates into the channels in the bottom of the Running Board closest to the Brackets, **(Figure 11)**. Lift the Board up and guide the studs through the Brackets.
8. Attach the Running Board to the Brackets with (6) 8mm Flat Washers and (6) 8mm Nylon Lock Nuts, **(Figures 12—14)**.

SR2 RUNNING BOARDS

99-16 FORD 250/350/450/550 SUPERDUTY SUPERCREW

9. Level and adjust the Running Board as necessary and fully tighten all hardware.
10. Repeat **Steps 2—8** for passenger side Running Board installation.
11. Do periodic inspections to the installation to make sure that all hardware is secure and tight.

To protect your investment, wax this product after installing. Regular waxing is recommended to add a protective layer over the finish. Do not use any type of polish or wax that may contain abrasives that could damage the finish. Mild soap may be used to clean the Running Board.

Driver Side Installation Pictured

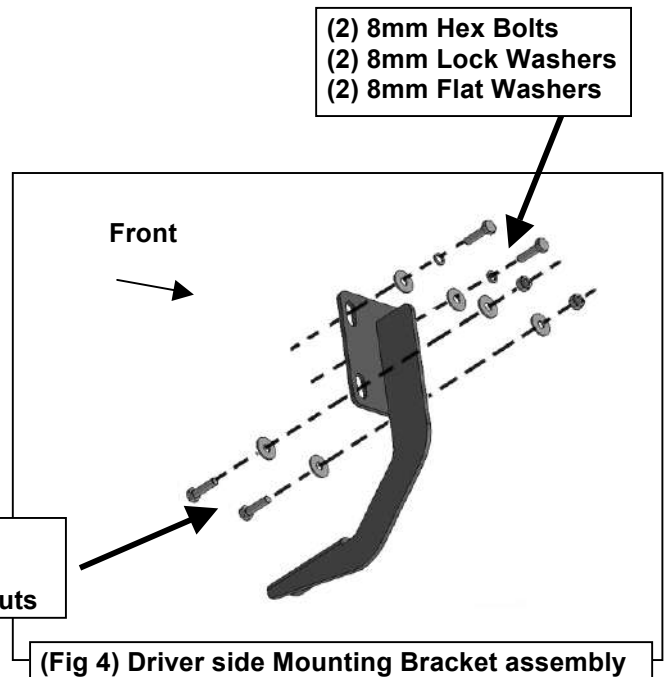
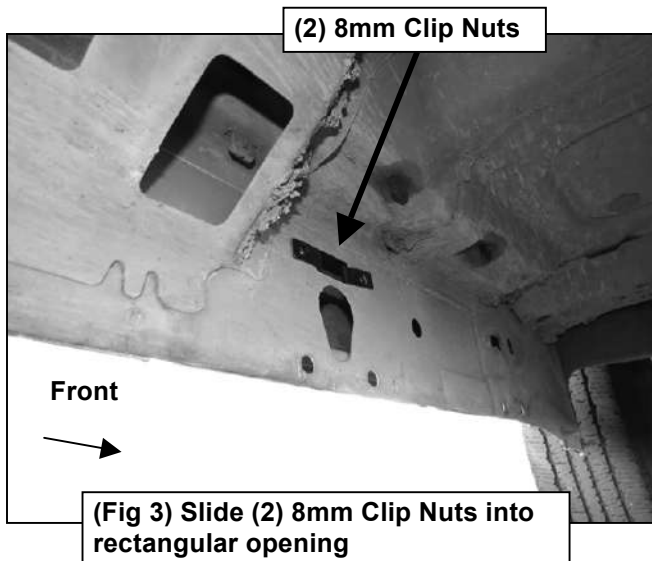
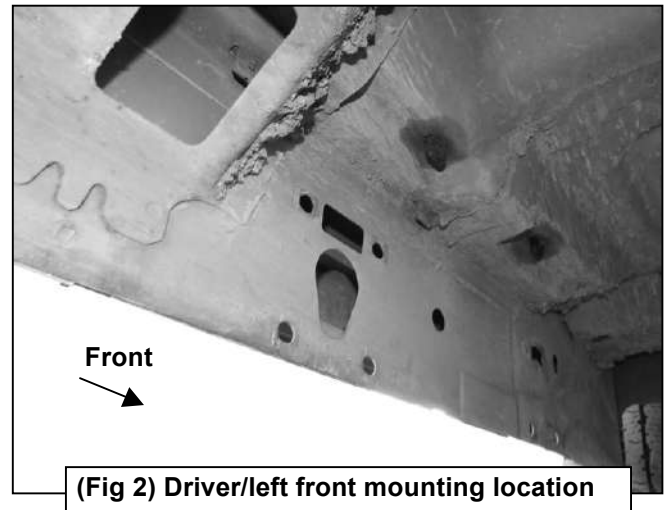
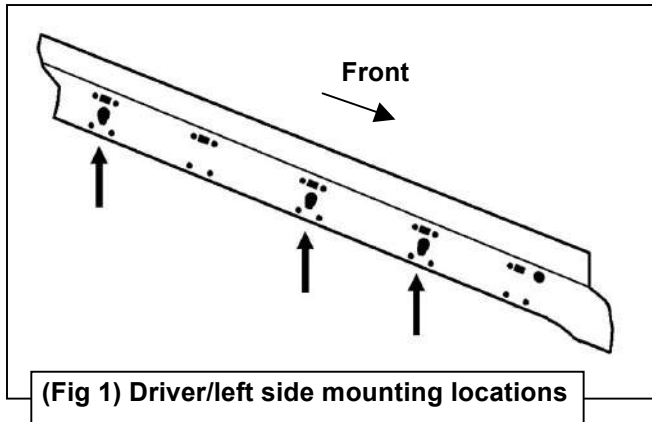

SR2 RUNNING BOARDS
99-16 FORD 250/350/450/550 SUPERDUTY SUPERCREW
Driver Side Installation Pictured

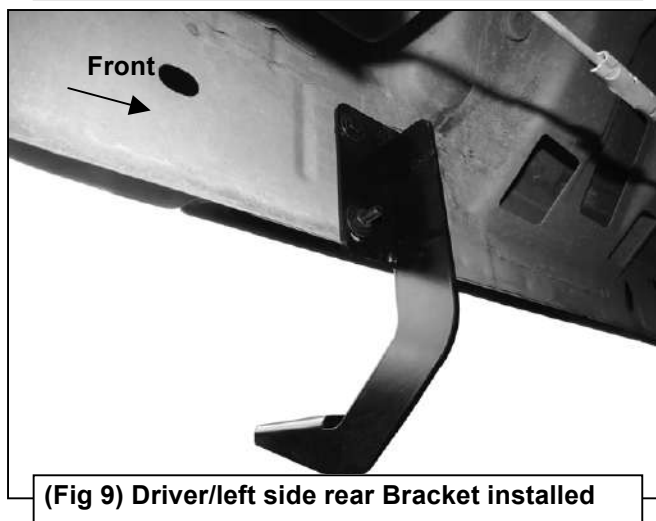
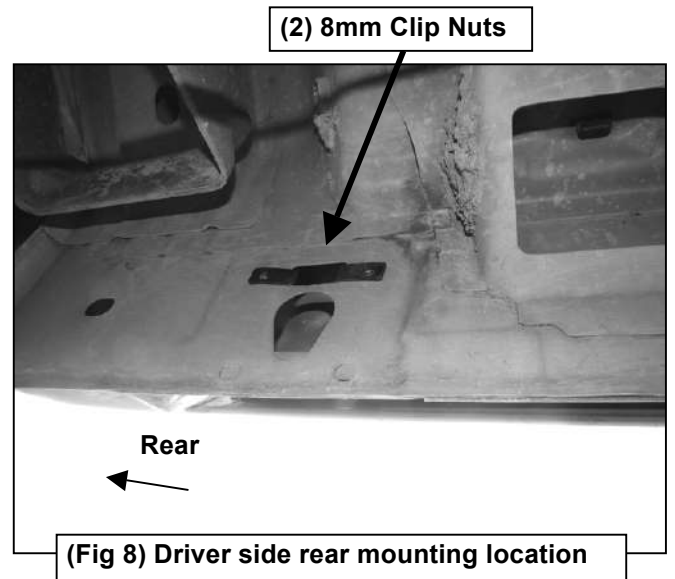
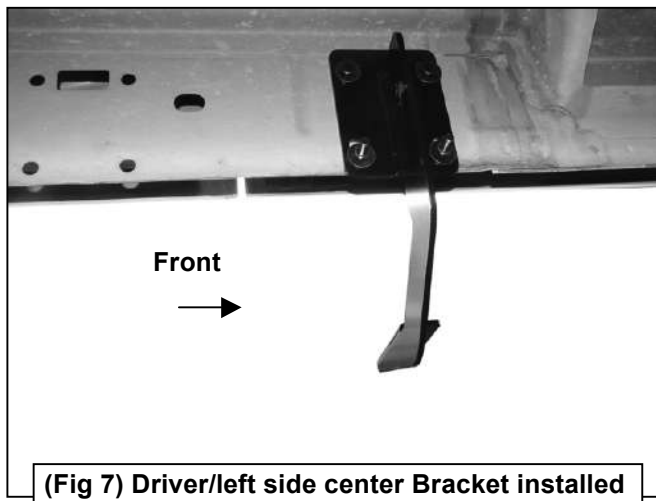
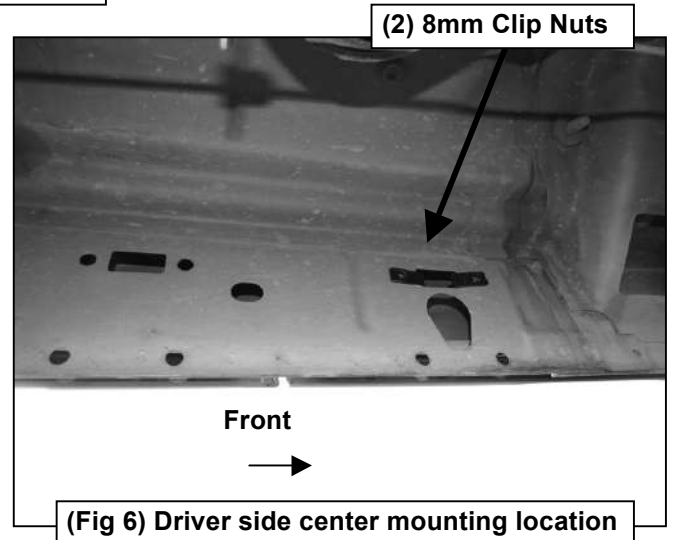
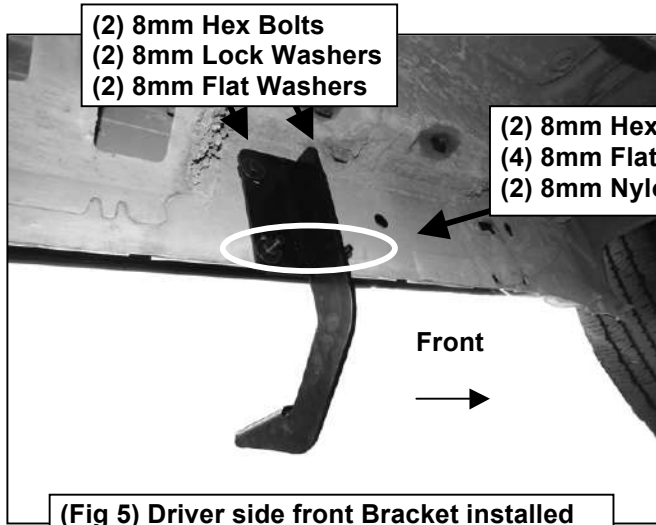

SR2 RUNNING BOARDS
99-16 FORD 250/350/450/550 SUPERDUTY SUPERCREW
Driver Side Installation Pictured

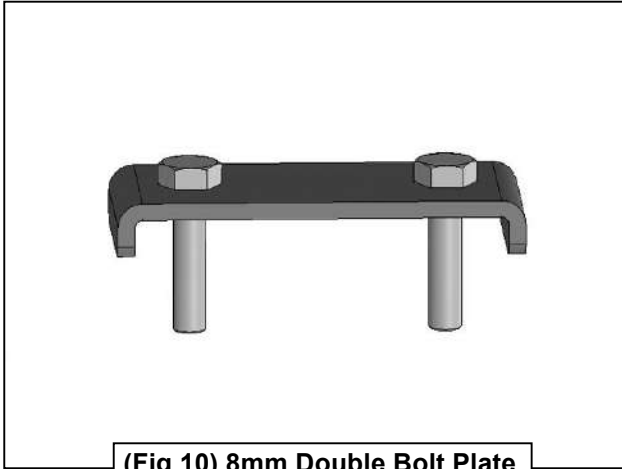

(Fig 10) 8mm Double Bolt Plate

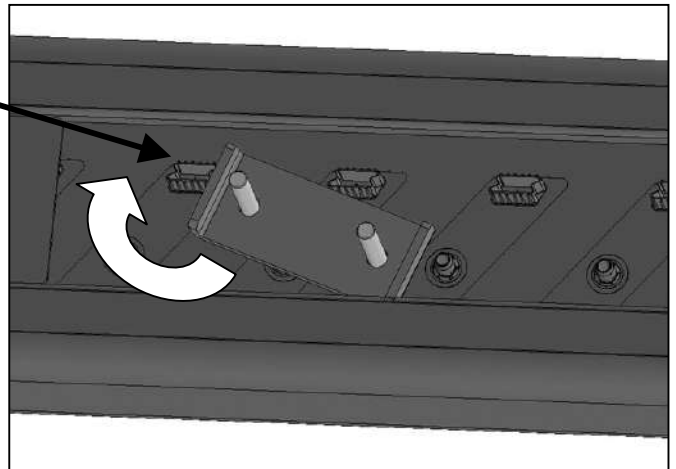

(Fig 11) Slide 8mm Double Bolt Plate into channel

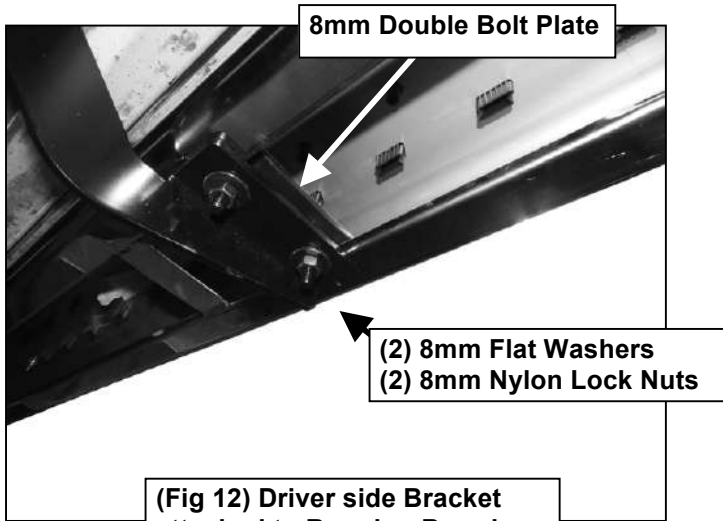

(Fig 12) Driver side Bracket attached to Running Board

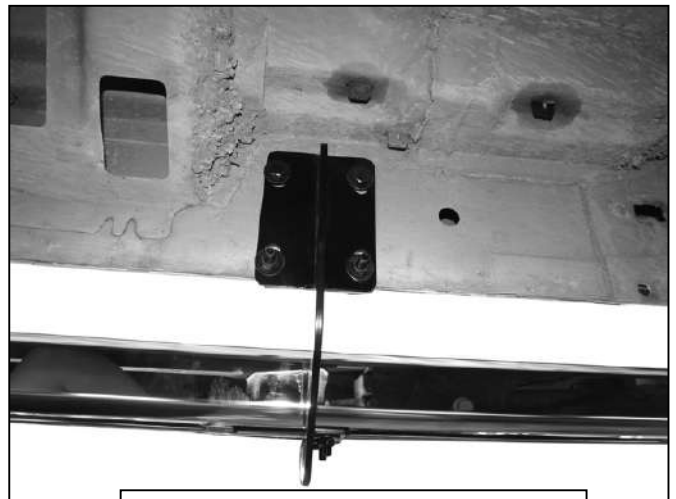

(Fig 13) Driver side front Bracket attached to Running Board

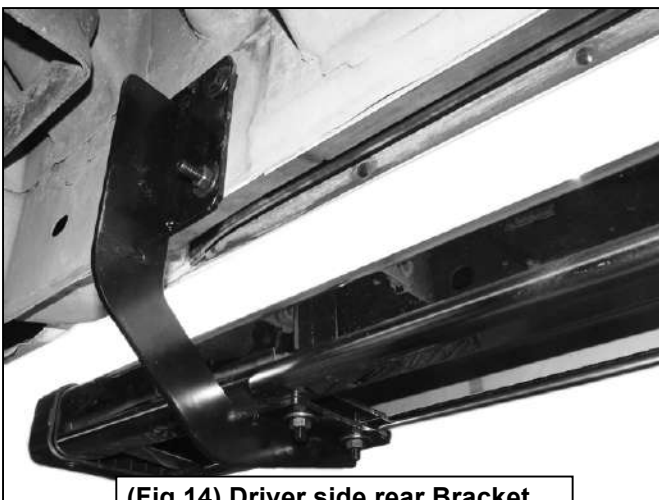

(Fig 14) Driver side rear Bracket attached to Running Board



Complete Installation