

Installation Instructions

I - Sheet Number LUNDSR203

LUND[®]

Premium Style. Lasting Performance.

For proper installation and best possible fit, please read all instructions BEFORE you begin.

Care and Cleaning

- Wash only with mild soap and dry with a clean cloth.
- Every 3 months or 5000 miles check for loose hardware and tighten as necessary.

Congratulations!

You have purchased one of the many quality Lund[®] branded products offered by Lund International, Inc. We take the utmost pride in our products and want you to enjoy years of satisfaction from your investment. We have made every effort to ensure that your product is top quality in terms of fit, durability, finish and ease of installation.

**SR2 RUNNING BOARDS
07-17 TOYOTA TUNDRA CREWMAX**

PARTS LIST:

2	SR2 Running Boards	2	Passenger/Right Rear Mounting Brackets
1	Driver/Left Front Mounting Bracket	8	8mm Double Bolt Plates
1	Passenger/Right Front Mounting Bracket	16	8-1.25 x 30mm Hex Bolts
1	Driver/Left Center Mounting Bracket	32	8mm x 24mm Flat Washers
1	Passenger/Right Center Mounting Bracket	16	8mm Lock Washers
2	Driver/Left Rear Mounting Brackets	16	8-1.25mm Nylon Lock Nuts

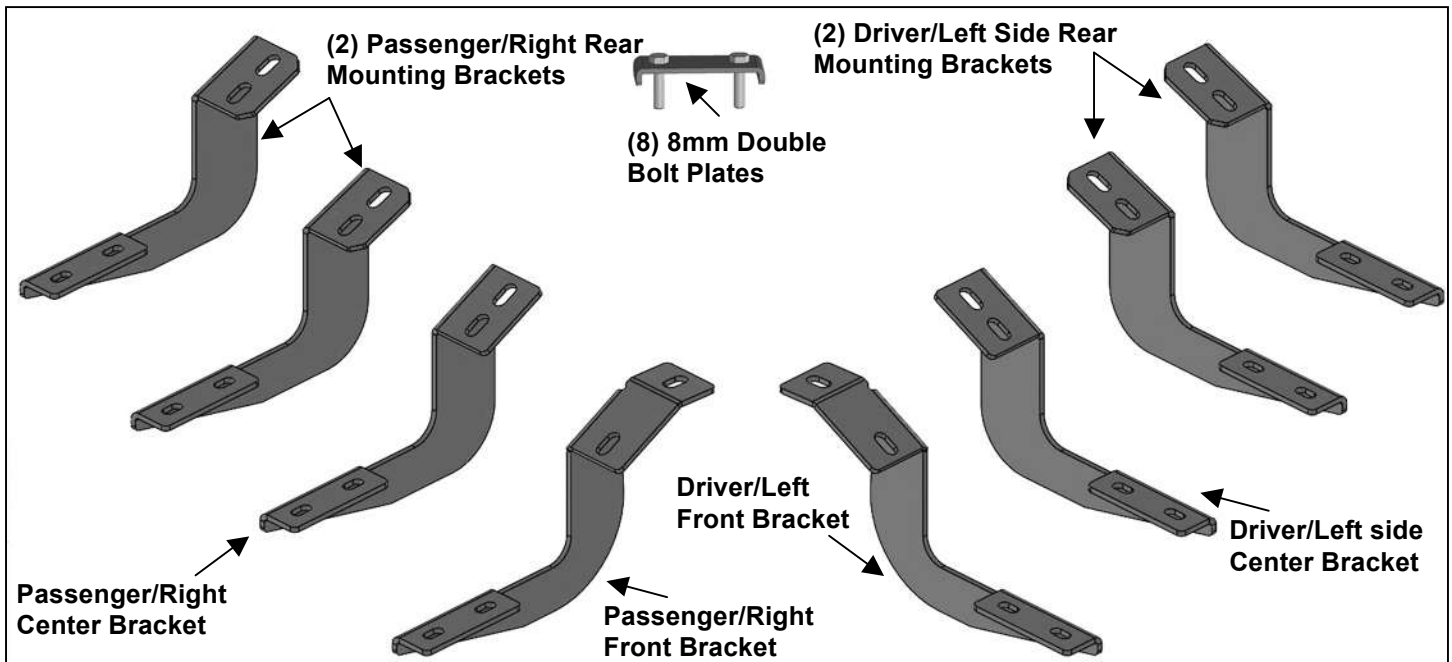

PROCEDURE:

- 1. REMOVE CONTENTS FROM BOX. VERIFY ALL PARTS ARE PRESENT. READ INSTRUCTIONS CAREFULLY. USE ILLUSTRATION TO IDENTIFY BRACKETS AND RUNNING BOARDS.**
- Starting on the passenger side, front of the vehicle, remove the plastic plugs or hex bolts covering the (2) threaded holes in the body panel, **(Figure 1)**. Select the passenger side Front Mounting Bracket, **(Figure 2)**. Attach the Bracket to the vehicle using the included (2) 8mm Hex Bolts, (2) 8mm Lock Washers and (2) 8mm Flat Washers, **(Figure 3)**. Do not tighten hardware at this time.
- Next, move to the 2nd mounting location, **(Figure 5)**. Select the passenger side center Mounting Bracket, **(Figure 4)**. **IMPORTANT:** The Center and Rear Brackets look similar but each one is unique. Use the illustration above and **Figure 4** to help identify each Bracket. Repeat **Step 2** to install the center Mounting Bracket, **(Figures 6 & 7)**.
- Move along to the 3rd mounting location, **(Figures 8)**. Repeat **Step 2** to install (1) Passenger side Rear Mounting Bracket, **(Figure 9)**.
- Continue to the last, 4th, mounting location at the back of the cab, **(Figure 10)**. Repeat **Step 2** to install the passenger side rear Bracket, **(Figure 11)**. When properly installed, the cradles for the Running Board will face toward the front.
- Once all (4) Brackets have been fully installed, carefully unwrap (1) Running Board. Place the Running Board on top of the (4) Brackets. Locate the channels in the bottom of the Running Board. Select (4) 8mm Double Bolt Plates, **(Figure 12)**. Insert the Bolt Plates into the channels in the bottom of the Running Board closest to the Brackets, **(Figure 13)**. Lift the Running Board up and guide the studs down through the Brackets.
- Attach the Running Board to the Mounting Brackets with the included (8) 8mm Flat Washers and (8) 8mm Nylon Lock Nuts, **(Figures 14—17)**. Do not tighten at this time.
- Level and adjust the Running Board as desired and tighten all hardware.
- Repeat **Steps 2—8** for driver side Running Board installation.

**SR2 RUNNING BOARDS
07-17 TOYOTA TUNDRA CREWMAX**

10. Do periodic inspections to the installation to make sure that all hardware is secure and tight.

To protect your investment, wax this product after installing. Regular waxing is recommended to add a protective layer over the finish. Do not use any type of polish or wax that may contain abrasives that could damage the finish. Mild soap may be used to clean the Running Board.

Passenger Side Installation Pictured

Remove plastic plugs or factory hex bolts (if equipped)

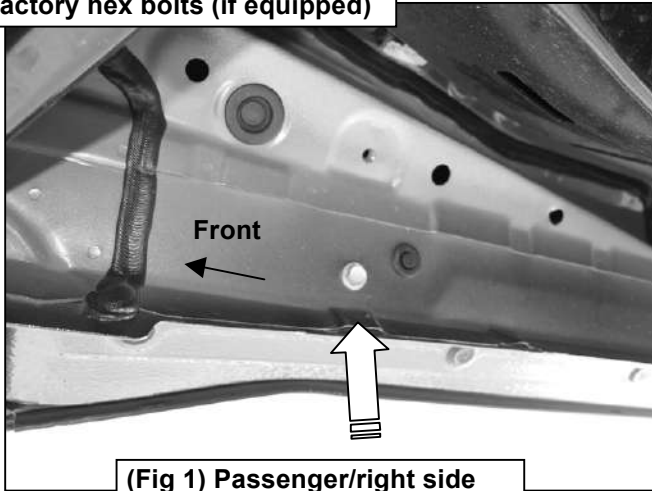

(Fig 1) Passenger/right side front mounting location

(2) 8mm Hex Bolts
(2) 8mm Lock Washers
(2) 8mm Flat Washers

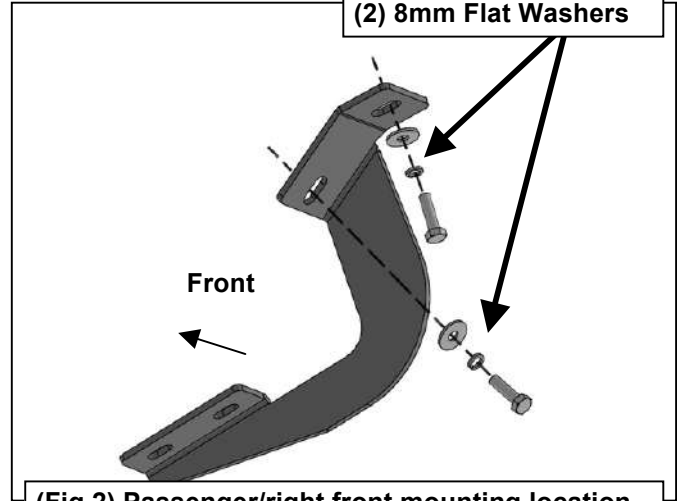

(Fig 2) Passenger/right front mounting location

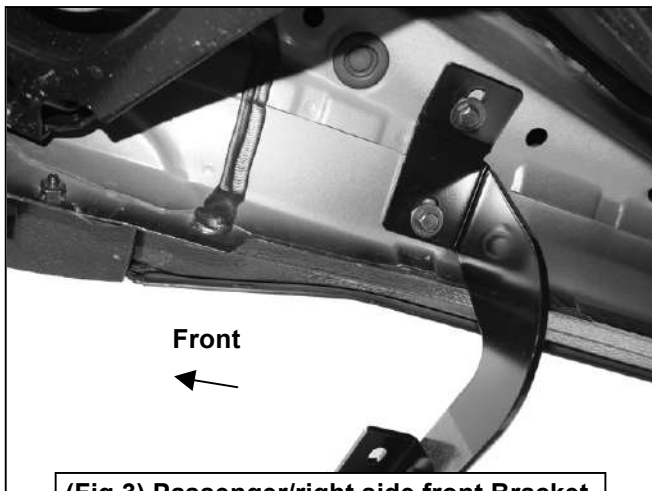

(Fig 3) Passenger/right side front Bracket

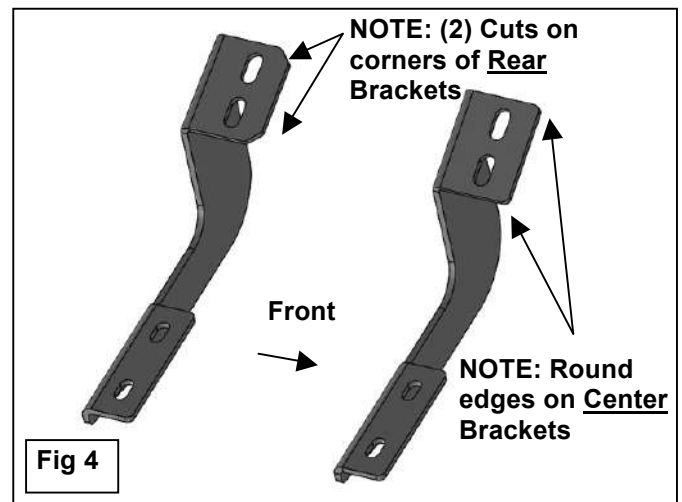
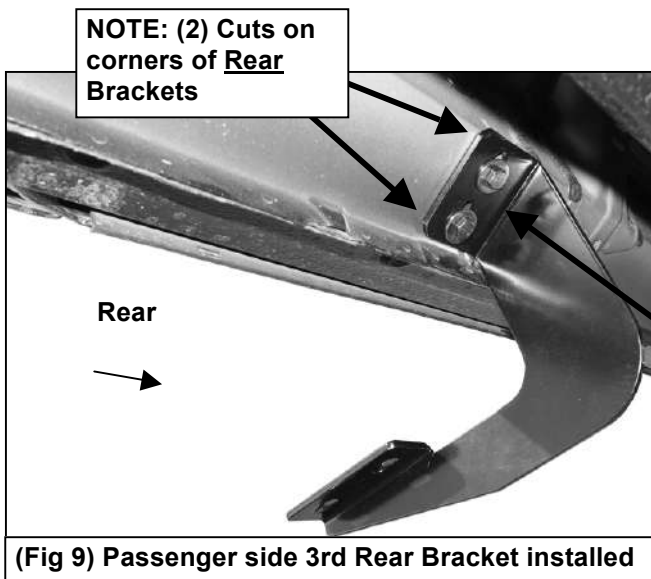
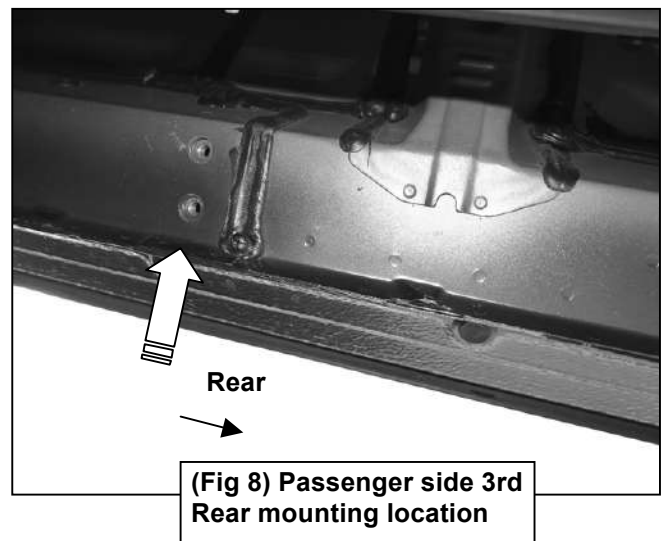
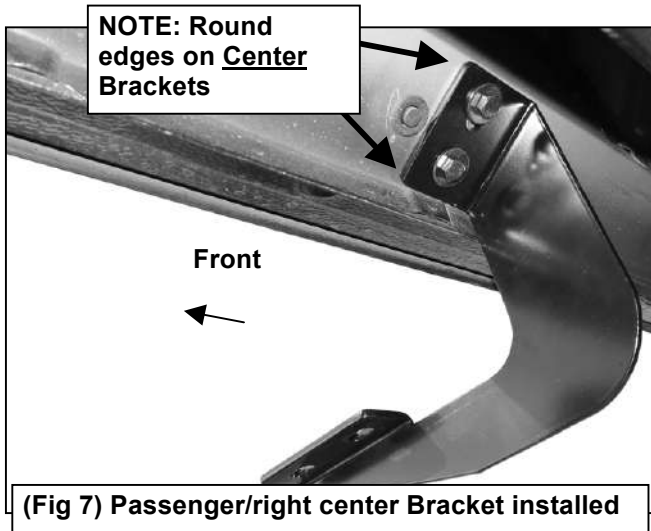
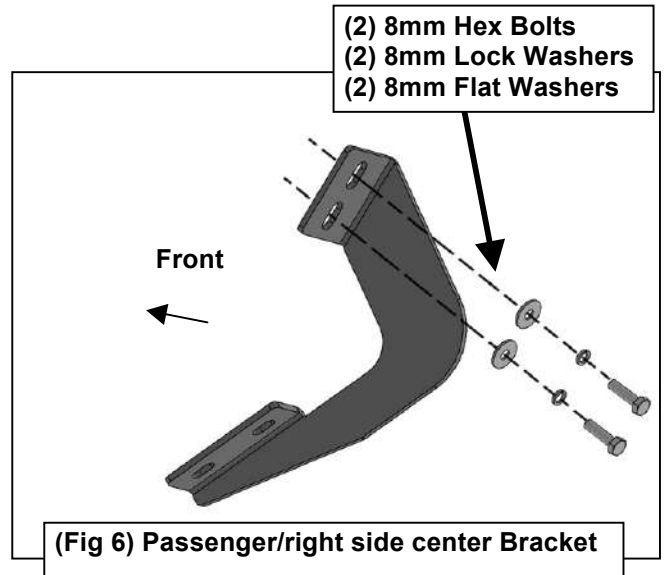
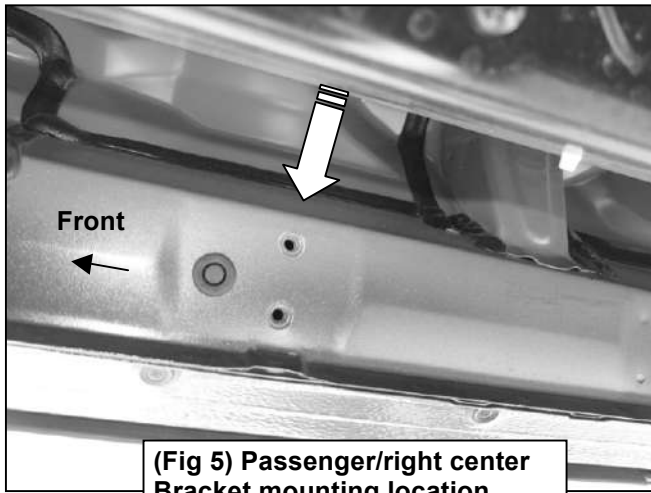

Fig 4

Passenger Side Installation Pictured



(2) 8mm Hex Bolts
(2) 8mm Lock Washers
(2) 8mm Flat Washers

Passenger Side Installation Pictured

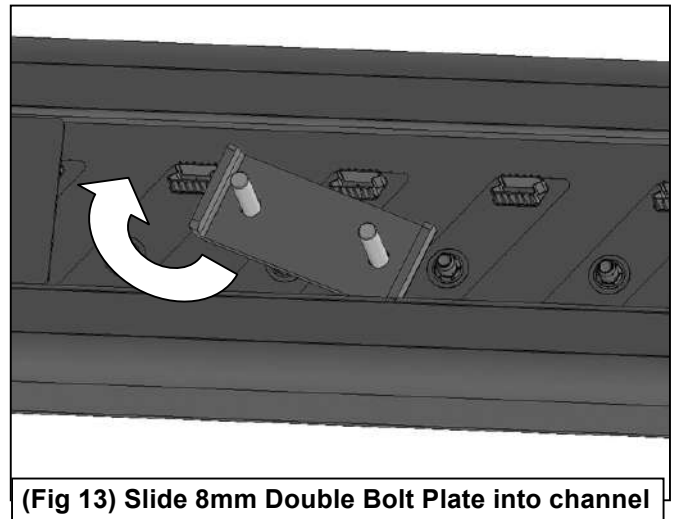
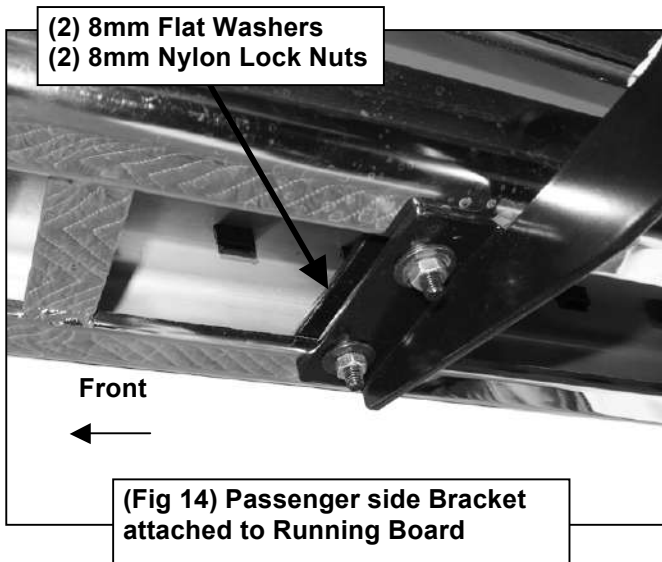
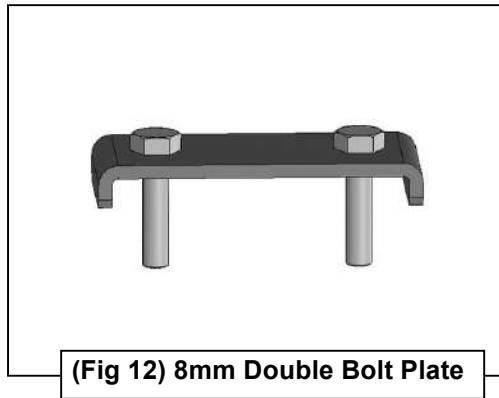
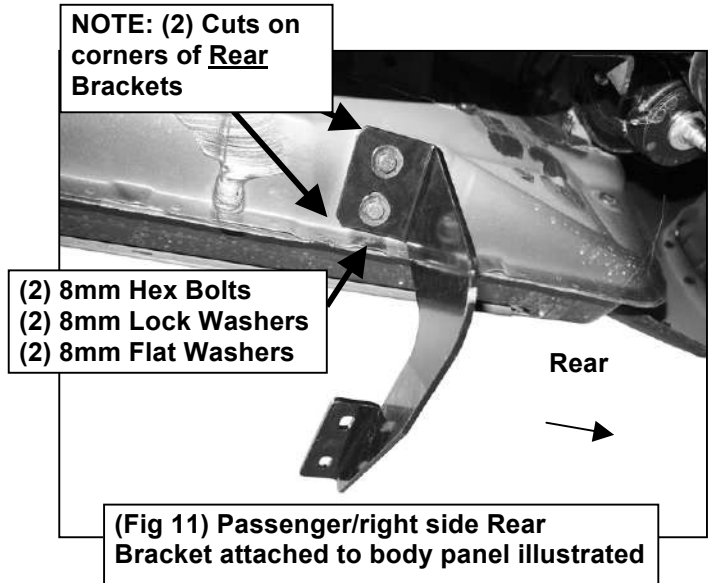
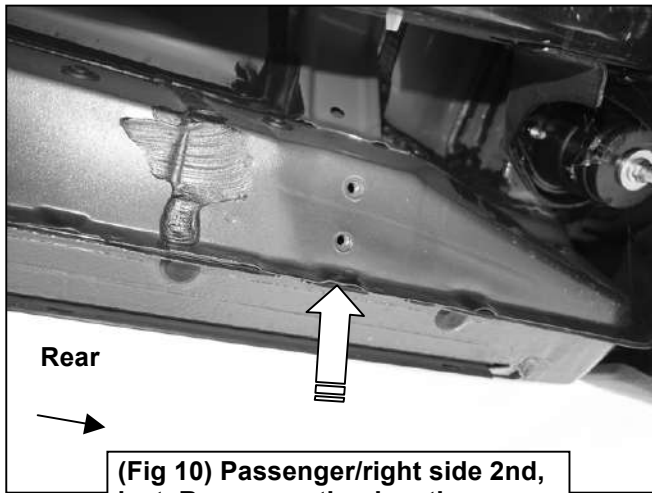

**SR2 RUNNING BOARDS
07-17 TOYOTA TUNDRA CREWMAX**

Passenger Side Installation Pictured

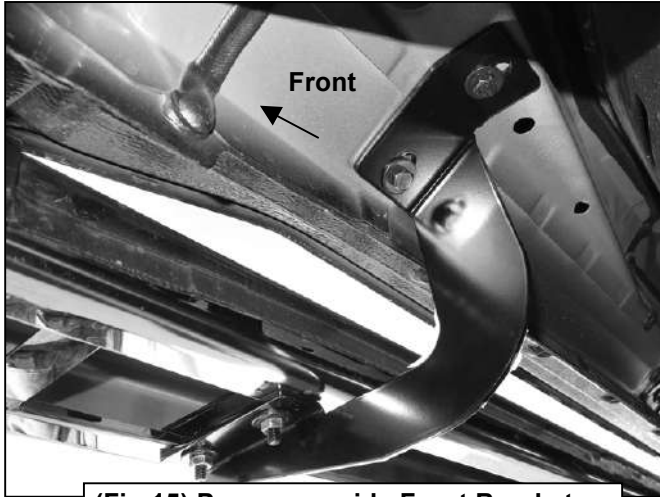

(Fig 15) Passenger side Front Bracket attached to Running Board installed

NOTE: (2) Cuts on corners of Rear Brackets

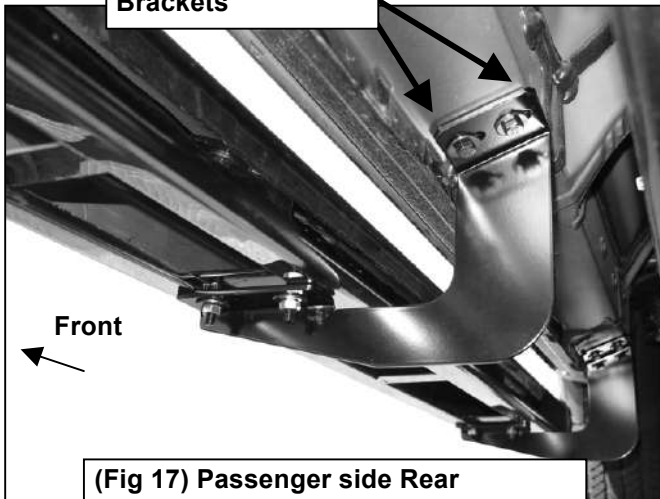

(Fig 17) Passenger side Rear Brackets attached to Running Board

NOTE: Round edges on Center Brackets

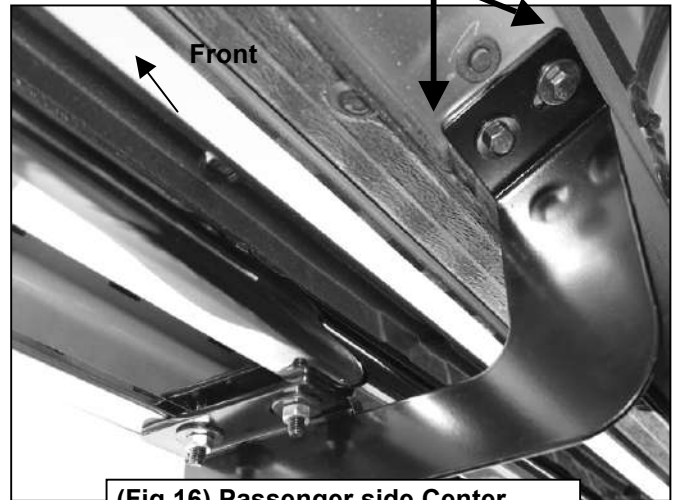

(Fig 16) Passenger side Center Bracket attached to Running Board



Complete Installation