

# Installation Instructions

I - Sheet Number I-B078501



Premium Style. Lasting Performance.

For proper installation and best possible fit, please read all instructions BEFORE you begin.

## Care and Cleaning

- Wash only with mild soap & dry with a clean cloth.
- Every 3 months or 5000 miles check the cover tension and all components for tightness.

## Congratulations!

You have purchased one of the many quality Lund® branded products offered by Lund International, Inc. We take the utmost pride in our products and want you to enjoy years of satisfaction from your investment. We have made every effort to ensure that your product is top quality in terms of fit, durability, finish and ease of installation.

# Installation Instructions

Part # 22693785/ 23093785

## PARTS LIST:

Qty	Description	Qty	Description
1	Driver/Left Sidebar	4	12-1.75mm x 35mm Bolt/10-1.5mm Nut Plates
1	Passenger/Right Sidebar	4	12-1.75mm x 40mm Bolt Plates
1	Driver/Left Front Mounting Bracket	8	12mm x 32mm OD x 3mm Flat Washers
1	Passenger/Right Front Mounting Bracket	8	12mm Lock Washers
1	Driver/Left Front Support Bracket	8	12mm Hex Nuts
1	Passenger/Right Front Support Bracket	8	12mm Plastic Retainers
1	Driver/Left Center Mounting Bracket	8	10-1.50mm x 35mm Hex Bolts
1	Passenger/Right Center Mounting Bracket	4	10mm x 30mm OD x 2.5mm Flat Washers
2	Rear Mounting Brackets	8	10mm x 20mm OD x 2.5mm Flat Washers
1	Driver/Left Rear Support Mounting Bracket	8	10mm Lock Washers
1	Passenger/Right Support Mounting Bracket	4	10mm Hex Nuts
2	Rear Support Strap	2	8-1.25mm x 25mm Hex Bolt
4	1/2" x 2" Hex Bolts	2	8mm x 24mm OD x 2mm Flat Washers
4	1/2" Lock Washers	2	8mm Lock Washers
4	1/2" X 1-1/2" OD x 1/8" Flat Washers		

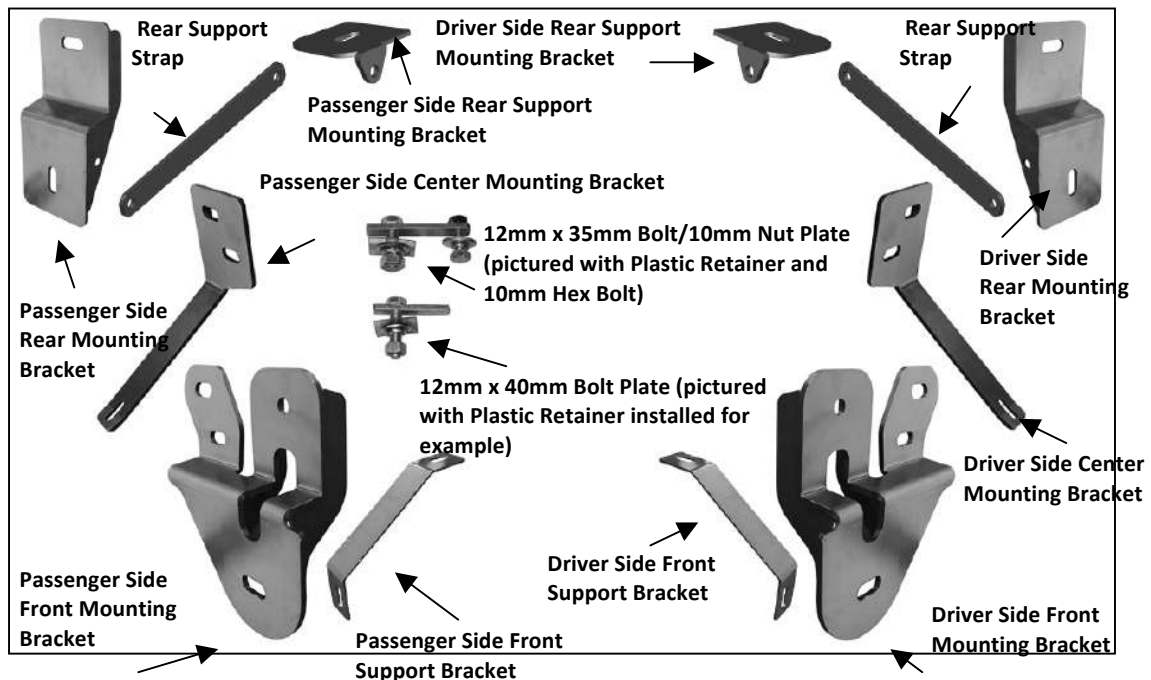

## PROCEDURE:

1. REMOVE CONTENTS FROM BOX. VERIFY ALL PARTS ARE PRESENT. READ INSTRUCTIONS CAREFULLY BEFORE STARTING INSTALLATION.
2. Starting at the driver side-front of the vehicle, remove the tape covering the factory oval holes in the inner body panel located by the front tire. Partially thread a Plastic Retainer onto the threaded end of a Bolt and Nut Plate, (**Fig 1A**). Once you have assembled the Bolt and Nut Plate, insert it into the factory oval hole. Hold the Bolt end with one hand and tighten the Plastic Retainer with your other hand. **NOTE:** Tighten the Plastic Retainer until it is flush against the side panel, (**Figure 2**). **IMPORTANT:** The Plastic Retainer is designed to prevent the Bolt Plate from falling into the body cavity and to aid in mounting the Bracket.

3. Next, select (1) 12mm Bolt Plate and partially thread a Plastic Retainer onto it. Insert the Bolt Plate into the forward, smaller oval hole and install as per Step 2, **(Fig 1B & 2)**.
4. Select the driver side front Mounting Bracket. Position the Mounting Bracket onto the installed Bolt Plates. Secure it with (2) 12mm Flat Washers, (2) 12mm Lock Washers and (2) 12mm Hex Nuts, **(Figure 3)**. Do not tighten at this time. Rotate the Bolt and Nut plate until the threaded nut lines up with the remaining hole in the Mounting Bracket and body. Thread (1) 10mm x 35mm Hex Bolt, (1) 10mm Flat Washer and (1) 10mm Lock Washer into the threaded nut. Do not tighten hardware at this time.
5. Remove the driver side front factory body bolt and washer. Select the driver side Front Support Bracket. Insert the factory body bolt and washer through the slot in the Support Bracket and up into its original position, **(Figure 3)**. Line the other end of the Support Bracket up with the oval hole in the Front Mounting Bracket. Snug but do not tighten hardware.
6. Move to the mid point on the driver side of the vehicle and remove the tape covering the factory oval hole in the inner body panel, **(Figure 4)**. Select and install a Bolt and Nut Plate as described in Step 2, **(Figure 1A, 4)**.
7. Select the driver side Center Mounting Bracket. Position the Mounting Bracket onto the installed Bolt and Nut Plate. Secure it with (1) 12mm Flat Washer, (1) 12mm Lock Washer and (1) 12mm Hex Nut, **(Figure 5)**. Do not tighten at this time. Rotate the Bolt and Nut plate until the Nut end lines up with the remaining hole in the Mounting Bracket and body. Thread (1) 10mm x 35mm Hex Bolt, (1) 10mm Flat Washer and (1) 10mm Lock Washer into the threaded nut. Leave hardware loose at this time.
8. Next, move to the rear mounting location and remove the tape covering the single factory hole. Select (1) 12mm Bolt Plate and install it as described in Steps 2 & 3, **(Figure 6)**. Select the driver side Rear Mounting Bracket. Position the Mounting Bracket onto the installed Bolt Plate. Secure it with (1) 12mm Flat Washer, (1) 12mm Lock Washer and (1) 12mm Hex Nut. Push Bracket up against the body as you tighten the hardware, **(Figure 7)**.
9. Remove the driver side rear factory body bolt and washer. Select the driver side Rear Support Mounting Bracket. Insert the factory body bolt and washer through the Support Mounting Bracket and up into its original position. Next, select (1) Rear Support Strap and bolt it to the mounting tab on the Rear Support Mounting Bracket and to the Rear Mounting Bracket with (2) 10mm x 35mm Hex Bolts, (4) 10mm x 20mm OD Small Flat Washers, (2) 10mm Lock Washers and (2) 10mm Hex Nuts, **(Figure 8)**. Snug but do not tighten hardware at this time.
10. Select the driver Sidebar and with assistance, carefully fasten it to the front and rear Mounting Brackets with the included (2) 1/2" x 2" Hex Head Bolts, (2) 1/2" Lock Washers, and (2) 1/2" Flat Washers, **(Figure 8 & 9)**. Do not tighten at this time.
11. Level and align Sidebar properly; then snug all hardware on the front and rear Mounting Brackets at this time.
12. Line up the Center Mounting Bracket with the threaded insert in the Sidebar. Insert (1) 8mm x 25mm Hex Bolt, (1) 8mm Lock Washer and (1) 8mm Flat Washer through the Center Bracket and into the threaded insert in the Sidebar. Slowly tighten the Mounting Hardware, **(Figure 10)**.
13. Check the Sidebar for level and adjust as necessary. Tighten all hardware at this time.
14. Repeat steps 2-14 for passenger Sidebar installation.
15. Do periodic inspections to the installation to make sure all hardware is secure and tight.

**To protect your investment**, wax this product after installing. Regular waxing is recommended to add a protective layer over the finish. Do not use any type of polish or wax that may contain abrasives that could damage the finish.

**For stainless steel:** Aluminum polish may be used to polish small scratches and scuffs on the finish. Mild soap may be used also to clean the Sidebar.

**For gloss black finishes:** Mild soap may be used to clean the Sidebar.

**DRIVER SIDE INSTALLATION PICTURED**

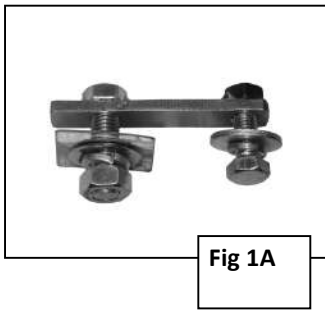

Rotate Bolt and Nut plate to line up Nut with this hole in body panel

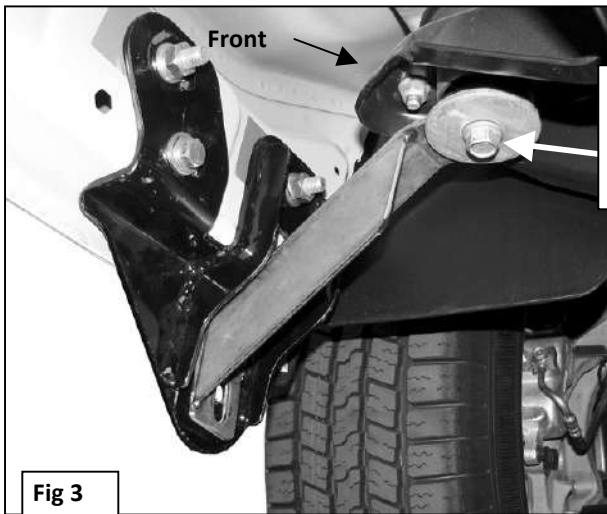
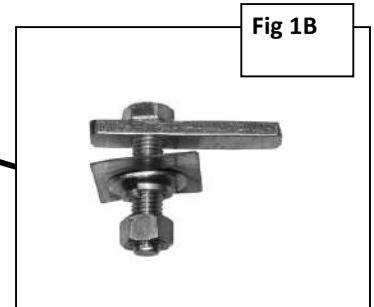
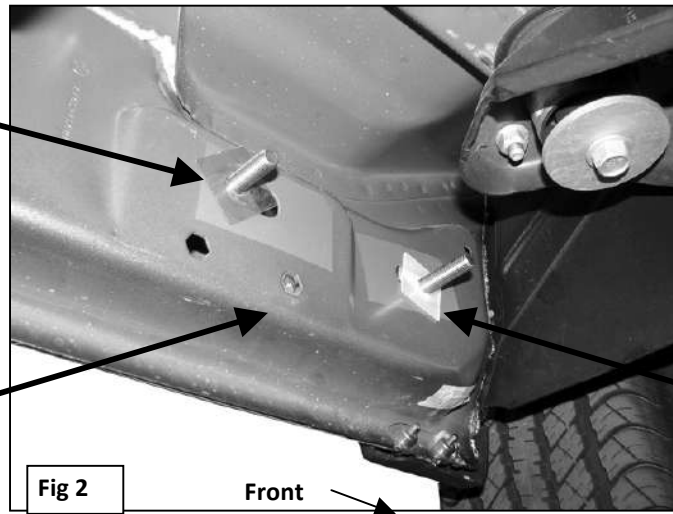

Remove the factory body mount bolt and washer, line up the slot in the driver side Support Bracket and reinstall the factory bolt and washer.

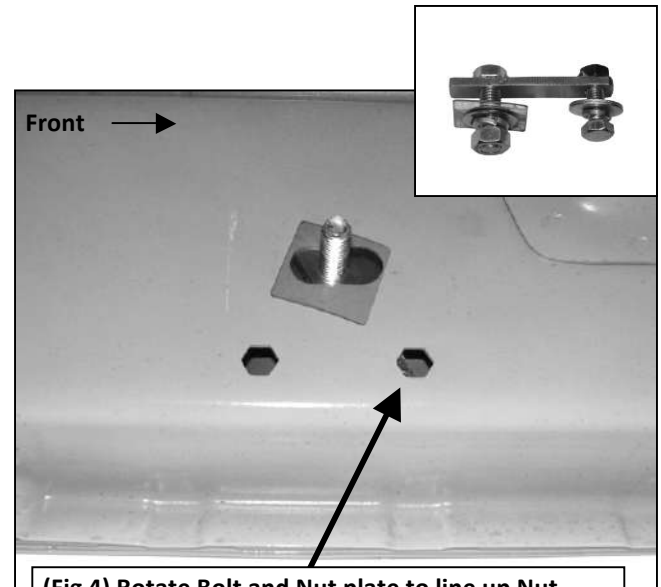

(Fig 4) Rotate Bolt and Nut plate to line up Nut with this hole in body panel. Center Mounting Bracket location pictured.

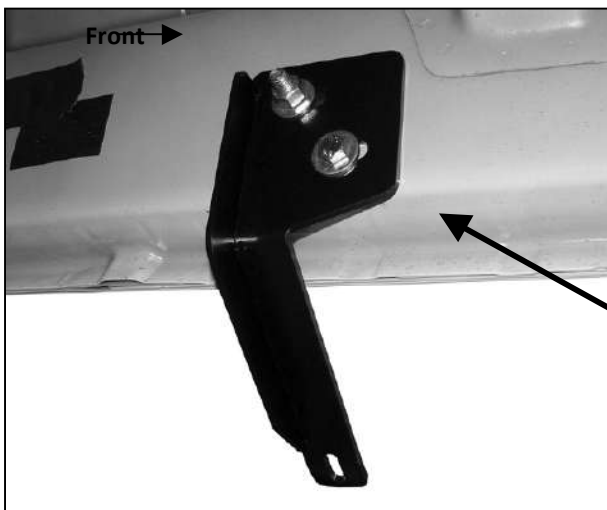

(Fig 5) Center Mounting Bracket pictured

- (1) Bolt and Nut Plate
- (1) 12mm Hex Nut
- (1) 12mm Lock Washer
- (1) 12mm Flat Washer
- (1) 10mm x 35mm Hex Bolt
- (1) 10mm Lock Washer
- (1) 10mm Flat washer

**DRIVER SIDE INSTALLATION PICTURED**

- (1) Bolt Plate w/12mm retainer
- (1) 12mm Lock Washer
- (1) 12mm Flat Washer
- (1) 12mm Hex Nut

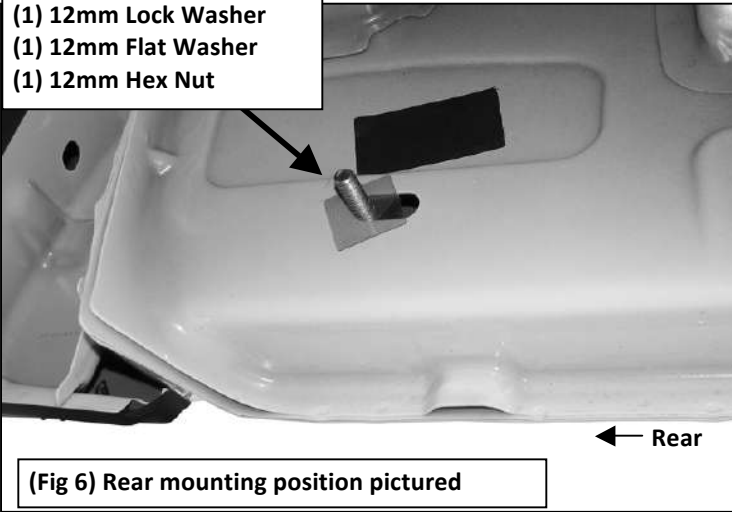

Push rear Mounting Bracket up against the body as you tighten hardware

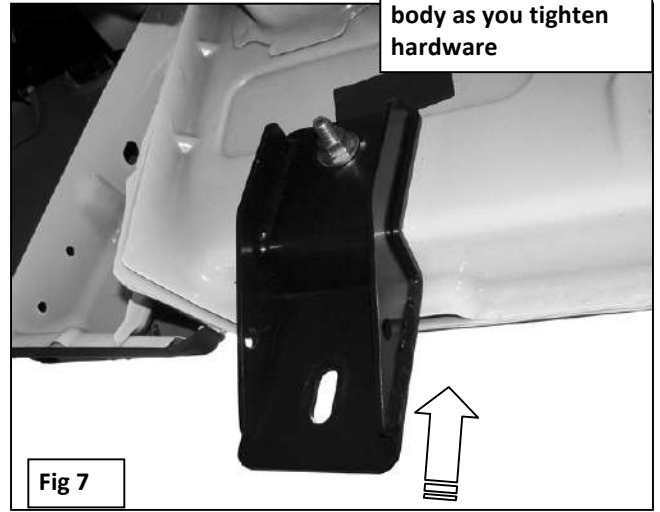

- (2) 10mm x 35mm Hex Bolts
- (2) 10mm Lock Washer
- (4) 10mm x 20mm Flat Washer
- (2) 10mm Hex Nut

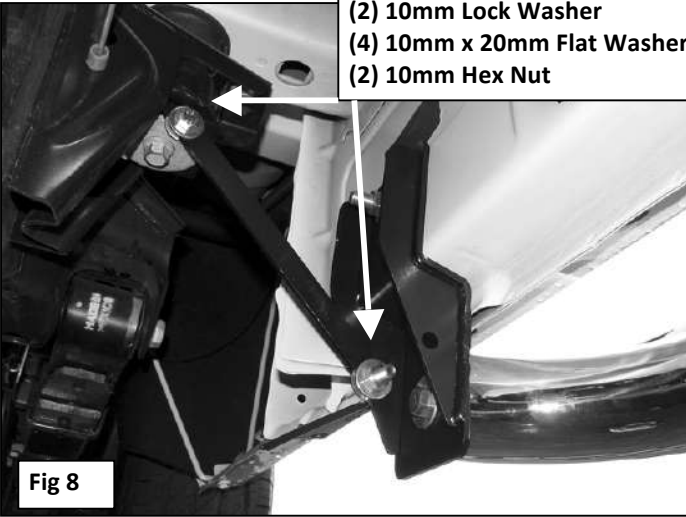

- 8mm x 25mm Hex Bolt
- 8mm Flat Washer
- 8mm Lock Washer

