



Elite Series Fender Flares

For proper installation and best possible fit, please read all instructions BEFORE you begin.

Important Safety Information



- CAUTION - Before driving, ensure that the fender flare is properly secured to vehicle.
- Do not use automatic "brush-style" car washes.
- Do not use cleaning solvents of any kind.
- Periodically check all components for tightness.

Contents **NOTE:** Actual product may vary from illustration.



Driver side front flare



Passenger side front flare



Driver side Side Step



Passenger side Side Step



Driver side rear flare



Passenger side rear flare



Bolts (34)



Spacer (28)



Washer (28)



Nuts (28)



Rubber Seal

Tools Required

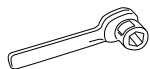

Socket Wrench



Allen Wrench

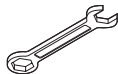

Wrench or Adjustable Wrench



Razor Blade



Needle Nose Pliers



Safety glasses

Preparation Before Painting / Installation

Custom Paint Job (Optional)

Please test fit all the flares first to ensure you have the correct flares for your vehicle. We are not responsible for any costs you may incur if you did not confirm the flares before having it painted. We recommend hiring professionals to custom paint the products. It is also ideal to have the painting done prior to the installation to eliminate any over-spraying issues.

Cleaning the vehicle

Make sure to wash your vehicle, especially the area the fender flares will be mounted to including the inner fender lip after removing the original fender flare and splash guard assembly. Any dirt or debris that has not been cleaned or removed can potentially cause the improper fitment of the fender flare. If you are covering existing rust, we recommend sanding down the rust and primer over to prevent further deterioration of the metal in the fender. Make sure the vehicle is dry before the installation. The fender flares come ready to be installed, however if you need to clean them, please use a mild detergent to wash and then dry completely.

Professional installation (optional)

While every effort has been made to make this installation as simple as possible, professional installation may be advisable in some instances.

Installation Steps NOTE: Actual application may vary slightly from illustrations.

Front Flares

Disengage side marker bulb assembly from side marker lamp housing. Remove mounting nut and remove side marker lamp housing from factory fender flare. Retain mounting nut.

1

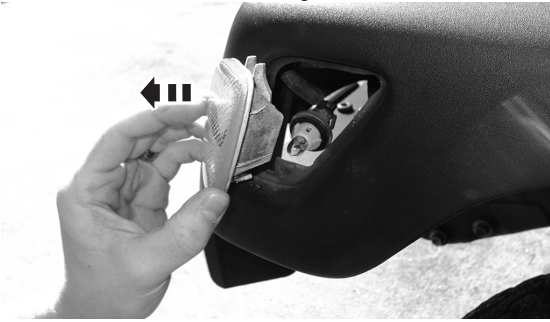

Remove (8) mounting bolts from factory fender flare.

2



Remove front fender flare, and clean fender mounting area.

3



Loosen (3) bolts on factory installed side step, and remove side step. Remove remaining bolts from fender, and clean fender.

4



Use a razor blade to cut and install rubber seal on the new fender flare edge, that will mount against fender.



Place a bolt through a hole in the new fender flare, and place a black spacer on the bolt on the opposite side of the fender flare to retain it in place. Repeat for remaining holes.

5



bolt through this side

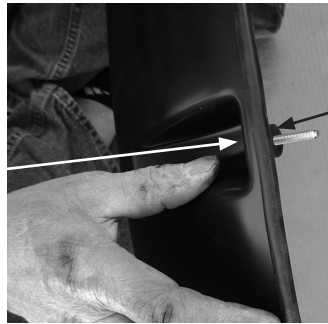

spacer on this side

6

Align new fender flare with holes in fender. NOTE: The new fender flare utilizes (6) holes only.

7



Reach behind the flare and place a washer and nut on each bolt to secure fender flare to fender. DO NOT FULLY TIGHTEN AT THIS TIME.



8



Installation Steps

NOTE: Actual application may vary slightly from illustrations.

With fender flare in final position, tighten all bolts and nuts using hand tools only. **DO NOT OVER TIGHTEN.**

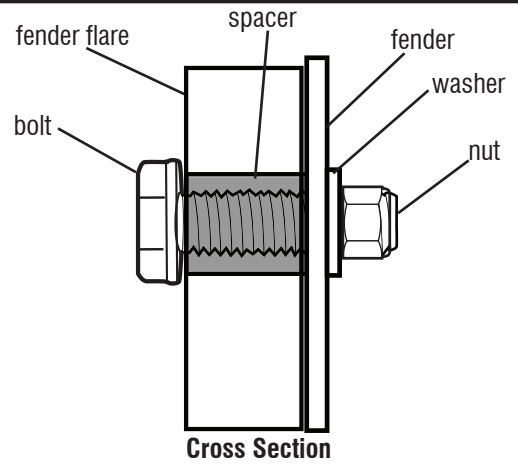

9

Reinstall side marker lamp and bulb assembly.



10



Slide (3) bolts through the new Side Step and thread into mounting holes in fender.



11

With the Side Step in final position, tighten all (3) bolts using hand tools only. **DO NOT OVER TIGHTEN.**



12

Rear Flares

Remove (8) mounting bolts from rear factory fender flare.



13

Remove rear fender flare, and clean fender mounting area.



14

Disengage (2) rubber mounting pins from rear splash shield in order to gain access behind fender.



15

Installation Steps

NOTE: Actual application may vary slightly from illustrations.



Use a razor blade to cut and install rubber trim on the new fender flare edge, that will mount against fender.



16



Place a bolt through a hole in the new fender flare, and place a black spacer on the bolt on the opposite side of the fender flare to retain it in place. Repeat for remaining holes.



bolt through this side

17

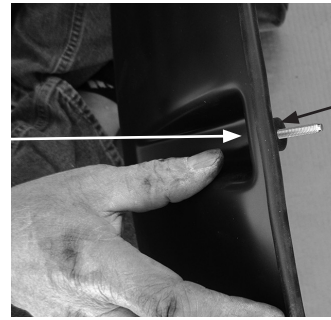

Align new fender flare with holes in fender.



18



19

Reach behind the flare and place a washer and nut on each bolt to secure fender flare to fender. **DO NOT FULLY TIGHTEN AT THIS TIME.**



With fender flare in final position, tighten all bolts and nuts using hand tools only. Reattach splash guard that was loosened in **Step 15**. **DO NOT OVER TIGHTEN.**



20

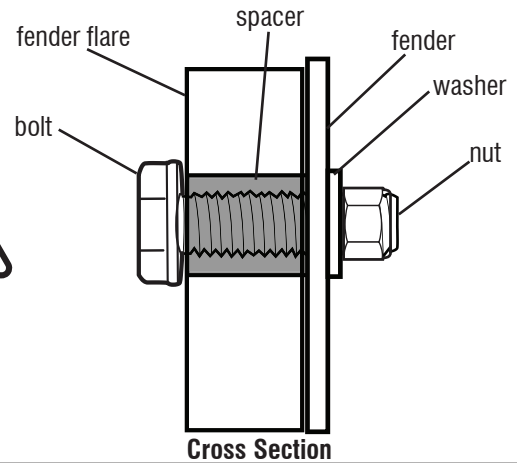

Repeat **Steps 1 thru 20** for opposite side.

Care and Cleaning

- Lund fender flares are built to last; any detergent you use to wash your vehicle is sufficient to clean the flares. Do not use any harsh abrasive detergents.

PLEASE READ: Dirt and debris can become lodged between the fender flares and the vehicle's fenders, causing scratching and paint wear from vibration. Lund International is not responsible for any damage, and the installation of our fender flares is done with the buyer's understanding that this scratching and paint wear may occur.

Congratulations!

You have purchased one of the many quality Lund[®] branded products offered by Lund International, Inc. We take the utmost pride in our products and want you to enjoy years of satisfaction from your investment. We have made every effort to ensure that your product is top quality in terms of fit, durability, finish and ease of installation.



LUND[®]

LUND[®]
INTERNATIONAL