

# DTRL-JLTS9-SPRT

2018+Jeep JL/JT LED Sequential DRL/ Turn Signal Light Instruction Manual

## PRODUCTS PICTURE



## PRODUCT DIMENSIONS

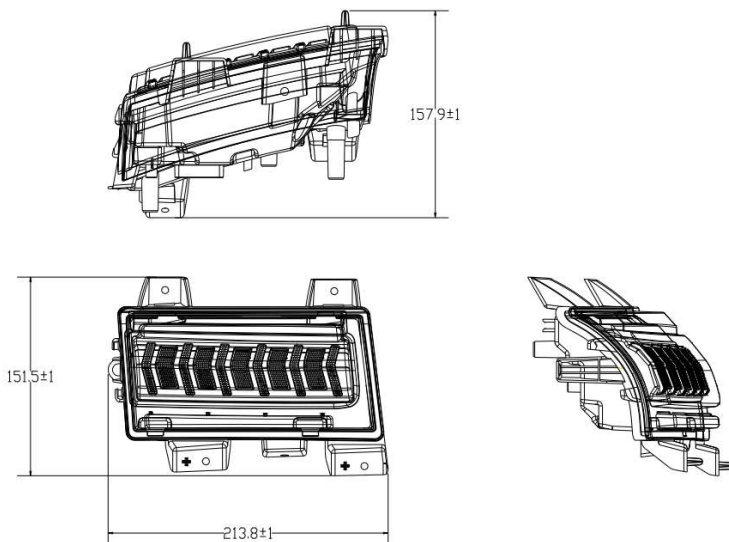

(1) DRL/ Turn Signal

(2) Side Marker Plugs

(3) Resistors Plugs

(4) DRL (Red)

(5) Ground Wire (Black)

(6) Turn Signal (Yellow)

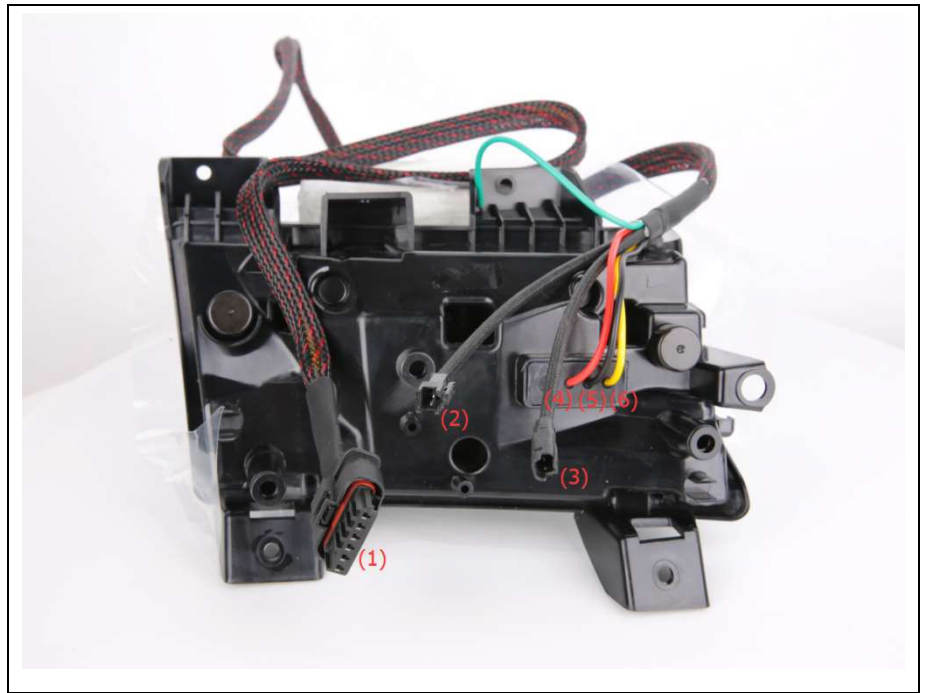

## INSTALLATION INSTRUCTIONS (Examples)

### Pre-Installation Guidelines

1. Read all safety notes and mounting guidelines before installing the product. Verify that all parts listed under “in the box” are present and complete.
2. Verify that all power supply and charging systems comply with the specified voltage limits for the light.
3. Turn off the vehicle and disconnect the battery.

1. Remove the screws and clip inside the fender liner and pull the fender liner down.



2. Lift the entire fender up and away from your Jeep. There are several clips holding it on as you can see from the images below, but you can pull it off with moderate force to safely remove it.



3. Unplug the harness to completely remove the fender.



4. Unscrew the three T25 Torx screws on the bracket behind on the OEM DRL.





5. Remove the ribbed plastic clip on the side of the fender. After this, you can remove the bracket.



6. Remove the T25 Torx screw holding the side marker in place.



7. Remove the two T20 Torx screws at the top of the OEM DRL.



8. Unplug the small 2 pin connector for the OEM Amber side marker. It can then be removed by sliding it forward and away from the DRL/Fender.



9. You will need to pull the OEM DRL off of the fender. There is hidden double-sided tape holding it on from the front side, and it's very strong.



10. Remove the OEM wire harness for the stock DRL that runs to the back of the fender. There are a couple of clips holding it in. Then re-route the harness for the new LED DRL back in the same place.

