



LIMITED SLIP SUPPLEMENT

**For use in all final drives and limited slip posi-traction units.
NOT FOR USE IN AUTOMATIC TRANSMISSIONS**

U.S. PATENT 5,282,989



DESCRIPTION: LUBEGARD® LIMITED SLIP SUPPLEMENT is specifically formulated for the clutches in limited slip differentials. Limited slip differentials depend on the operation of pre-loaded clutch packs on each axle shaft. Gear oils made for standard differentials do not contain the additives that make these clutches work. LUBEGARD® LIMITED SLIP SUPPLEMENT contains patented and synthetic LXE® (liquid wax esters) Technology, an advanced friction modifier to eliminate chatter. It contains rust and corrosion inhibitors to protect bearings and gear surfaces. The LXE® Technology also acts as an enhanced heat transfer component to pull heat out of the gear box and clutches more quickly providing cooler running units. LUBEGARD® LIMITED SLIP SUPPLEMENT benefits all makes of vehicles with limited slip differentials including GM, Ford and Chrysler.

ADDING LUBEGARD® LIMITED SLIP SUPPLEMENT TO A DIFFERENTIAL WILL:

- Universally work in all makes & models with limited slip differentials- Saving Time, Space and Money!
- Eliminate differential chatter, chatter and noise
- Inhibit rust and corrosion
- Reduce differential oil temperatures
- Extend clutch pack and equipment life



FOR USE IN ALL LIMITED SLIP UNITS

DIRECTIONS: Put entire contents of the bottle (4 fl. oz.) into the differential. If necessary, remove enough gear oil to maintain proper level with supplement. Allow 20 miles of road operation for complete mixing.

TYPICAL PROPERTIES:

Specific Gravity, API	0.84
Viscosity Index	193
Flash Point	>450°F
Pour Point	< 0°F



AVAILABILITY:

Stock No.	Unit Size	Case Weight/QNTY
31904	4 oz.	3.22 lbs. (12/case)
31920	4 oz.	4.90 lbs. (12/case)

Note: NOT FOR USE IN AUTOMATIC TRANSMISSIONS!



#31920

Limited Slip Supplement

Superior Friction Modifier Works in ALL Makes & Models including Ford, Chrysler, and GM

LUBEGARD® Limited Slip Supplement is a concentrated friction modifier formulated specifically for eliminating noise and chatter in clutch type limited slip differentials. It can safely be used in all limited slip differentials with either synthetic or petroleum lubricants and replaces manufacturer-recommended friction modifiers.

Limited slip differentials depend on the operation of pre-loaded clutch packs on each axle shaft. Gear oils made for standard differentials do not contain the additives that make these clutches work. LUBEGARD Limited Slip Supplement contains proprietary synthetic LXE® (liquid wax ester) Technology, an advanced friction modifier to eliminate chatter. LXE Technology acts as an enhanced heat transfer component to pull heat out of the gearbox and clutches more quickly providing cooler running units. This formula also contains rust and corrosion inhibitors to protect bearings and gear surfaces.

- » Eliminates differential chatter, groans, squeals and popping
- » Reduces differential oil temperatures
- » Extends clutch pack and equipment life
- » Contains rust and corrosion inhibitors
- » Works for cone or plate type LS differentials

Ask for your free limited slip chart that includes identifications and applications.

TYPICAL TECHNICAL PROPERTIES:

Specific Gravity, API	0.84
Viscosity Index	193
Flashpoint	> 450°F
Pour Point	< 0°F



31904

31921

AVAILABILITY

Stock No.	Unit Size	Case Qty
31904	4 oz	12/c
31921 (display box)	4 oz	12/c
42851 (display box)	4 oz	12/c



42851



LUBEGARD®

THE #1 BRAND

TRUSTED BY MORE
PROFESSIONALS

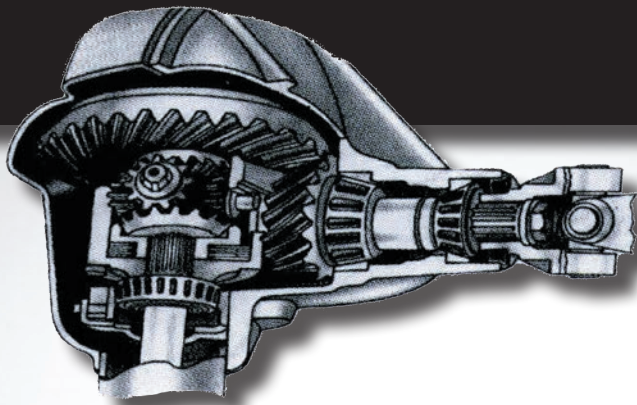

LUBEGARD® Multi-Vehicle Limited Slip Supplement can be used in place of OE friction modifiers (for example Ford, Chrysler, GM, etc) for limited slip differentials.

IMPORTANT! Please be sure to adequately research technical resources such as your vehicle's manual to determine the type of assembly for your application. LUBEGARD Limited Slip Supplement is only for use in clutch-type limited slip differentials.

LIMITED SLIP DIFFERENTIAL

Identification and Application Chart

For use in all clutch-type limited slip differentials

Eliminate differential chatter and noise

Reduce differential oil temperatures

Extend clutch pack and equipment life



Part #42581

THE #1 FRICTION MODIFIER TRUSTED
BY MORE PROFESSIONALS

LUBEGARD #42581
LIMITED SLIP
SUPPLEMENT

- Eliminates noise. No differential chatter, groans, or squeals
- Reduces differential temperatures
- Extends clutch pack and equipment life

WORKS IN ALL MAKES AND MODELS.

CAUTION: EYE IRRITANT.
Read cautions on back panel.

4 FL OZ (118 mL)

IMPORTANT!

How many bottles of LUBEGARD® Limited Slip Supplement is required for your application?



APPLICATION	Year	Rear LS Differential	LG 4 oz. Treat	Front Differential	LG 4 oz. Treat
Buick					
Buick	73-79	GM 8.5" & 8.625"	1	N/A	N/A
Buick Grand National	77-87	GM 8.5" & 8.625"	1	N/A	N/A
Buick Omega	73-79	GM 8.5" & 8.625"	1	N/A	N/A
Buick Regal	73-77	GM 8.5" & 8.625"	1	N/A	N/A

Cadillac

Cadillac	80-90	GM 7.5" & 7.62"	1	N/A	N/A
Cadillac	77-83	GM 8.75" & 8.875"	1	N/A	N/A
Cadillac Fleetwood	77-79	GM 8.75" & 8.875"	1	N/A	N/A
Cadillac Fleetwood Limo	90	GM 8.5" & 8.625"	1	N/A	N/A
Cadillac Seville	77-79	GM 8.5" & 8.625"	1	N/A	N/A

Chevrolet

Chevrolet 1/2 & 3/4 ton Van	79-06	GM 8.5" & 8.625"	1	N/A	N/A
Chevrolet 1/2 ton 4 wd	02-16	GM 8.5" & 8.625"	1	GM 8.25"	1
Chevrolet 1/2 ton truck 2 wd	80-06	GM 8.5" & 8.625"	1	N/A	N/A
Chevrolet 1/2 ton truck 4 wd	80-06	GM 8.5" & 8.625"	1	GM 8.25 & 8.5"	1
Chevrolet 3/4 & 1 ton	73-00	GM 10.5" & 11.5"	2	N/A	N/A
Chevrolet 3/4 & 1 ton Dually	01-10	GM 10.5" & 11.5"	2	GM 8.25" & 9.25"	1
Chevrolet 3/4 ton 2 wd	81-16	GM 9.5"	1	N/A	1
Chevrolet 3/4 ton 4 wd	81-16	GM 9.5"	1	GM 8.25" & 9.25"	1
Chevrolet 3/4 ton C10	07-11	GM 9.5"	1	N/A	N/A
Chevrolet 3/4 ton Van	88-16	GM 9.5"	1	N/A	N/A
Chevrolet Astro C10	03-05	GM 7.5", 7.625" & 8"	1	GM 7.25"	1
Chevrolet Astro Van	99-02	GM 7.5", 7.625" & 8"	1	GM 7.25"	1
Chevrolet Avalanche	99-14	GM 8.5" & 8.625"	1	GM 8.25" & 9.25"	1
Chevrolet Avalanche	99-14	GM 9.5" & 9.75"	1	GM 8.25" & 9.25"	1
Chevrolet Avalanche	99-14	GM 10.5" & 11.5"	2	GM 8.25" & 9.25"	1
Chevrolet C 1500/C 2500 LD/ C 3500 2 wd	99-00	GM 10.5" & 11.5"	2	N/A	N/A
Chevrolet Camaro	82-02	GM 7.5" & 7.62"	1	N/A	N/A
Chevrolet Camaro	67-72	GM 8.2/B.O.P. 8.2"	1	N/A	N/A

DIRECTIONS: Pour entire contents (4 fl. oz.) into the differential. Applications with fluid capacities over 2 quarts will require using an additional 4 ounces. If necessary, remove enough gear oil to maintain proper level with supplement. Allow 20 miles of road operation for complete mixing.

IMPORTANT!

How many bottles of LUBEGARD® Limited Slip Supplement is required for your application?



APPLICATION	Year	Rear LS Differential	LG 4 oz. Treat	Front Differential	LG 4 oz. Treat
Chevrolet Camaro	73-81	GM 8.5" & 8.625"	1	N/A	N/A
Chevrolet Camaro	67-72	GM 12 Bolt	1	N/A	N/A
Chevrolet Camaro V6	10-16	GM 7.625" 10 bolt	1	N/A	N/A
Chevrolet Camaro V8	10-16	GM 8.625 10 bolt	1	N/A	N/A
Chevrolet Caprice	82-90	GM 7.5" & 7.62"	1	N/A	N/A
Chevrolet Caprice/Impala SS	89-96	GM 8.5" & 8.625"	1	N/A	N/A
Chevrolet Caprice PPV	11-15	GM 8.25 10" bolt	1	N/A	N/A
Chevrolet Chevelle	64-72	GM 8.2/B.O.P. 8.2"	1	N/A	N/A
Chevrolet Chevelle	64-72	GM 12 Bolt	1	N/A	N/A
Chevrolet Chevelle	73-77	GM 8.5" & 8.625"	1	N/A	N/A
Chevrolet Colorado 2 wd	04-12	GM 7.5", 7.625" & 8"	1	N/A	N/A
Chevrolet Colorado 2 wd	15-16	GM 7.5", 7.625" & 8"	1	N/A	N/A
Chevrolet Colorado 2 wd	15-16	GM 8.5" & 8.625"	1	N/A	N/A
Chevrolet Colorado 4 wd	04-12	GM 7.5", 7.625" & 8"	1	GM 7.625"	1
Chevrolet Colorado 4 wd	15-16	GM 7.5", 7.625" & 8"	1	GM 7.625"	1
Chevrolet Colorado 4 wd	15-16	GM 8.5" & 8.625"	1	GM 7.625"	1
Chevrolet El Camino	73-75	GM 8.5" & 8.625"	1	N/A	N/A
Chevrolet El Camino	77-88	GM 7.5" & 7.62"	1	N/A	N/A
Chevrolet G & H Series Vans	99-16	GM 9.5" & 9.75"	1	GM 8.25"	1
Chevrolet G & H Series Vans	99-16	GM 10.5" & 11.5"	2	N/A	1
Chevrolet/GMC 1/2 ton 2 wd	64-81	GM 12 Bolt Truck	1	N/A	N/A
Chevrolet/GMC 1/2 ton 4 wd	64-81	GM 12 Bolt Truck	1	GM 7.25"	1
Chevrolet/GMC 1/2 ton Van	70-81	GM 12 Bolt Truck	1	N/A	N/A
Chevrolet Impala	65-68	GM 8.2/B.O.P. 8.2"	1	N/A	N/A
Chevrolet Impala	65-70	GM 12 Bolt	1	N/A	N/A
Chevrolet Impala	82-90	GM 7.5" & 7.62"	1	N/A	N/A
Chevrolet Malibu	77-88	GM 7.5" & 7.62"	1	N/A	N/A
Chevrolet Monte Carlo	64-72	GM 12 Bolt	1	N/A	N/A
Chevrolet Monte Carlo	73-77	GM 8.5" & 8.625"	1	N/A	N/A
Chevrolet Nova	65-72	GM 8.2/B.O.P. 8.2"	1	N/A	N/A
Chevrolet Nova	65-72	GM 12 Bolt	1	N/A	N/A

DIRECTIONS: Pour entire contents (4 fl. oz.) into the differential. Applications with fluid capacities over 2 quarts will require using an additional 4 ounces. If necessary, remove enough gear oil to maintain proper level with supplement. Allow 20 miles of road operation for complete mixing.

IMPORTANT!

How many bottles of LUBEGARD® Limited Slip Supplement is required for your application?



APPLICATION	Year	Rear LS Differential	LG 4 oz. Treat	Front Differential	LG 4 oz. Treat
Chevrolet Nova	73-79	GM 8.5" & 8.625"	1	N/A	N/A
Chevrolet Passenger	55-64	GM 8.2"-55	1	N/A	N/A
Chevrolet S-10 or Blazer 2 wd	88-03	GM 7.5", 7.625" & 8"	1	N/A	N/A
Chevrolet S-10 or Blazer 2wd	82-88	GM 7.5", 7.625" & 8"	1	N/A	N/A
Chevrolet S-10 or Blazer 4 wd	88-04	GM 7.5", 7.625" & 8"	1	GM 7.25"	1
Chevrolet S-10 or Blazer 4wd	82-88	GM 7.5", 7.625" & 8"	1	GM 7.25"	1
Chevrolet S-10 ZR2 4 wd	95-05	GM 8.5" & 8.625"	1	GM 7.25" & 8.25"	1
Chevrolet Silverado HD 2 wd	01-14	GM 8.5" & 8.625"	1	N/A	N/A
Chevrolet Silverado HD 2 wd	01-16	GM 10.5" & 11.5"	2	N/A	N/A
Chevrolet Silverado HD 2 wd	15-16	GM 9.5" & 9.75"	1	N/A	N/A
Chevrolet Silverado HD 4 wd	15-16	GM 9.5" & 9.75"	1	GM 8.25" & 9.25"	1
Chevrolet Silverado HD 4 wd	01-16	GM 10.5" & 11.5"	2	GM 8.25" & 9.25"	1
Chevrolet SS	14-15	GM 8.25 10" bolt	1	N/A	N/A
Chevrolet Suburban/Tahoe 2 wd	01-14	GM 8.5" & 8.625"	1	N/A	N/A
Chevrolet Suburban/Tahoe 2 wd	04-16	GM 9.5" & 9.75"	1	N/A	N/A
Chevrolet Suburban/Tahoe 2 wd	99-16	GM 10.5" & 11.5"	2	N/A	N/A
Chevrolet Suburban/Tahoe 4 wd	00-16	GM 8.5" & 8.625"	1	GM 8.25" & 9.25"	1
Chevrolet Suburban/Tahoe 4 wd	04-16	GM 9.5" & 9.75"	1	GM 8.25" & 9.25"	1
Chevrolet Suburban/Tahoe 4 wd	99-16	GM 10.5" & 11.5"	2	GM 8.25" & 9.25"	1
Chevrolet Trailblazer	03-09	GM 7.5", 7.625" & 8"	1	GM 7.25"	1
Chevy Trailblazer	03-09	GM 8.5" & 8.625"	1	GM 8.25" & 9.25"	1
Chevrolet Trailblazer	05-09	GM 9.5"	1	GM 7.25"	1

Chrysler

Chrysler 300	65-71	Chrysler 8.750" No rear cover, round	1	N/A	N/A
Chrysler Cordoba	80-83	Chrysler 7.5" 10 bolt	1	N/A	N/A
Chrysler Cordoba	75-76	Chrysler 8.25" 10 bolt round cover	1	N/A	N/A
Chrysler Cordoba	75-83	Chrysler 9.25" 12 bolt round cover	1	N/A	N/A
Chrysler Fifth Avenue	88-89	Chrysler 7.5" 10 bolt	1	N/A	N/A
Chrysler Imperial	81-83	Chrysler 7.5" 10 bolt	1	N/A	N/A
Chrysler Imperial	57-73	Chrysler 8.25" 10 bolt round cover	1	N/A	N/A

DIRECTIONS: Pour entire contents (4 fl. oz.) into the differential. Applications with fluid capacities over 2 quarts will require using an additional 4 ounces. If necessary, remove enough gear oil to maintain proper level with supplement. Allow 20 miles of road operation for complete mixing.

IMPORTANT!

How many bottles of LUBEGARD® Limited Slip Supplement is required for your application?



APPLICATION	Year	Rear LS Differential	LG 4 oz. Treat	Front Differential	LG 4 oz. Treat
Chrysler Le Baron	77-81	Chrysler 7.5" 10 bolt	1	N/A	N/A
Chrysler Le Baron Convertible	87-95	Chrysler 7.5" 10 bolt	1	N/A	N/A
Chrysler Le Baron Coupe	87-93	Chrysler 7.5" 10 bolt	1	N/A	N/A
Chrysler New Yorker	82	Chrysler 7.5" 10 bolt	1	N/A	N/A
Chrysler New Yorker	73-76	Chrysler 8.25" 10 bolt round cover	1	N/A	N/A
Chrysler New Yorker	65-78	Chrysler 8.25" 10 bolt round cover	1	N/A	N/A
Chrysler New Yorker	75-82	Chrysler 9.25" 12 bolt round cover	1	N/A	N/A
Chrysler New Yorker Fifth Avenue	82-87	Chrysler 7.5" 10 bolt	1	N/A	N/A
Chrysler Newport	73-76	Chrysler 8.25" 10 bolt round cover	1	N/A	N/A
Chrysler Newport	65-78	Chrysler 8.25" 10 bolt round cover	1	N/A	N/A
Chrysler Newport	75-81	Chrysler 9.25" 12 bolt round cover	1	N/A	N/A

Corvette

Corvette	53-62	C1 Corvette Posi	1	N/A	N/A
Corvette	63-67	C2 Corvette IRS Posi	1	N/A	N/A
Corvette	68-82	C3 Corvette IRS Posi	1	N/A	N/A
Corvette	83-96	C4 Corvette IRS Posi	1	N/A	N/A
Corvette	97-04	C5 Getrag IRS Posi	1	N/A	N/A
Corvette	05-16	C6 Getrag IRS Posi	1	N/A	N/A

Dodge

Dodge 1/2 ton 2 wd	84-93	Chrysler Corp. 9.25" Truck	1	N/A	N/A
Dodge 1/2 ton 4 wd	84-93	Chrysler Corp. 9.25" Truck	1	Dana 60	2
Dodge 100/150 4 wd	74-79	Chrysler Corp. 9.25" Truck	1	Dana 44	1
Dodge 220/330/440	63-64	Chrysler 8.25" 10 bolt round cover	1	N/A	N/A
Dodge A, D and W100/150 2 wd	75-83	Chrysler Corp. 9.25" Truck	1	"	N/A
Dodge A, D and W100/150 4 wd	80-84	Chrysler Corp. 9.25" Truck	1	Dana 44	1
Dodge A-100 Van	64-70	Chrysler Corp. 8.75" Truck	1	N/A	N/A
Dodge Aspen	76-80	Chrysler 7.5" 10 bolt	1	N/A	N/A
Dodge B-100 and 200 Van	71-74	Chrysler Corp. 8.75" Truck	1	N/A	N/A
Dodge B150/B250 Van	82-84	Chrysler Corp. 9.25" Truck	1	N/A	N/A

DIRECTIONS: Pour entire contents (4 fl. oz.) into the differential. Applications with fluid capacities over 2 quarts will require using an additional 4 ounces. If necessary, remove enough gear oil to maintain proper level with supplement. Allow 20 miles of road operation for complete mixing.

IMPORTANT!

How many bottles of LUBEGARD® Limited Slip Supplement is required for your application?



APPLICATION	Year	Rear LS Differential	LG 4 oz. Treat	Front Differential	LG 4 oz. Treat
Dodge B250 Van	92-94	Chrysler Corp. 9.25" Truck	1	N/A	N/A
Dodge B350 Van	84-94	Chrysler Corp. 9.25" Truck	1	N/A	N/A
Dodge BR2500/B3500 Van	95-00	Chrysler Corp. 9.25" Truck	1	N/A	N/A
Dodge Challenger	70-74	Chrysler 8.25" 10 bolt round cover	1	N/A	N/A
Dodge Challenger	15-16	230 MM LS	1	N/A	N/A
Dodge Charger	66-78	Chrysler 8.25" 10 bolt round cover	1	N/A	N/A
Dodge Charger	66-72	Chrysler 9.75" Dana 60 10 bolt cover	2	N/A	N/A
Dodge Charger	73-76	Chrysler 8.25" 10 bolt round cover	1	N/A	N/A
Dodge Charger SRT	08-14	230 MM LS	1	N/A	N/A
Dodge Charger Daytona	69	Chrysler 9.75" Dana 60 10 bolt cover	2	N/A	N/A
Dodge Coronet	65-76	Chrysler 8.25" 10 bolt round cover	1	N/A	N/A
Dodge Coronet	65-71	Chrysler 9.75" Dana 60 10 bolt cover	2	N/A	N/A
Dodge Coronet	73-76	Chrysler 8.25" 10 bolt round cover	1	N/A	N/A
Dodge D100 and W100	58-74	Chrysler Corp. 8.75" Truck	1	N/A	N/A
Dodge Dakota 2wd	87-04	Chrysler Corp. 7.25" Truck	1	N/A	N/A
Dodge Dakota 2wd	99-11	Chrysler Corp. 7.25" Truck	1	N/A	N/A
Dodge Dakota 2wd	99-11	Chrysler Corp. 8.25" Truck	1	N/A	N/A
Dodge Dakota 2wd	99-11	Chrysler Corp. 9.25" Truck	1	N/A	N/A
Dodge Dakota 4wd	87-98	Chrysler Corp. 7.25" Truck	1	Chrysler Corp. 7.25" Truck	1
Dodge Dakota 4wd	99-11	Chrysler Corp. 7.25" Truck	1	C205F	1
Dodge Dakota 4wd	99-11	Chrysler Corp. 8.25" Truck	1	AA 9.25" Truck	1
Dodge Dakota 4wd	99-11	Chrysler Corp. 9.25" Truck	1	Dana 44	1
Dodge Dart	60-62	Chrysler 8.25" 10 bolt round cover	1	N/A	N/A
Dodge Dart	63-76	Chrysler 7.5" 9 bolt	1	N/A	N/A
Dodge Dart	73-76	Chrysler 8.25" 10 bolt round cover	1	N/A	N/A
Dodge Dart Sport	73-76	Chrysler 7.5" 9 bolt	1	N/A	N/A
Dodge Dart Sport	73-76	Chrysler 8.25" 10 bolt round cover	1	N/A	N/A
Dodge Dart Swinger	69-76	Chrysler 7.5" 9 bolt	1	N/A	N/A
Dodge Dart Swinger	73-76	Chrysler 8.25" 10 bolt round cover	1	N/A	N/A

DIRECTIONS: Pour entire contents (4 fl. oz.) into the differential. Applications with fluid capacities over 2 quarts will require using an additional 4 ounces. If necessary, remove enough gear oil to maintain proper level with supplement. Allow 20 miles of road operation for complete mixing.

IMPORTANT!

How many bottles of LUBEGARD® Limited Slip Supplement is required for your application?



APPLICATION	Year	Rear LS Differential	LG 4 oz. Treat	Front Differential	LG 4 oz. Treat
Dodge Demon	71-72	Chrysler 7.5" 9 bolt	1	N/A	N/A
Dodge Diplomat	77-81	Chrysler 7.5" 10 bolt	1	N/A	N/A
Dodge Diplomat	79-89	Chrysler 7.5" 10 bolt	1	N/A	N/A
Dodge Durango	11-13	Aluminum/195 RIA Cast iron/215RII	1	195 FIA	1
Dodge Durango	14-15	Aluminum/230 RIA Cast iron/225RII	1	195 FIA FE	1
Dodge Durango 2 wd	99-11	Chrysler Corp. 7.25" Truck	1	N/A	N/A
Dodge Durango 2 wd	99-11	Chrysler Corp. 8.25" Truck	1	N/A	N/A
Dodge Durango 2 wd	99-11	Chrysler Corp. 9.25" Truck	1	N/A	N/A
Dodge Durango 4 wd	99-11	Chrysler Corp. 7.25" Truck	1	C205F	1
Dodge Durango 4 wd	99-11	Chrysler Corp. 8.25" Truck	1	AA 9.25" Truck	1
Dodge Durango 4 wd	99-11	Chrysler Corp. 9.25" Truck	1	Dana 44	1
Dodge Lancer	61-62	Chrysler 7.5" 9 bolt	1	N/A	N/A
Dodge Mirada	80-83	Chrysler 7.5" 10 bolt	1	N/A	N/A
Dodge Mirada	80-83	Chrysler 9.25" 12 bolt round cover	1	N/A	N/A
Dodge Monaco	73-76	Chrysler 8.25" 10 bolt round cover	1	N/A	N/A
Dodge Polara	62-64	Chrysler 8.25" 10 bolt round cover	1	N/A	N/A
Dodge Power Wagon	42-71	Dana 60	2	Dana 60	2
Dodge Ram 1500	94-02	Dana 60	2	Chrysler Corp. 7.25" Truck	1
Dodge Ram 1500	94-97	Chrysler Corp. 7.25" Truck	1	N/A	N/A
Dodge Ram 1500	94-97	Chrysler Corp. 8.25" Truck	1	N/A	N/A
Dodge Ram 1500	03-07	Chrysler Corp. 9.25" Truck	1	N/A	N/A
Dodge Ram 1500	11-12	Corporate 8.25"/9.25" LS	1	Corporate AA 9.25" LS	1
Dodge Ram 1500	13-16	Corporate 8.25"/9.25" LS	1	Corporate C200FE LS	1
Dodge Ram 1500	13-16	ZF C235 LS	1	ZF 215FD	1
Dodge Ram 1500/2500/3500	08-10	Chrysler AA 11.5" LS	2	9.25" LS	1
Dodge Ram 1500/2500/3500	08-10	Corporate 8.25"/9.25" LS	1	Corporate C200FE LS	1
Dodge Ram 1500/2500/3500	08-10	Dana 226 RBI	1	Dana FBI LS	1
Dodge Ram 2500	94-07	Dana 70	2	Dana 44	1
Dodge Ram 2500	03-07	Chrysler Corp. 7.25" Truck	1	N/A	N/A
Dodge Ram 2500	00-06	Chrysler Corp. 8.25" Truck	1	N/A	N/A

DIRECTIONS: Pour entire contents (4 fl. oz.) into the differential. Applications with fluid capacities over 2 quarts will require using an additional 4 ounces. If necessary, remove enough gear oil to maintain proper level with supplement. Allow 20 miles of road operation for complete mixing.

IMPORTANT!

How many bottles of LUBEGARD® Limited Slip Supplement is required for your application?



APPLICATION	Year	Rear LS Differential	LG 4 oz. Treat	Front Differential	LG 4 oz. Treat
Dodge Ram 2500	94-07	Chrysler Corp. 9.25" Truck	1	N/A	N/A
Dodge Ram 2500	11-12	Chrysler AA 10.5" LS	2	Corporate C200FE LS	1
Dodge Ram 2500/3500	03-07	Chrysler AA 10.5"	1	AA 9.25"	1
Dodge Ram 2500/3500	13-16	Chrysler AA 10.5" LS	1	Dana 216 FBI	1
Dodge Ram 2500/3500	13-16	Chrysler AA 11.5" LS	2	Dana 216 FBI	1
Dodge Ram 3500	94-07	Dana 80	2	Dana 60	2
Dodge Ram 3500	00-02	Chrysler AA 10.5"	1	Dana 60	2
Dodge Ram 3500	03-04	Chrysler AA 11.5" LS	2	Dana 60	2
Dodge Ram 3500	03-07	Chrysler AA 11.5" LS	2	AA 9.25"	1
Dodge Ram 3500	08-10	Chrysler AA 11.5" LS	2	N/A	N/A
Dodge Ram 3500	11-12	Chrysler AA 11.5" LS	2	Dana 216 FBI LS	1
Dodge Ram 3500	11-12	Chrysler AA 11.5" LS	2	ZF C235 LS	1
Dodge Ram 4500/5500	13-16	Corporate C213RE	1	Corporate C200FE LS	1
Dodge Ram 4500/5500	13-16	Dana 310 RBI	3	Magna 275 FBI	3
Dodge Ramcharger W150 4 wd	74-93	Chrysler Corp. 9.25" Truck	1	Dana 60	2
Dodge St. Regis	79-81	Chrysler 9.25" 12 bolt round cover	1	N/A	N/A
Dodge Super Bee	68-71	Chrysler 8.25" 10 bolt round cover	1	N/A	N/A
Dodge Super Bee	66-71	Chrysler 9.75" Dana 60 10 bolt cover	2	N/A	N/A
Dodge Van	85-02	Chrysler Corp. 8.25" Truck	1	N/A	N/A
Dodge Viper	92-10	Viper Unitrax LS Differential	1	N/A	N/A
Dodge Volare	76-80	Chrysler 7.5" 10 bolt	1	N/A	N/A

Ford

Ford Aerostar Van	86-97	Ford 7.5"	1	N/A	N/A
Ford Aerostar Van	86-97	Ford 8.8"	1	N/A	N/A
Ford Bronco 2 wd	83-96	Ford 8.8"	1	N/A	N/A
Ford Bronco 2 wd	66-86	Ford 9"	1	N/A	N/A
Ford Bronco 4 wd	83-96	Ford 8.8"	1	Ford 8.8"	1
Ford Bronco 4 wd	66-71	Ford 9"	!	Dana 30	1
Ford Bronco 4 wd	72-96	Ford 9"	1	Dana 44	1
Ford Bronco II 2 wd	82-90	Ford 7.5"	1	N/A	N/A

IMPORTANT!

How many bottles of LUBEGARD® Limited Slip Supplement is required for your application?



APPLICATION	Year	Rear LS Differential	LG 4 oz. Treat	Front Differential	LG 4 oz. Treat
Ford Bronco II 4 wd	82-91	Ford 7.5"	1	Dana 28	1
Ford Crown Victoria	99-11	Ford 8.8"	1	N/A	N/A
Ford E-150 2 wd	97-16	Ford 9.75"	1	N/A	N/A
Ford E-150 4 wd	97-16	Ford 9.75"	1	Ford 8.8"	1
Ford E-350	07-16	Dana 60	2	N/A	N/A
Ford E-350	06-16	Dana 70	2	N/A	N/A
Ford Econoline	87-06	Ford 8.8"	1	N/A	N/A
Ford Excursion	00-05	Ford Sterling 10.5"	2	Dana 60	2
Ford Expedition 2 wd	97-03	Ford 8.8"	1	N/A	N/A
Ford Expedition 2 wd	97-08	Ford 9.75"	1	N/A	N/A
Ford Expedition 4 wd	97-03	Ford 8.8"	1	Ford 8.8"	1
Ford Expedition 4 wd	97-08	Ford 9.75"	1	Dana 35	N/A
Ford Explorer 2 wd	91-01	Ford 8.8"	1	N/A	N/A
Ford Explorer 4 wd	91-01	Ford 8.8"	1	Dana 35	1
Ford F-150 2 wd	83-96	Ford 8.8"	1	N/A	N/A
Ford F-150 2 wd	96-16	Ford 8.8"	1	N/A	N/A
Ford F-150 2 wd	74-86	Ford 9"	1	N/A	N/A
Ford F-150 2 wd	97-08	Ford 9.75"	1	N/A	N/A
Ford F-150 4 wd	83-96	Ford 8.8"	1	Dana 44	1
Ford F-150 4 wd	96-16	Ford 8.8"	1	Ford 8.8"	1
Ford F-150 4 wd	74-86	Ford 9"	1	Dana 44	1
Ford F-150 4 wd	97-08	Ford 9.75"	1	Dana 35	1
Ford F-250 2 wd	86-97	Ford Sterling 10.25"	1	N/A	N/A
Ford F-250 4 wd	86-97	Ford Sterling 10.25"	1	Dana 60	2
Ford F-250/F-350	99-01	Ford Sterling 10.5"	2	Dana 50	1
Ford F-250/F-350	07-16	Ford Sterling 10.5"	2	Dana 60	2
Ford F-350/F-450/F-550	06-16	Dana 80	2	Dana 60	2
Ford F-350/F-450/F-550	02-16	Dana S110/S130	3	Dana 60	1
Ford F-450/F-550	02-06	Ford Sterling 10.5"	2	Dana 60	2
Ford F-450/F-550	99-06	Dana 135	6	Dana 60	1
Ford Granada	79-89	Ford 7.5"	1	N/A	N/A

IMPORTANT!

How many bottles of LUBEGARD® Limited Slip Supplement is required for your application?



APPLICATION	Year	Rear LS Differential	LG 4 oz. Treat	Front Differential	LG 4 oz. Treat
Ford Granada	79-89	Ford 8.8"	1	N/A	N/A
Ford LTD	78-89	Ford 7.5"	1	N/A	N/A
Ford LTD	78-89	Ford 8.8"	1	N/A	N/A
Ford Mustang	79-10	Ford 7.5"	1	N/A	N/A
Ford Mustang	79-16	Ford 8.8"	1	N/A	N/A
Ford Mustang	65-72	Ford 8" & 9"	1	N/A	N/A
Ford Police/Lemo	02-11	Ford 8.8"	1	N/A	N/A
Ford Ranger 2 wd	90-11	Ford 7.5"	1	N/A	N/A
Ford Ranger 2 wd	90-06	Ford 8.8"	1	N/A	N/A
Ford Ranger 4 wd	90-11	Ford 7.5"	1	Dana 35	1
Ford Ranger 4 wd	90-06	Ford 8.8"	1	Dana 35	1
Ford Thunderbird	78-88	Ford 7.5"	1	N/A	N/A

GMC

GMC 1/2 ton 4 wd	02-16	GM 8.5" & 8.625"	1	GM 8.25"	1
GMC 3/4 & 1 ton	73-00	GM 10.5" & 11.5"	2	N/A	N/A
GMC 3/4 & 1 ton Dually	01-10	GM 10.5" & 11.5"	2	GM 8.25" & 9.25"	1
GMC 1/2 ton truck 2 wd	80-06	GM 8.5" & 8.625"	1	N/A	N/A
GMC 3/4 ton 4 wd	81-16	GM 9.5"	1	GM 8.25" & 9.25"	1
GMC 3/4 ton Van	88-16	GM 9.5"	1	N/A	N/A
GMC Canyon 2 wd	15-16	GM 7.5", 7.625" & 8"	1	N/A	N/A
GMC Sierra HD	01-16	GM 10.5" & 11.5"	2	GM 8.25" & 9.25"	1
GMC 3/4 ton 2 wd	81-16	GM 9.5"	1	N/A	N/A
GMC Canyon 2 wd	04-12	GM 7.5", 7.625" & 8"	1	N/A	N/A
GMC Canyon 2 wd	15-16	GM 8.5" & 8.625"	1	N/A	N/A
GMC Canyon 4 wd	04-12	GM 7.5", 7.625" & 8"	1	GM 7.625"	1
GMC Canyon 4 wd	15-16	GM 7.5", 7.625" & 8"	1	GM 7.625"	1
GMC Canyon 4 wd	15-16	GM 8.5" & 8.625"	1	GM 7.625"	1
GMC Envoy	03-09	GM 7.5", 7.625" & 8"	1	GM 7.25"	1
GMC Envoy	03-09	GM 8.5" & 8.625"	1	GM 8.25" & 9.25"	1
GMC Envoy	05-09	GM 9.5"	1	GM 7.25"	1
GMC Safari Van	99-05	GM 7.5", 7.625" & 8"	1	GM 7.25"	1

DIRECTIONS: Pour entire contents (4 fl. oz.) into the differential. Applications with fluid capacities over 2 quarts will require using an additional 4 ounces. If necessary, remove enough gear oil to maintain proper level with supplement. Allow 20 miles of road operation for complete mixing.

IMPORTANT!

How many bottles of LUBEGARD® Limited Slip Supplement is required for your application?



APPLICATION	Year	Rear LS Differential	LG 4 oz. Treat	Front Differential	LG 4 oz. Treat
GMC Sonoma	01-04	GM 7.5", 7.625" & 8"	1	GM 7.25"	1
GMC Yukon	00-16	GM 8.5" & 8.625"	1	GM 8.25" & 9.25"	1
GMC Yukon	00-16	GM 9.5" & 9.75"	1	GM 8.25" & 9.25"	1
GMC Yukon	00-16	GM 10.5" & 11.5"	2	GM 8.25" & 9.25"	1

Hummer

H2	03-07	GM 9.5"	1	GM 9.25"	1
H2	03-09	GM 8.625"	1	GM 9.25"	1
H3	06-10	GM 8.625"	1	GM 7.625"	1
H3	06-10	GM 8.5" & 8.625"	1	GM 8.25" & 9.25"	1
H3T	06-10	GM 8.625"	1	GM 7.625"	1

Hyundai

Santa Fe	01-10	SUV differential	1	N/A	N/A
Tucson	05-00	SUV differential	1	N/A	N/A
Vera Cruz	07-10	SUV differential	1	N/A	N/A

Isuzu

Trooper	99-02	Isuzu SUV differential	1	Isuzu Front Differential	1
VehiCROSS	99-01	Isuzu SUV differential	1	Isuzu Front Differential	1

Jeep

Cherokee	99-01	4 cyl/194 RBI diff. 6cyl/8.25" diff.	1	4 cyl/181 diff. 6 cyl/186 diff.	1
CJ 5	69-75	Dana 44 (10 bolt cover)	1	Dana 30	1
CJ 5	76-82	AMC 20 (12 bolt cover)	1	Dana 30	1
CJ 7	86	Dana 44 (10 bolt cover)	1	Dana 30	1
CJ 7-8	76-86	AMC 20 (12 bolt cover)	1	Dana 30	1
Grand Cherokee	01-04	194 RBI/198 RBI/ 216/226 RBI	1	186 FBI (Dana 30) C200FE	1
Grand Cherokee	05	C213R	1	186 FBI (Dana 30) C200FE	1
Grand Cherokee	11-15	C213RE	1	C200FE	1
Grand Cherokee / Commander	06-07	C213R/ C213RC	1	186 FBI (Dana 30) C200FE	1
Grand Cherokee / Commander	08-10	C213R/ C213RE	1	C200FE	1
Rubicon	03-06	Dana 44 (locker)	1	Dana 44 (locker)	1
TJ	97-01	Dana 35 (oval cover)	1	Dana 30	1

DIRECTIONS: Pour entire contents (4 fl. oz.) into the differential. Applications with fluid capacities over 2 quarts will require using an additional 4 ounces. If necessary, remove enough gear oil to maintain proper level with supplement. Allow 20 miles of road operation for complete mixing.

IMPORTANT!

How many bottles of LUBEGARD® Limited Slip Supplement is required for your application?



APPLICATION	Year	Rear LS Differential	LG 4 oz. Treat	Front Differential	LG 4 oz. Treat
TJ	99-01	Dana 44 (irregular cover)	1	Dana 30	1
TJ	01-06	194 RBI (Dana 35) 216 RBI (Dana 44)	1	181 FBI (Dana 30)	1
Wrangler	01-06	194 RBI (Dana 35) 216 RBI (Dana 44)	1	181 FBI (Dana 30)	1
Wrangler	03-06	198 RBI (Dana 35) 226 RBI (Dana 44)	1	216 RBI (Dana 44)	1
Wrangler	07-11	198 RBI (Dana 35) 226 RBI (Dana 44)	1	186 FBI (Dana 30)	1
Wrangler	12-16	226 RBI (Dana 44)	1	186 FBI (Dana 30)	1
Wrangler (TJ in Canada)	99-00	4 cyl/194 RBI diff. 6cyl/216 RBI diff.	1	4 cyl/181 diff. 6 cyl/216 diff.	1
XJ	85-96	Dana 35 (oval cover)	1	Dana 30	1
XJ	87-89	Dana 44 (irregular cover)	1	Dana 30	1
XJ	91-05	Chrysler 8.25" LS	1	Dana 30	1
YJ	87-95	Dana 35 (oval cover)	1	Dana 30	1
ZJ (Grand)	92-96	Dana 35 (oval cover)	1	Dana 30	1
ZJ (Grand)	97-99	Dana 44 (irregular cover)	1	Dana 30	1
ZJ (Grand)	97-99	Chrysler 8.25" LS	1	Dana 30	1

Lexus

GX 460	11-16	8.75" LS Differential	1	8" Rev IFS	1
GX 470	03-09	8.75" LS Differential	1	8" Rev IFS	1

Lincoln

Lincoln	92-11	Ford 8.8"	1	N/A	N/A
Lincoln Aviator	03-05	Ford 8.8"	1	Dana 35	1
Lincoln Limo	91-02	Ford 8.8"	1	N/A	N/A
Lincoln Limo	04-15	Ford 8.8"	1	N/A	N/A
Lincoln Town Car	99-11	Ford 8.8"	1	N/A	N/A

Mercury

Mercury	79-93	Ford 7.5"	1	N/A	N/A
Mercury Capri	79-93	Ford 7.5"	1	N/A	N/A
Mercury Cougar	78-88	Ford 7.5"	1	N/A	N/A
Mercury Grand Marquis	99-11	Ford 8.8"	1	N/A	N/A
Mercury Marauder	03-04	Ford 8.8"	1	N/A	N/A
Mercury Mountaineer	02-10	Ford 8.8"	1	Dana 35	1

DIRECTIONS: Pour entire contents (4 fl. oz.) into the differential. Applications with fluid capacities over 2 quarts will require using an additional 4 ounces. If necessary, remove enough gear oil to maintain proper level with supplement. Allow 20 miles of road operation for complete mixing.

IMPORTANT!

How many bottles of LUBEGARD® Limited Slip Supplement is required for your application?



APPLICATION	Year	Rear LS Differential	LG 4 oz. Treat	Front Differential	LG 4 oz. Treat
-------------	------	----------------------	----------------	--------------------	----------------

Mitsubishi

Montero Sport	97-04	7.5" or 8" LS Rear Differential	1	7.5" LS Front Differential	1
Montero Sport	93-06	7.5" or 8" LS Rear Differential	1	7.5" LS Front Differential	1
Pickup	93-96	7.5" or 8" LS Rear Differential	1	7.5" LS Front Differential	1
Raider	06-09	AA 8.25"	1	AA 9.25"	1

Nissan

300ZX	93-96	R230	1	N/A	N/A
Frontier 2 wd	98-04	H190A/C200/H233B	1	N/A	N/A
Frontier 2 wd	05-16	C200/M226	1	N/A	N/A
Frontier 4 wd	99-04	H190A/C200/H233B	1	R180A/R200A	1
Frontier 4 wd	05-16	C200/M226	1	M205	N/A
Pathfinder	96-04	H-190	1	R200	1
Pathfinder	93-95	H233B	1	R180	1
Pickup 2 wd	93-97	R180	N/A	N/A	N/A
Pickup 4 wd	93-97	H190/C200	1	R180	1
Xterra	00-10	H233B	1	R200A	1
Xterra	11-15	C200/M226	1	M205	1

Oldsmobile

Oldsmobile	73-79	GM 8.5" & 8.625"	1	N/A	N/A
Oldsmobile Bravada	01-09	GM 7.5", 7.625" & 8"	1	GM 7.25"	1
Oldsmobile Cutlas	73-77	GM 8.5" & 8.625"	1	N/A	N/A
Oldsmobile Ventura	73-79	GM 8.5" & 8.625"	1	N/A	N/A

Plymouth

Plymouth Baracuda	70-74	Chrysler 8.25" 10 bolt round cover	1	N/A	N/A
Plymouth Barecuda	64-69	Chrysler 7.5" 9 bolt	1	N/A	N/A
Plymouth Belvedere	62-70	Chrysler 8.25" 10 bolt round cover	1	N/A	N/A
Plymouth Belvedere	66-70	Chrysler 9.75" Dana 60 10 bolt cover	2	N/A	N/A
Plymouth Duster	70-76	Chrysler 7.5" 9 bolt	1	N/A	N/A
Plymouth Duster	73-76	Chrysler 8.25" 10 bolt round cover	1	N/A	N/A

DIRECTIONS: Pour entire contents (4 fl. oz.) into the differential. Applications with fluid capacities over 2 quarts will require using an additional 4 ounces. If necessary, remove enough gear oil to maintain proper level with supplement. Allow 20 miles of road operation for complete mixing.

IMPORTANT!

How many bottles of LUBEGARD® Limited Slip Supplement is required for your application?



APPLICATION	Year	Rear LS Differential	LG 4 oz. Treat	Front Differential	LG 4 oz. Treat
Plymouth Fury	73-76	Chrysler 8.25" 10 bolt round cover	1	N/A	N/A
Plymouth Fury	62-64	Chrysler 8.25" 10 bolt round cover	1	N/A	N/A
Plymouth Fury	75-83	Chrysler 9.25" 12 bolt round cover	1	N/A	N/A
Plymouth Grand Fury	82-89	Chrysler 7.5" 10 bolt	1	N/A	N/A
Plymouth GTX	67-74	Chrysler 9.75" Dana 60 10 bolt cover	2	N/A	N/A
Plymouth Road Runner	68-73	Chrysler 8.25" 10 bolt round cover	1	N/A	N/A
Plymouth Road Runner	68-72	Chrysler 9.75" Dana 60 10 bolt cover	2	N/A	N/A
Plymouth Savoy	62-64	Chrysler 8.25" 10 bolt round cover	1	N/A	N/A
Plymouth Satellite	73-74	Chrysler 8.25" 10 bolt round cover	1	N/A	N/A
Plymouth Satellite	65-74	Chrysler 8.25" 10 bolt round cover	1	N/A	N/A
Plymouth Satellite	65-72	Chrysler 9.75" Dana 60 10 bolt cover	2	N/A	N/A
Plymouth Scamp	72-76	Chrysler 7.5" 9 bolt	1	N/A	N/A
Plymouth Scamp	73-76	Chrysler 8.25" 10 bolt round cover	1	N/A	N/A
Plymouth Superbird	70	Chrysler 9.75" Dana 60 10 bolt cover	2	N/A	N/A
Plymouth Valient	60-76	Chrysler 7.5" 9 bolt	1	N/A	N/A
Plymouth Valient	73-76	Chrysler 8.25" 10 bolt round cover	1	N/A	N/A

Pontiac

Pontiac	64-69	GM 8.2/B.O.P. 8.2"	1	N/A	N/A
Pontiac Firebird	64-69	GM 8.2/B.O.P. 8.2"	1	N/A	N/A
Pontiac G8	08-09	GM 8.25 10" bolt	1	N/A	N/A
Pontiac GTO	04-06	GM 8" 10 bolt	1	N/A	N/A
Pontiac GTO	64-69	GM 8.2/B.O.P. 8.2"	1	N/A	N/A
Pontiac Trans AM	82-97	GM 7.5" & 7.62"	1	N/A	N/A
Pontiac Firebird	73-81	GM 8.5" & 8.625"	1	N/A	N/A

Scion

FRS	13-16	8.8" IRS Rear LS Differential	1	N/A	N/A
-----	-------	-------------------------------	---	-----	-----

Subaru

BRZ	13-16	8.8" IRS Rear LS Differential	1	N/A	N/A
-----	-------	-------------------------------	---	-----	-----

DIRECTIONS: Pour entire contents (4 fl. oz.) into the differential. Applications with fluid capacities over 2 quarts will require using an additional 4 ounces. If necessary, remove enough gear oil to maintain proper level with supplement. Allow 20 miles of road operation for complete mixing.

IMPORTANT!

How many bottles of LUBEGARD® Limited Slip Supplement is required for your application?



APPLICATION	Year	Rear LS Differential	LG 4 oz. Treat	Front Differential	LG 4 oz. Treat
Toyota					
FJ Cruiser	07-14	8" Rear LS Differential	1	7.5" IFS Front Differential	1
Land Cruiser	90-07	9.5" LS Differential	2	8" LS Front Differential	1
Pickup 2 wd	79-85	8" Rear LS Differential	1	N/A	N/A
Pickup 2 wd	86-95	7.5" Rear LS Differential	1	N/A	N/A
Pickup 4 wd	79-85	8" Rear LS Differential	1	8" Front LS Differential	1
Pickup 4 wd	86-95	8" Rear LS Differential	1	7.5" LS Front Differential	1
Sequoia 2 wd	01-07	8.75" LS Differential	1	N/A	N/A
Sequoia 2 wd	07-10	10.5" LS Differential	2	N/A	N/A
Sequoia 4 wd	01-07	8.75" LS Differential	1	8" Rev IFS	1
Sequoia 4 wd	07-10	10.5" LS Differential	2	8.75" IFS Front Differential	1
Supra	93-98	7.5" Rear LS Differential	1	N/A	N/A
T-100	93-98	8" Rear LS Differential	1	7.5" LS Front Differential	1
Tacoma 2 wd/4 wd	95-00	8" Rear LS Differential	1	7.5" LS Front Differential	1
Tacoma 2 wd/4 wd	01-03	8" Rear LS Differential	1	8" LS Front Differential	1
Tacoma 2 wd/4 wd	04-08	8" Rear LS Differential	1	8" LS Front Differential	1
Tundra 2 wd	00-07	8.75" LS Differential	1	N/A	N/A
Tundra 2 wd	07-10	10.5" LS Differential	2	N/A	N/A
Tundra 4 wd	00-07	8.75" LS Differential	1	8" Rev IFS	1
Tundra 4 wd	07-10	10.5" LS Differential	2	8.75" IFS Front Differential	1

Volvo

240 Series	93	Dana LS/Eaton Automatic Lock	1	N/A	N/A
940/960	93-97	Dana LS/Eaton Automatic Lock	1	N/A	N/A
S70/V70	98-04	Rear LS Differential	1	N/A	N/A
S80	99-04	Rear LS Differential	1	N/A	N/A
S90/V90	98	Dana LS/Eaton Automatic Lock	1	N/A	N/A
XC 90	03-04	Rear LS Differential	1	N/A	N/A

DIRECTIONS: Pour entire contents (4 fl. oz.) into the differential. Applications with fluid capacities over 2 quarts will require using an additional 4 ounces. If necessary, remove enough gear oil to maintain proper level with supplement. Allow 20 miles of road operation for complete mixing.

Shop for other oils, fluids, lubricants on our website.