



QUALITY... PLAIN & SIMPLE®

FiTech Go EFI Throttle Cable Bracket Installation Instructions

FiTech Go EFI Throttle Cable Bracket Installation Instructions

General Installation Notes:

Please read these instructions completely before beginning the installation. If you have any questions, please call.

Before beginning the installation, disconnect the negative battery cable and use wheel chocks to block the vehicle's wheels.

Make sure the engine, transmission, body and frame are properly grounded. We recommend using anti-seize lubricant on all aluminum threads.

The Lokar Throttle Cable Bracket kit is designed to be used with a Lokar Throttle Cable.

Step 1: Remove the throttle body mounting bolt from the left rear corner of the throttle body, and position the Lokar Throttle Cable Bracket as shown in **Fig. 2**. Loosely re-install the original throttle body mounting bolt.

Step 2: Install the provided 5/16"-24 x 1/2" button head bolt with the lock washer through the Throttle Cable Bracket and into the left side of the throttle body, and tighten the button head bolt. **Fig. 2** and **Fig. 3**

Step 3: Tighten the left rear throttle body mounting bolt.

Step 4: Connect the inner and outer springs to the small hole in the throttle lever, and to the bottom hole in the Throttle Cable Bracket. **Fig. 3**

Step 5: When the Throttle Cable (not included) is installed, place the aluminum bushing from this kit onto the stud on the carb end assembly (not included, comes with the Throttle Cable) before connecting the carb end assembly to the throttle lever. The aluminum bushing acts as a spacer, and is required for proper Throttle Cable alignment. **Fig. 4**

NOTE: The aluminum bushing **MUST** be installed in order to get the proper Throttle Cable alignment!

Proceed with the Throttle Cable installation.

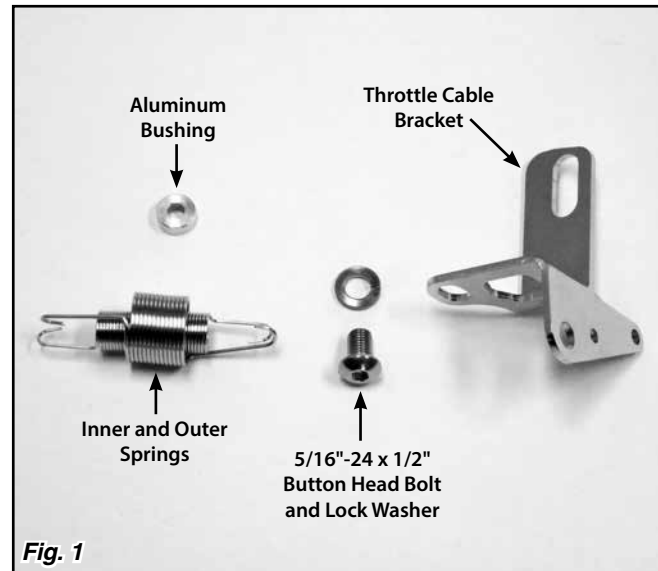

Fig. 1

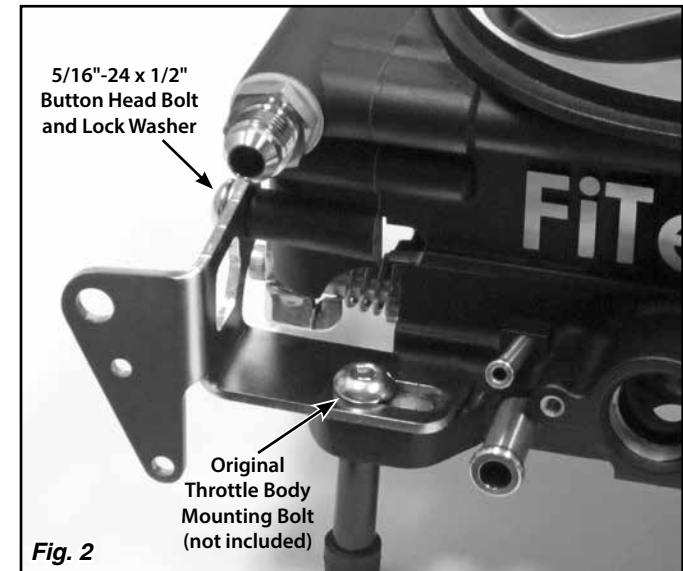

Fig. 2

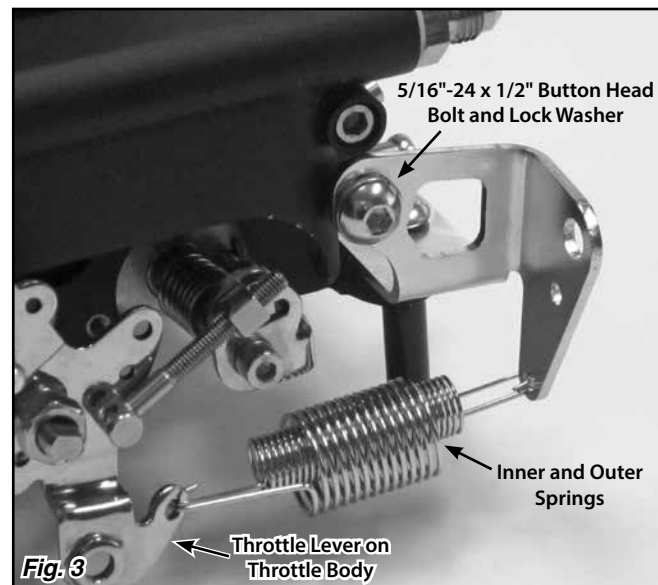

Fig. 3

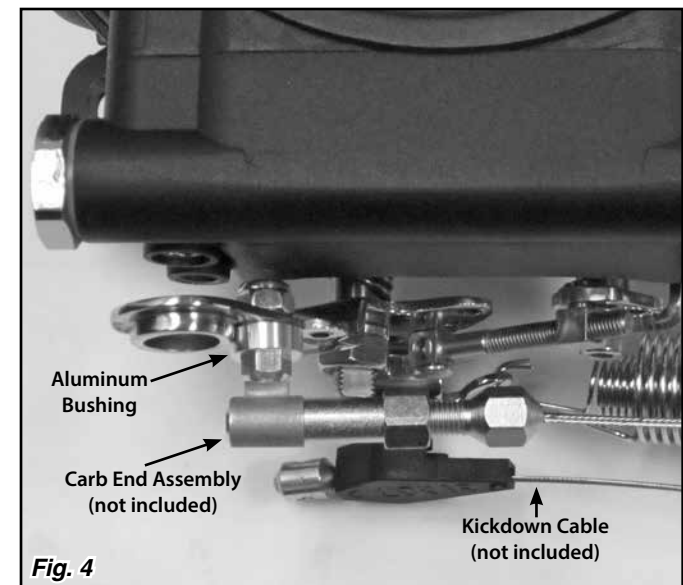

Fig. 4