



QUALITY... PLAIN & SIMPLE®

## Transmount Emergency Hand Brake Installation Instructions

### General Installation Notes:

Please read these instructions completely before beginning the installation.

Before beginning the installation, disconnect the negative battery cable and use wheel chocks to block the vehicle's wheels.

**NOTE:** This hand brake is designed for use with a Lokar Transmount Shifter and Lokar Transmount Emergency Brake Cable Kit.

Refer to Fig. 1 for the component names.

**Step 1:** Install the Lokar Transmount Shifter before beginning installation of the Emergency Hand Brake.

**Step 2:** If you are using the Lokar Transmount Emergency Brake Cable Kit, remove the clevis pin and clevis from the Hand Brake and discard. Make sure to keep the 5/16" flat washer and 1/8" x 1/2" cotter pin for use during reassembly. Install the clevis and clevis pin that came with the Lokar Transmount Emergency Brake Cable Kit into the Hand Brake. Discard ONE of the supplied 3/4" spacers (you will only need one 3/4" spacer with the Lokar Transmount Emergency Brake Cable Kit).

If you are **NOT** using the Lokar Transmount Emergency Brake Cable Kit, the supplied clevis may be modified or replaced as required in order to connect to your existing cables. Make sure to keep the 5/16" flat washer and 1/8" x 1/2" cotter pin for use during reassembly. You will use both of the supplied 3/4" spacers to go between the Hand Brake and the Lokar shifter mount bracket or your custom bracket.

**Step 3:** The brake cable bracket from the Transmount Emergency Brake Cable Kit will be installed at the same time as the Hand Brake. The Transmount Emergency Brake Cable Kit contains three 3/8" spacers and one 1/4" spacer to center the Hand Brake in the brake cable bracket. On the front mounting bolt, install one 3/8" spacer on the right side between the brake cable bracket and the hand brake, and one 3/4" spacer on the left between the Hand Brake and the shifter mount bracket.

On the rear mounting bolt, install one 3/8" spacer on the right between the brake cable bracket and the Hand Brake, one 3/8" spacer on the left between the Hand Brake and the brake cable bracket, and one 1/4" spacer between the brake cable bracket and the shifter mount bracket. **Fig. 2**

# Transmount Emergency Hand Brake Installation Instructions

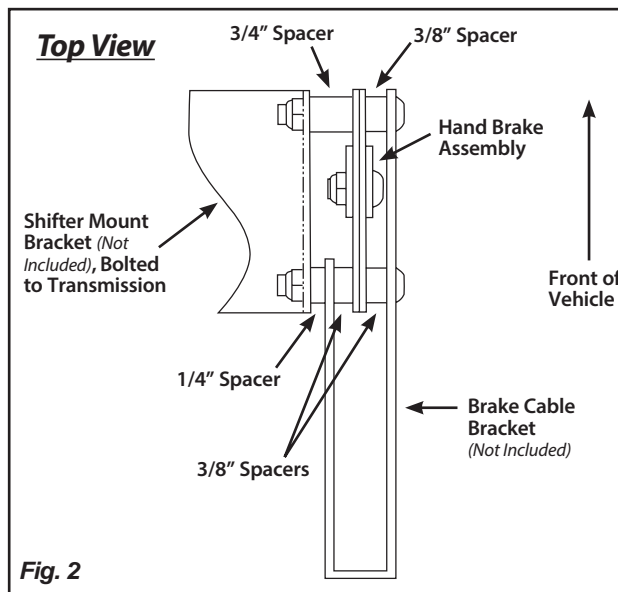
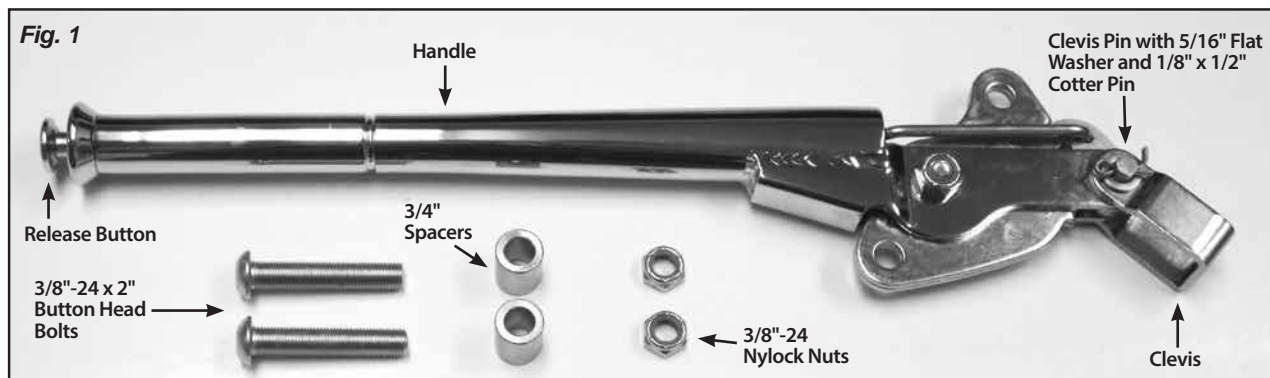

**Step 4:** Follow the instructions for the Transmount Emergency Brake Cable Kit to connect the emergency brake cables. Adjust the Hand Brake so that there is no slack, but make sure that the brakes are not applied when the Hand Brake is released. Generally, you will want the cables adjusted so that three clicks of the Hand Brake will prevent the vehicle from moving (although your braking system may be different). Your completed installation should look like **Fig. 3**.

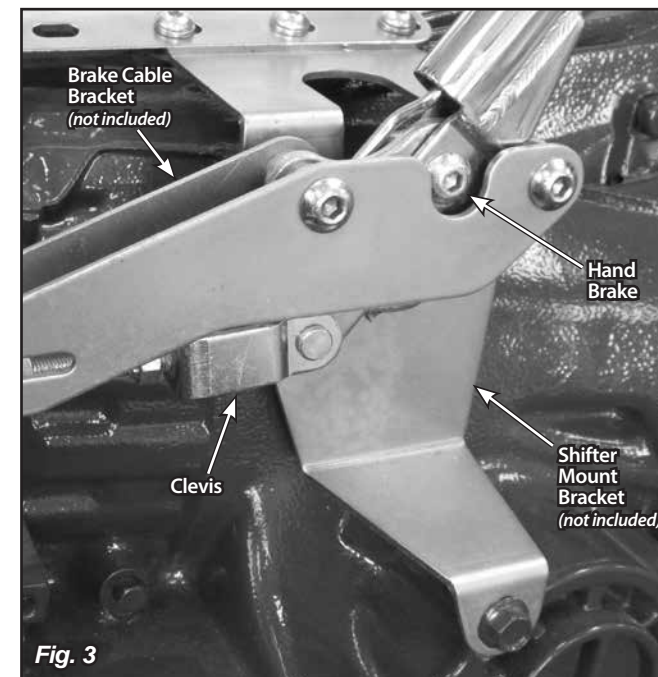

**NOTE:** To release the Hand Brake, you must pull up slightly on the handle while depressing the release button. Keep the release button depressed while you lower the handle to its at-rest position.