



QUALITY... PLAIN & SIMPLE®

Ford Explorer/Internal Wilwood Emergency Brake Cable Installation Instructions

General Installation Notes:

Please read these instructions completely before beginning the installation.

Before beginning the installation, disconnect the negative battery cable and use wheel chocks to block the vehicle's wheels.

Make sure the engine, transmission, body and frame are properly grounded. We recommend applying anti-seize lubricant to all aluminum threads before final assembly.

These Emergency Brake Cables are designed to be used with either Lokar's Connector Cables or Lokar's Floor Mount Emergency Hand Brake.

Refer to Figs. 1, 2 and 3 for the component names.

Step 1: Remove the inner wires, brake cable springs, and the 7/16"-20 thin nylock nuts from the backing plate fittings on the new Lokar cable housings.

Step 2: Insert the backing plate fittings into the backing plate brackets, and secure each one with a 7/16"-20 thin nylock nut. The backing plate brackets are part of the braking system and are not supplied by Lokar. **Fig. 4**

Step 3, All Except Trans Mount Hand Brake: Determine where the cable adjuster bracket is going to be mounted. The cable adjuster bracket must be positioned so that the Cables are being pulled in a straight line between the cable adjuster bracket and the brake cable clevis.

Mount the cable adjuster bracket securely to the vehicle floor or frame. Adjust the position of the cable adjusters so that they are threaded about three-quarters of the way into the cable adjuster bracket.

Step 3, Trans Mount Hand Brake Only: The cable adjuster bracket will be installed at the same time as the Lokar Hand Brake assembly. Included in the Emergency Brake Cable Kit there are three 3/8" spacers and one 1/4" spacer to center the Hand Brake in the cable adjuster bracket. On the front mounting bolt, install one 3/8" spacer on the right side between the cable adjuster bracket and the Hand Brake, and one 3/4" spacer (not included, part of the Trans Mount Hand Brake kit) on the left between the Hand Brake and the shifter mount bracket. On the rear mounting bolt, install one 3/8" spacer on the right between the cable adjuster bracket and the Hand Brake; one 3/8" spacer on the left between the Hand Brake and the brake cable bracket; and one 1/4" spacer between the brake cable bracket and the shifter mount bracket. **Fig. 5**

Install the cable adjusters into the cable adjuster bracket, and position them so that they are threaded about three-quarters of the way into the cable adjuster bracket.

Ford Explorer/Internal Wilwood Emergency Brake Cable Installation Instructions

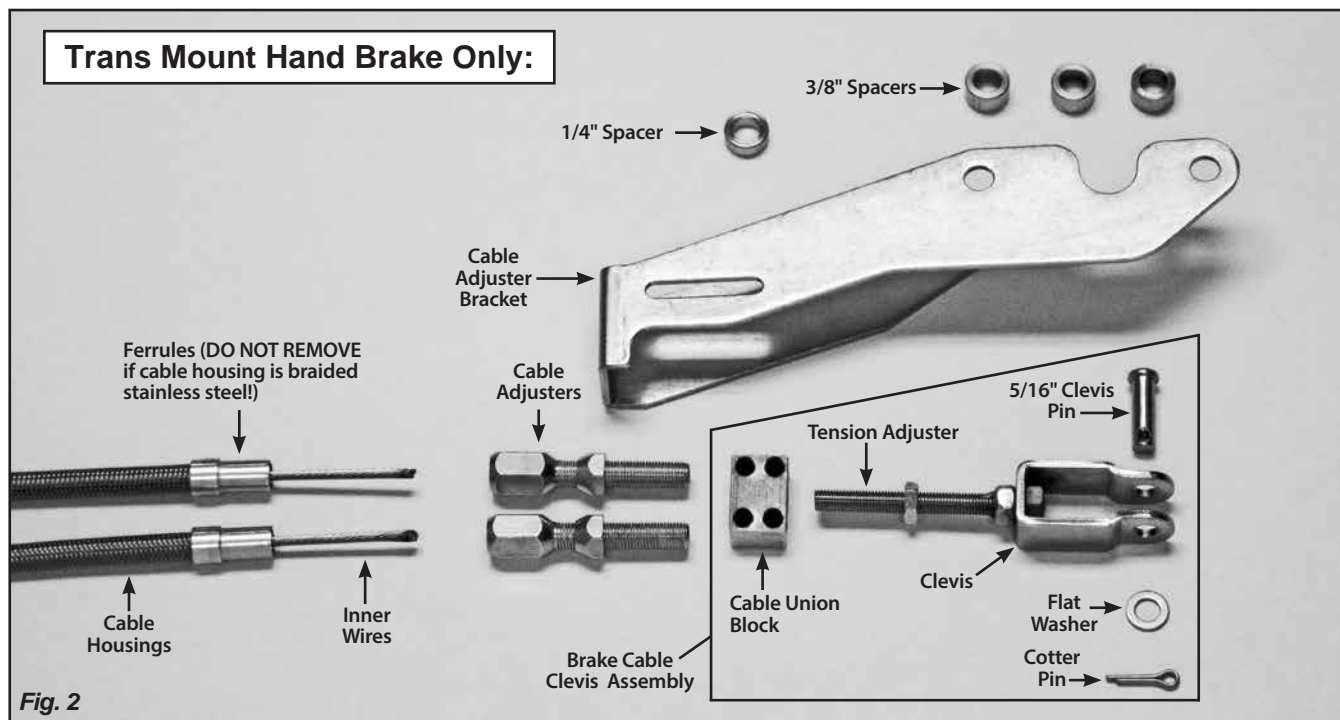
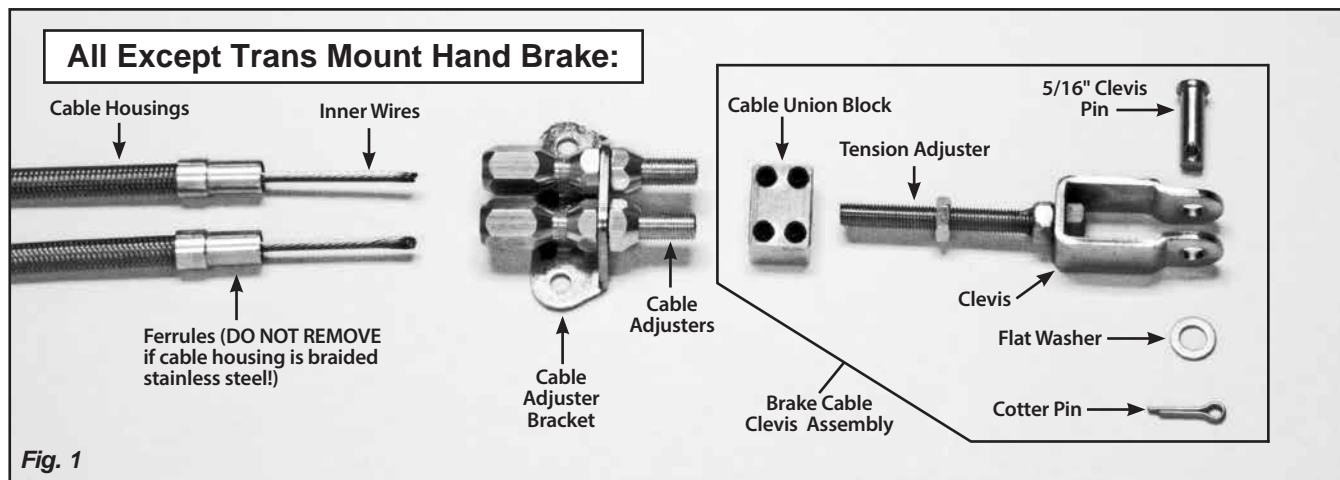

Ford Explorer/Internal Wilwood Emergency Brake Cable Installation Instructions

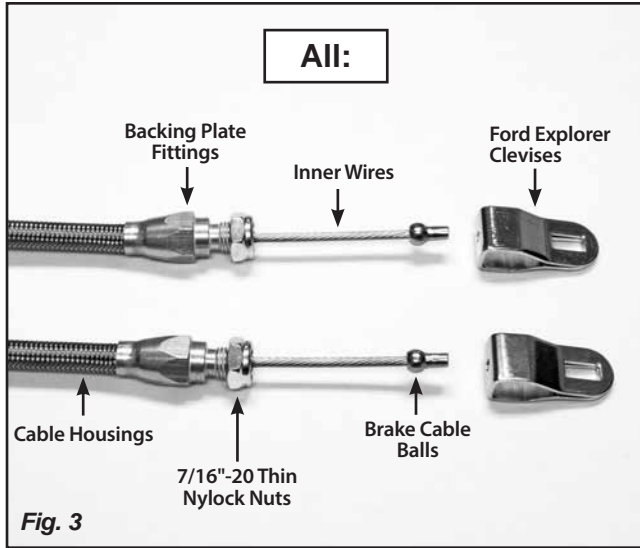

Step 4: Route the cable housings up to the cable adjuster bracket. Be sure to keep the cable housings a safe distance away from the exhaust and from any moving parts. Cable housings that are damaged or melted will not be covered under warranty.

Support the cable housings securely.

Step 5: It will be necessary to shorten the cable housings. **Make sure that the inner wires are removed from the cable housings!** Mark the cable housings where they line up with the cable adjuster bracket.

If the cable housings are braided stainless steel, slide the ferrules back towards the rear end, away from the ends that are being cut. **DO NOT remove the ferrules from the braided stainless steel housings!** Wrap tape around the area to be cut and use an abrasive cutoff wheel or fine-toothed hacksaw to cut the cable housings at your mark.

Step 5: (continued) If the cable housings are black universal, remove the ferrules. Cut the cable housings at your mark using heavy duty 8" diagonal cutting pliers or a hacksaw. Lokar recommends Klein brand Diagonal Cutting Pliers # D2000-28, available at The Home Depot or through Grainger Industrial Supply, part # 4A838.

After cutting the cable housings, put the ferrules back in place at the end of the cable housings. The ferrules do not need to be crimped or otherwise attached in place.

Step 6: Insert the cable housings and ferrules into the cable adjusters on the cable adjuster bracket.

Step 7: Install the Ford Explorer clevises onto the inner wires by sliding the end of the inner wire without the ball end on it through the 1/8" hole from inside the U-shaped part of the clevis. Pull the inner wire through the clevis until the brake cable ball on the end of the inner wire stops inside the clevis. **Fig. 6**

Install the inner wires into the cable housings starting from the backing plate fittings.

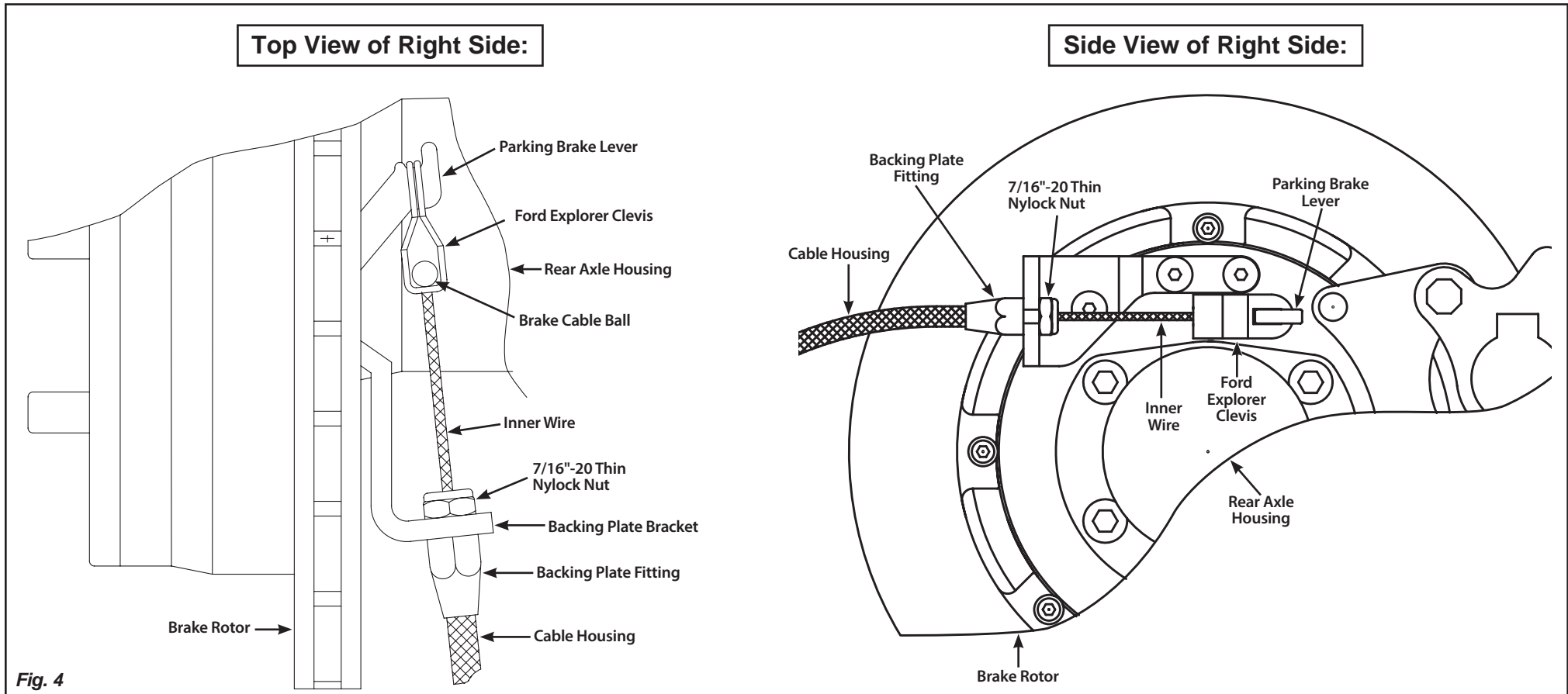

**Trans Mount
Hand Brake Only,
Top View:**

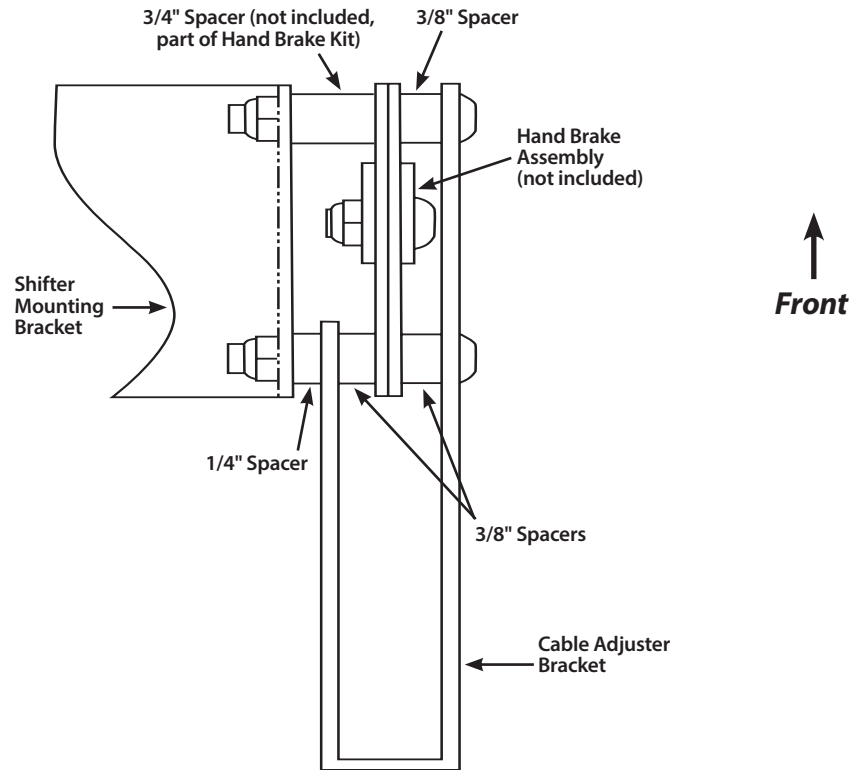

Fig. 5

- Step 8:** Hook the Ford Explorer clevis onto the parking brake lever that was supplied with your rear brake kit.
- Step 9:** Make sure the emergency brake is in the fully off position. If you are using either a Lokar Floor Mount Emergency Hand Brake or a Lokar Trans Mount Emergency Hand Brake, discard the clevis that came with the Hand Brake. Connect the brake cable clevis assembly to the Hand Brake using the 5/16" clevis pin, flat washer, and cotter pin. If you are using a Lokar Connector Cable, remove the tension adjuster and clevis from the cable union block, and install the 5/16"-28 threaded rod with jam nuts (not included) from the Connector Cable Kit into the cable union block.
- Step 10:** Loosen the set screws in the cable union block, and insert the inner wires into the cable union block. Using a pair of pliers, pull on each of the inner wires until there is no slack left in the inner wire. Tighten the set screws in the cable union block while each inner wire is being held with no slack.
- Step 11:** The Cables should be adjusted evenly. Adjust the cable tension at the tension adjuster so that there is no slack, but making sure that the brakes are not applied when the emergency brake is released. Use the cable adjusters to fine tune the individual Cable adjustment. Generally, you will want the Cables adjusted so that three clicks of the emergency brake will prevent the vehicle from moving (although your braking system may be different).
- Step 12:** Once the Cables are properly adjusted, cut off the excess inner wires. It is recommended that you leave approximately one inch of extra inner wire extending beyond the cable union block to allow for future adjustments.
- See **Figs. 7, 8, 9, and 10** for completed installations.

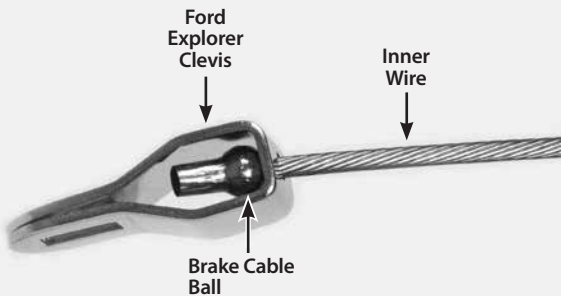

Fig. 6

Side View of Left Side:



Fig. 7

All Except Trans Mount, Without Connector Cable:

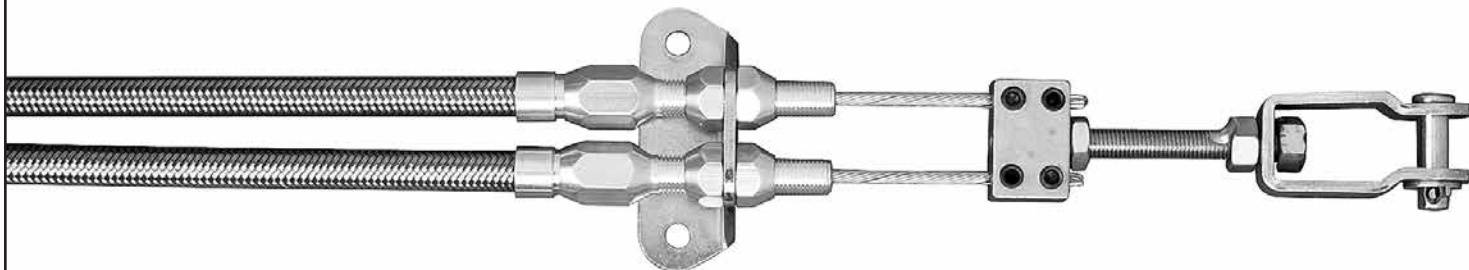

Fig. 8

Front →

Trans Mount Only:

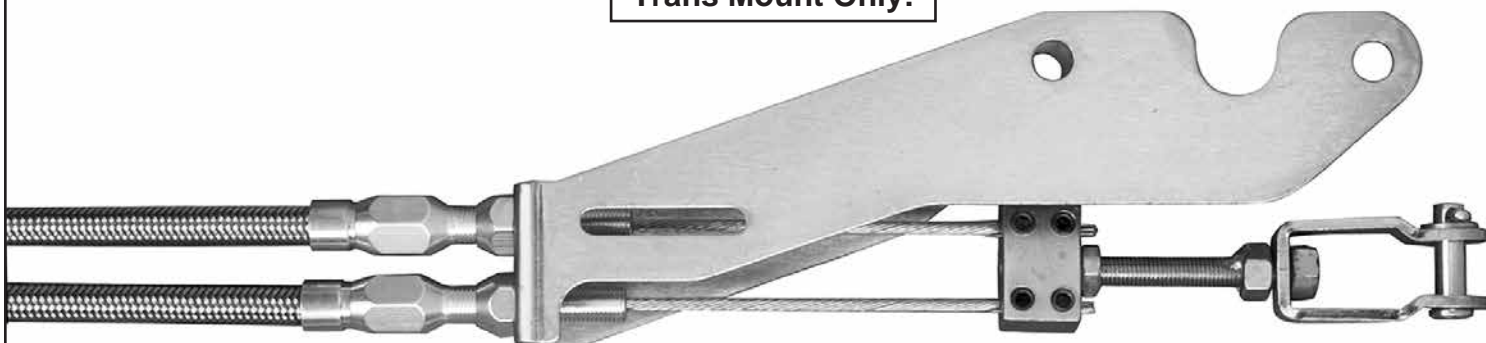

Fig. 9

Front →

All Except Trans Mount, With Connector Cable:

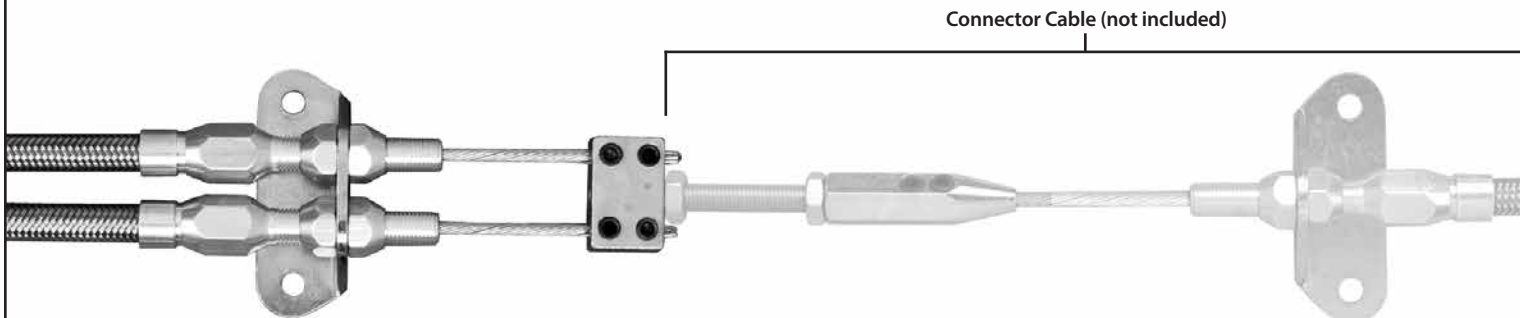

Fig. 10

Front →