



Transmount Emergency Brake Cables

Part# EC-80TU and EC-80THT

Step 3: Route outer housing to brake cable bracket; make sure to route housing away from the tail pipes and drive shaft. **Do not cut housing too short.**

Step 4: Cut black outer housing with heavy brand 8" diagonal-cutting pliers or hacksaw. If outer housing is braided stainless steel style, tape and cut with abrasive cut-off saw or fine toothed hacksaw. **Lokar recommends Klein brand Diagonal-Cutting Pliers # D-2000-28 available at Home Depot or through W.W. Graingers, Part # 4A838.**

Step 5: Feed springs onto inner wire and install from backing plates. Set adjuster about three-quarters of the way in and feed inner cable to cable junction block and set setscrews. **See Diagrams.**

Step 6: Adjust cable evenly; make sure that the hand brake lever goes all the way forward on the first adjustment.

Top View

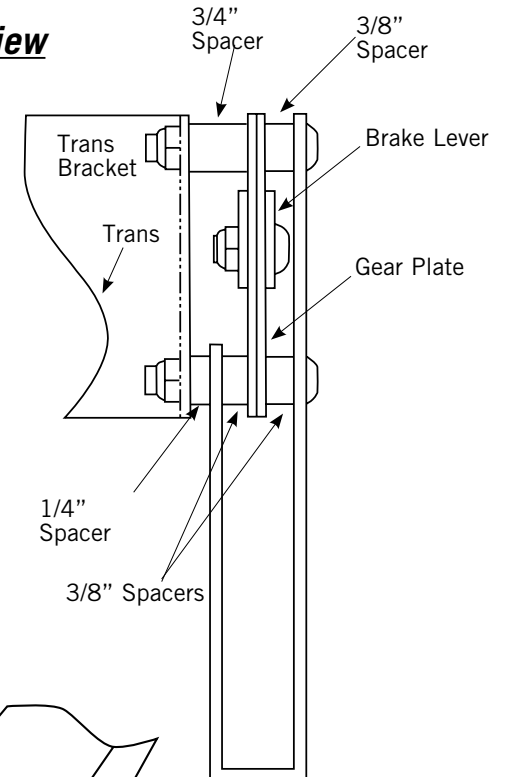

General Installation Notes:

Please read instructions completely before beginning installation.

NOTE: These cables are for use with Lokar's Transmount Emergency Hand Brake, Part # EHB-7011 or EHB-7016.

Recommendation for Aluminum Fittings: We recommend that you use an anti-seize lubricant on all aluminum nuts before tightening.

Transmount Emergency Brake Cable Installation

Step 1: Remove the rear brake drums and install the backing plate fittings and cables in the original cable holes. **If using late Corvette or Wilwood external parking calipers, you need Lokar's Part # EC-80WC Wilwood Clevis Kit.**

Step 2: The single 3/4" spacer that came with bolts and hand brake is to be placed in left side of hand brake, gear plate to the front. Included in the brake cable kit and bracket there are three (3) 3/8" wide and one (1) 1/4" spacers to center the brake cable bracket. Place two (2) 3/8" spacers to the outside of the gear plate, one (1) 3/8" spacer to the inside of gear plate and place one (1) 1/4" spacer to the inside of the gear plate between the cable bracket and trans bracket. **See Diagrams.**

Side View

