

LOWE
DESTROYER SERIES
TRUCK
BULL BAR

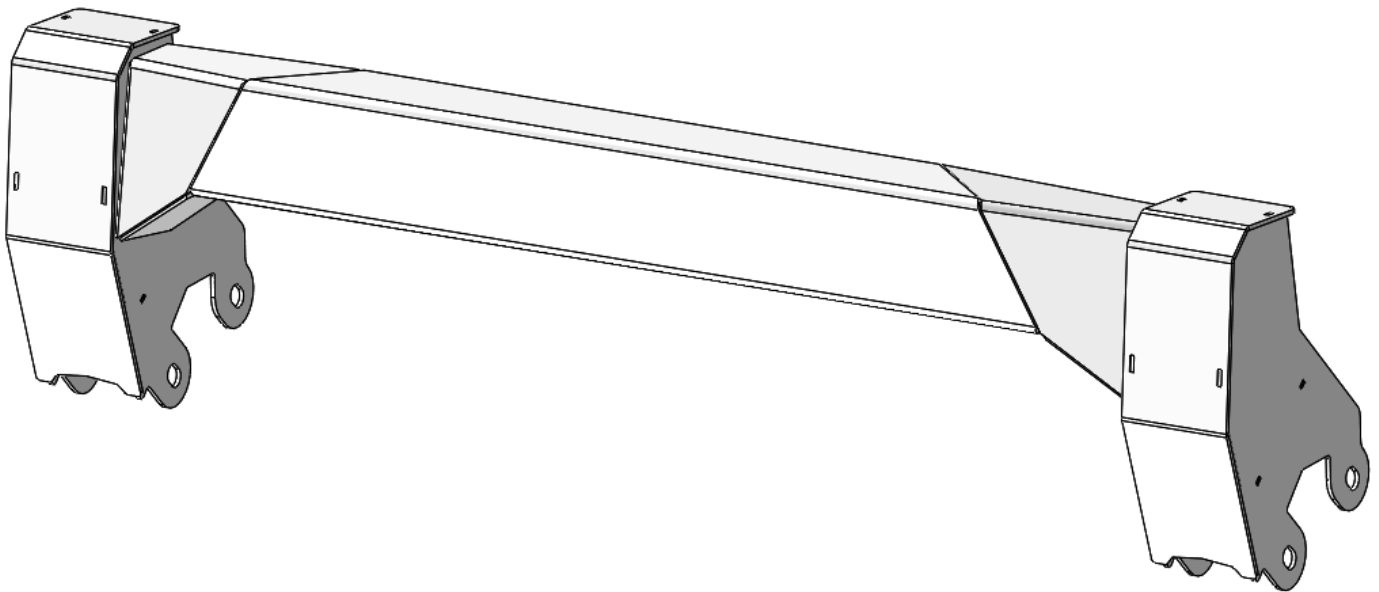

VERIFY YOU HAVE ALL THE COMPONENTS BEFORE STARTING THE INSTALLATION. REFER TO THE ENGINEERING DRAWINGS AT THE END OF THIS DOCUMENT FOR A COMPLETE PARTS LIST



Remove the two upper $\text{\O}1/2$ " Bolts that connect your Bumper Center thru the Tow Point and Wing.

This picture shows the Wing removed for clarity. ****Do not remove the Wing.****

Leave the lower two Bolts in place and tight during the Bull Bar installation. This will keep your Wing from changing positions during installation.

Remove these two bolts

Leave these in place and tight

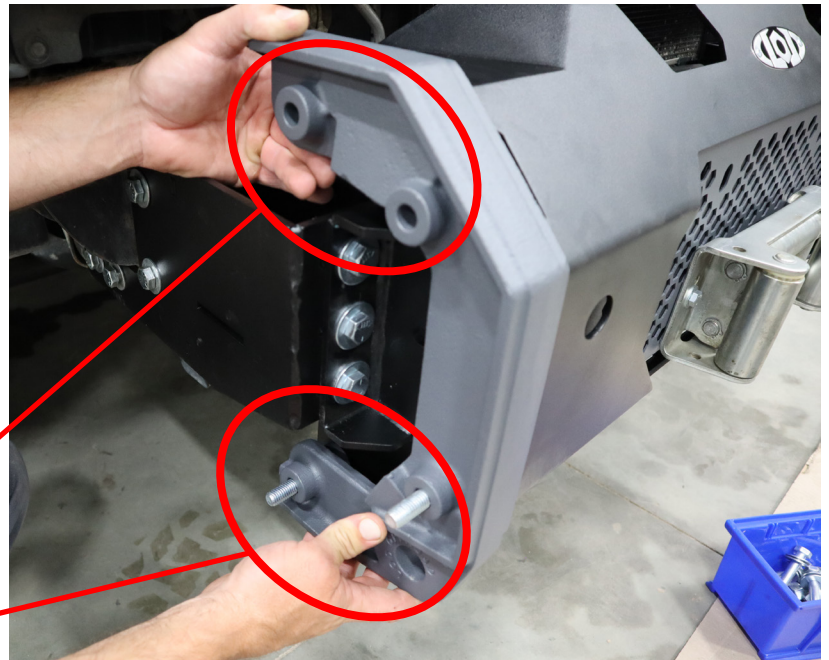

Next install the Bull Bar Towers as shown into the slots at the top of the bumper and wing. Reinstall the $\text{\O}1/2$ " Hex Bolts thru the bumper, wing, tow points and Bull Bar Tower. Leave these bolts loose while your finish the installation.

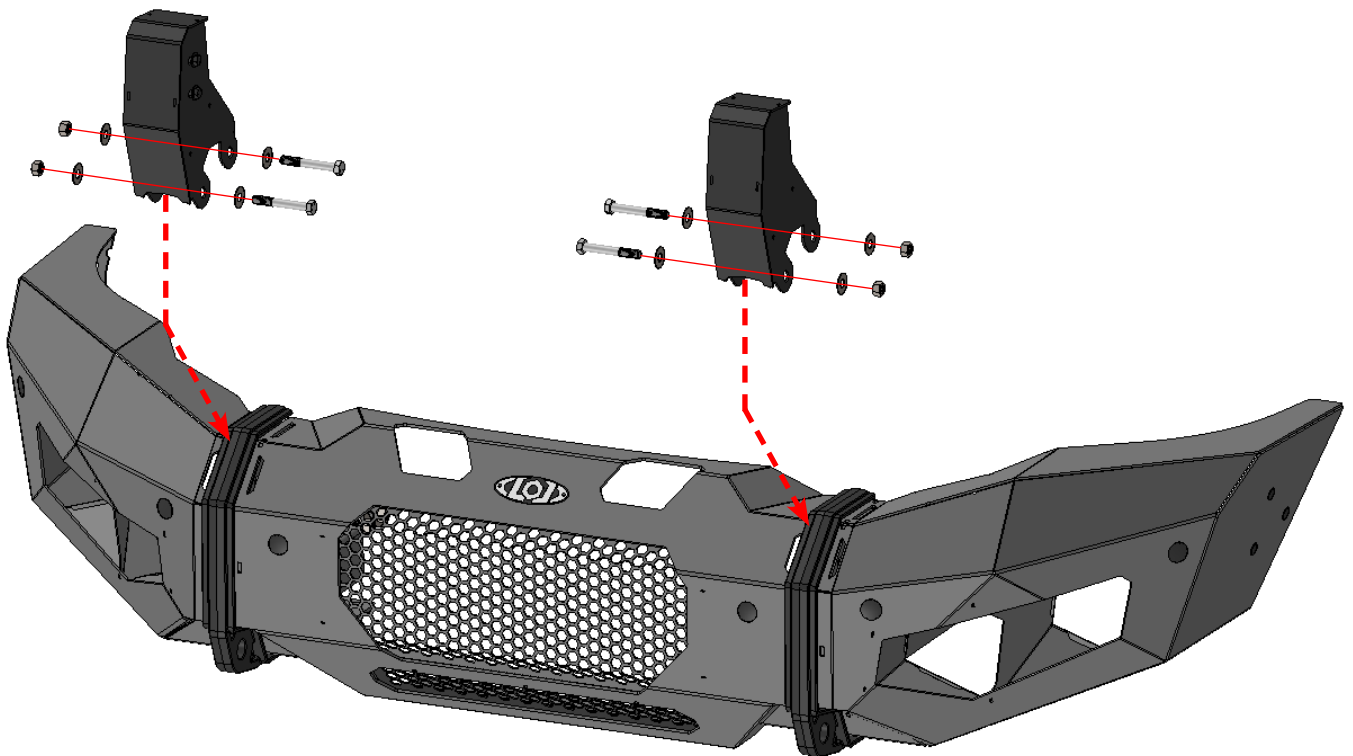

Next loosely assembly the Bull Bar Center Bar as shown between the towers using the Ø3/8" Hex Bolts.

Position the Bull Bar and Towers as needed and tighten the Ø3/8" Hex Bolts securely.

With the Bull Bar in its final position, tighten the remaining four Ø1/2" Hex Bolts that connect the Bull Bar to your bumper.

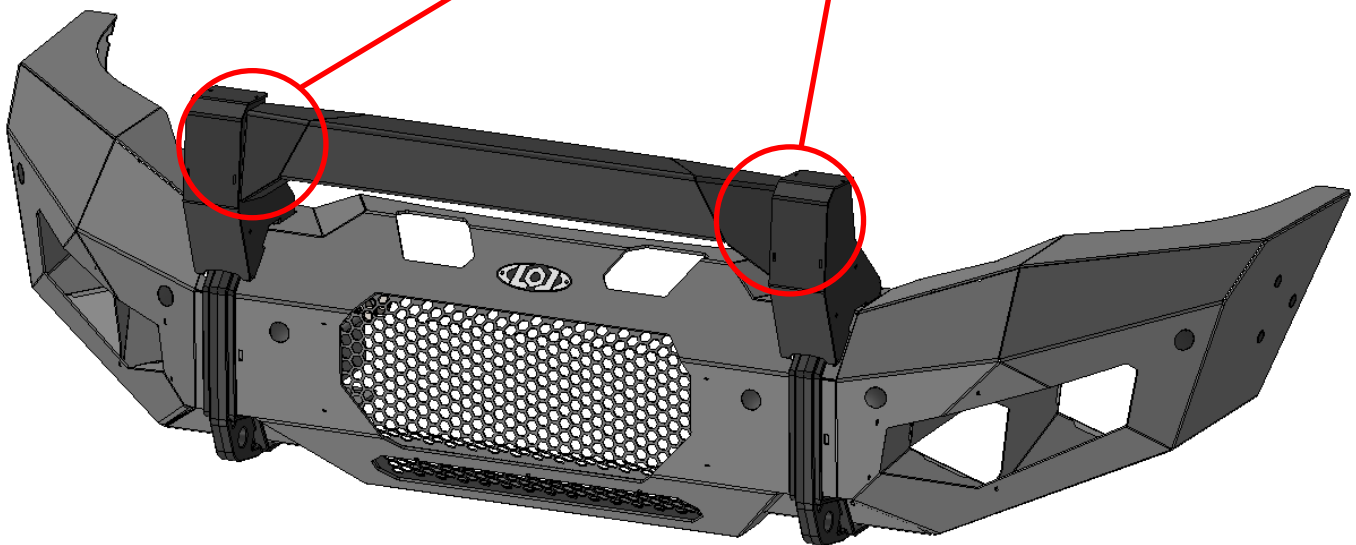
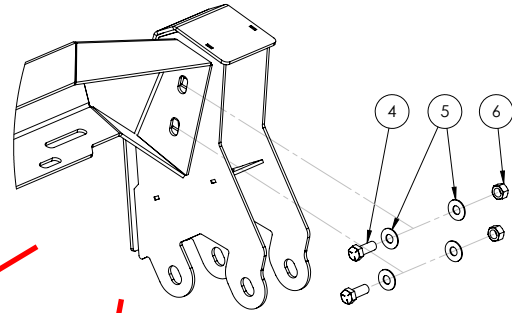

****Maintenance****

- Periodically check and re-tighten all fasteners.
-
- Periodically check your product for scratches, dings, or rust spots which can happen over time or after heavy use. It is important to address these areas as soon as possible to prevent rust and corrosion from spreading. We recommend using Rustoleum® brand Black Semi-Gloss Protective Enamel (oil based). Apply using a foam brush by dabbing to match the powder coat texture.



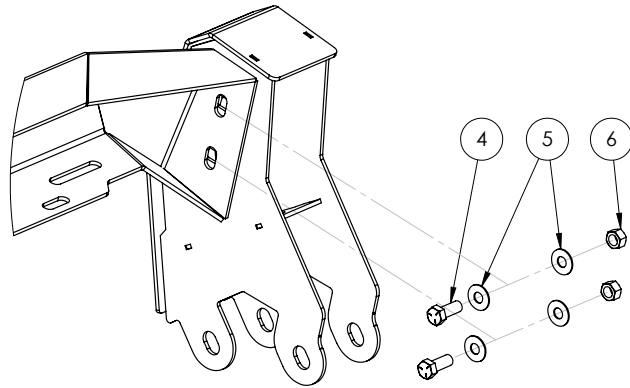

ITEM NO.	PART NUMBER	DESCRIPTION	QTY.
1	4MFG2020-02	CENTER BAR	1
2	4MFG2020-04	BULL BAR TOWER - PS	1
3	4MFG2020-05	BULL BAR TOWER - DS	1

BOLT KIT

ITEM NO.	PART NUMBER	DESCRIPTION	QTY.
4	HB381616ZPGR5	HEX BOLT 3/8-16 X 1.00 ZINC PLATE GR5	4
5	FW3114ZP	FLAT WASHER Ø5/16" X .875" ZINC PLATE	8
6	HN3816ZPGR5	HEX NUT 3/8-16 ZINC PLATE GR5	4

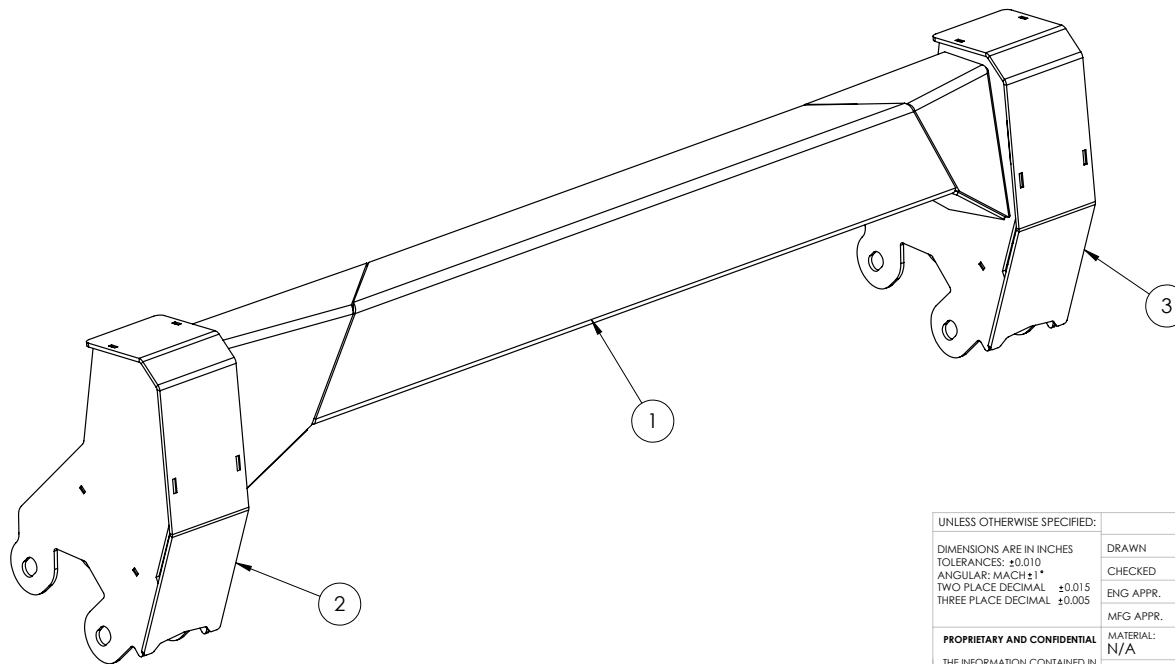

NOTES:

1. MFG2020 = BARE STEEL OPTION
2. MFG2021 = BLACK POWDER COAT

UNLESS OTHERWISE SPECIFIED:		NAME	DATE	LOD LLC. DESCRIPTION: DESTROYER MOD BULL BAR		
DIMENSIONS ARE IN INCHES TOLERANCES: ±0.010 ANGULAR: MACH ±1° TWO PLACE DECIMAL ±0.015 THREE PLACE DECIMAL ±0.005		DRAWN	MCH 6/15/2021			
PROPRIETARY AND CONFIDENTIAL THE INFORMATION CONTAINED IN THIS DRAWING IS THE SOLE PROPERTY OF LOD LLC. ANY REPRODUCTION IN PART OR AS A WHOLE WITHOUT THE WRITTEN PERMISSION OF LOD LLC IS PROHIBITED.		CHECKED		DWG. NO. MFG2020 MFG2021	REV A	
		ENG APPR.				
		MFG APPR.		SCALE: 1:4	SHEET SIZE: B	SHEET 1 OF 1
		MATERIAL: N/A				
		FINISH: SEE NOTES				
		ECCO: -				



**TRUCK
DESTROYER SERIES
BULL BAR
SHIPPING SHEET**

Packaged by:

On:



INSTRUCTION
SHEET

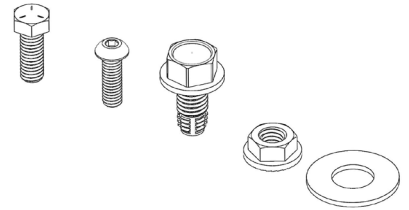

BOLT KIT
(may vary)

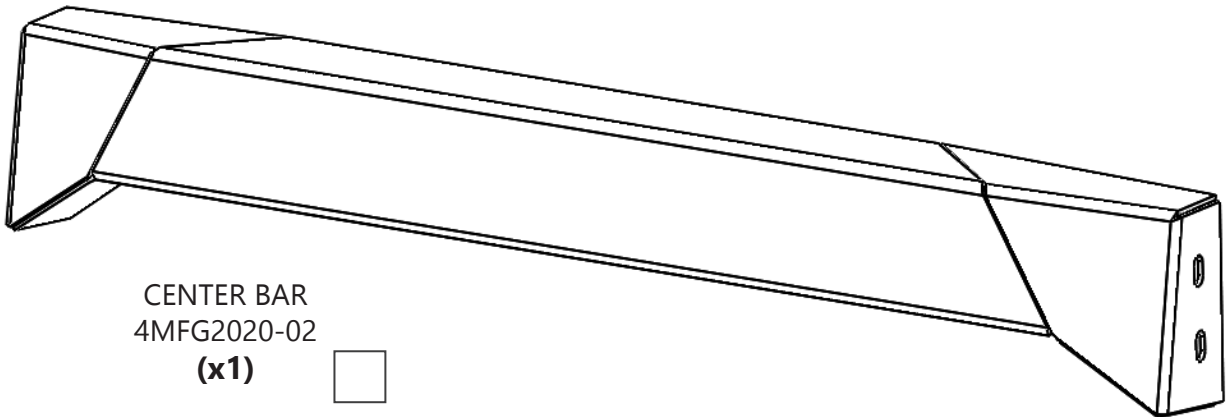

CENTER BAR
4MFG2020-02
(x1)

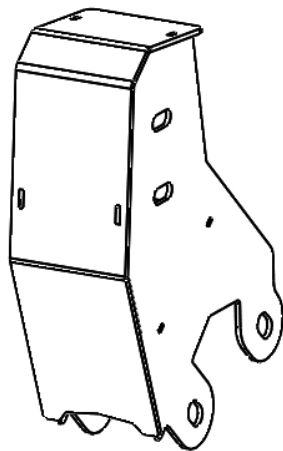

BULL BAR TOWER - PS
4MFG2020-04
(x1)

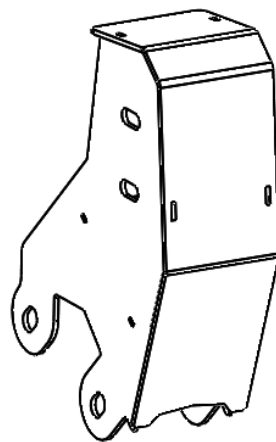

BULL BAR TOWER - DS
4MFG2020-05
(x1)





TRUCK
DESTROYER SERIES
BULL BAR
Bolt Kit
Packaged by:

On:

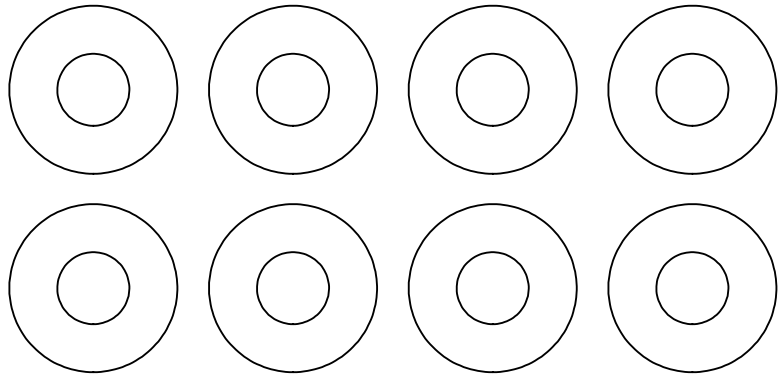

FLAT WASHER
Ø5/16" X .875"
(0159722)
(x8)

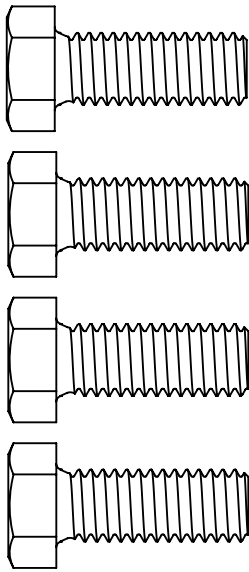

HEX BOLT 3/8-16 X 1.00"
(0137514)
(x4)

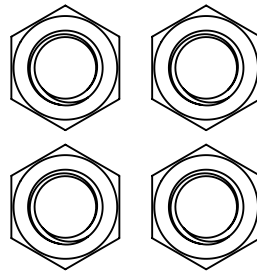

HEX NUT 3/8-16
(0147966)
(x4)

