



# DESTROYER SERIES TIRE RISER

AFTERMARKET OR STOCK BUMPERS



Open the tailgate.



Remove the liner.



Close the tailgate and use a 13mm or 1/2" to remove the eight (8) bolts securing the tire carrier.





Next, attach the riser plates using the bolts from the previous step. **HAND-TIGHTEN** these! The driver in the picture was simply used to speed up the process, and we hand-tightened the bolts at the end.



Attach the second riser plate. Try to keep the top surfaces parallel as shown with the dotted line. **REMEMBER TO HAND TIGHTEN** them thoroughly.



Now re-attach the carrier to the tailgate using the provided 5/16" bolts and washers.

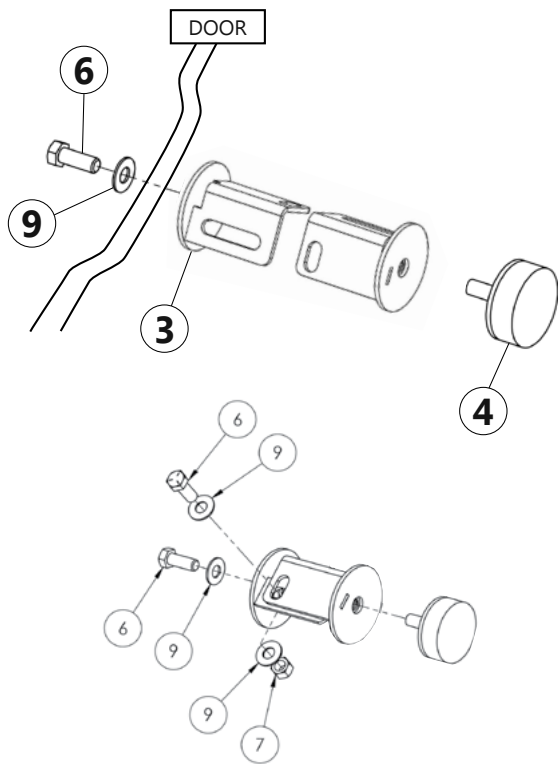

Attach the risers with the 3/8" bolts (6) and washers (8) as shown.

Thread on the tire risers. If you're worried about them unthreading, you can add some Loctite to the threads.





Do not over-tighten, as you can strip out the threads in the internal weld nuts.



You are now done with the install! You should be able to run up to a 37" tire.

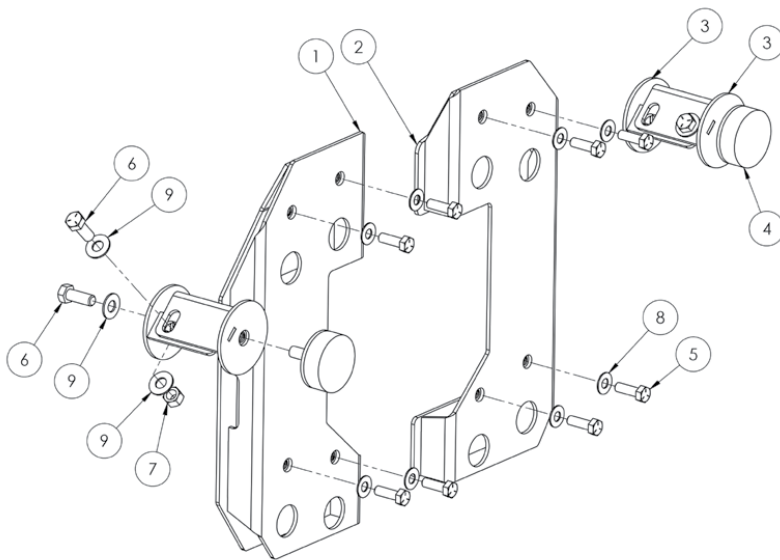

ITEM NO.	PART NUMBER	DESCRIPTION	QTY.
1	4JTC1800-01	Tire Riser Weldment Driver Side	1
2	4JTC1800-02	Tire Riser Weldment Pass Side	1
3	4JTC1800-03	ADJUSTABLE TIRE ISOLATOR	4

**HARDWARE KIT**

ITEM NO.	PART NUMBER	DESCRIPTION	QTY.
4	2JTC1800-07	Threaded Rubber Isolator Pad	2
5	HB311816ZPGR5	HEX BOLT 5/16-18 X 1.00 ZINC PLATE GR5	8
6	HB381616ZPGR5	HEX BOLT 3/8-16 X 1.00 ZINC PLATE GR5	6
7	HN3816ZPGR5	HEX NUT 3/8-16 ZINC PLATE GR5	4
8	FW3112ZP	FLAT WASHER Ø5/16" X .75" ZINC PLATE	8
9	FW3814ZP	FLAT WASHER Ø3/8" X .875" ZINC PLATE	10

DESTROYER 2" TIRE RISER  
JTC1801



**JL Jeep  
DESTROYER SERIES**

Tire Riser  
Shipping Sheet  
Packaged by:

\_\_\_\_\_

On:

\_\_\_\_\_

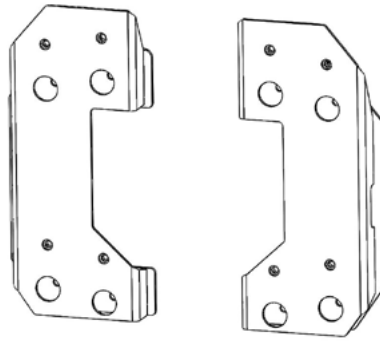

Destroyer Series  
Tire Riser



Install Instruction Booklet

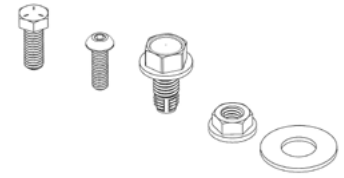

Bolt Kit (contents  
may vary)

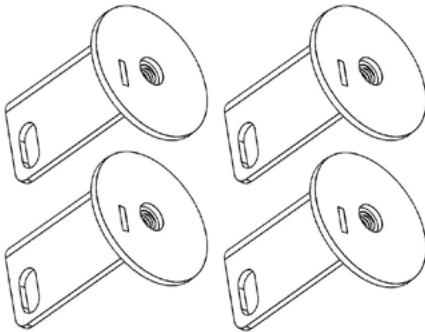

Isolator  
Extensions  
(x4)



**JL Jeep  
DESTROYER SERIES**

Tire Riser

Bolt Kit

Packaged by:

\_\_\_\_\_

On:

\_\_\_\_\_

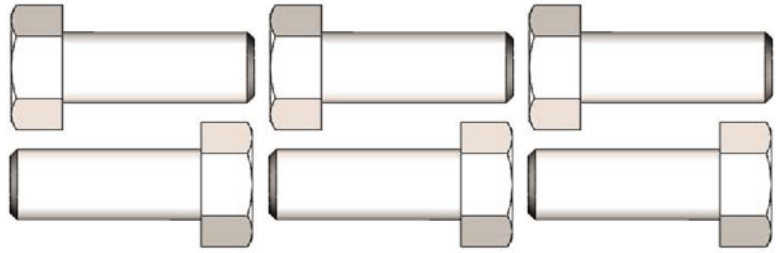

3/8"x1 Bolts

**(x6)**

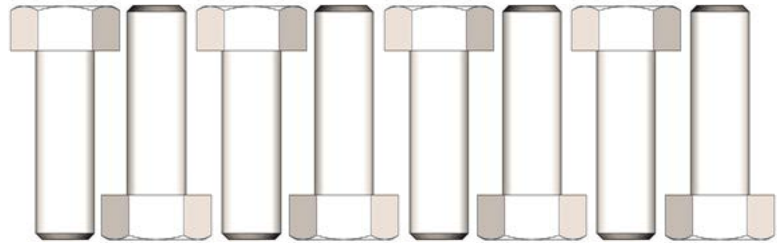

5/16" x 1"  
HexBolts

**(x8)**

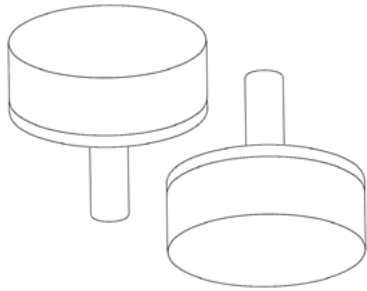

Threaded Rubber  
Isolators  
**(x2)**



3/8" Washers

**(x10)**

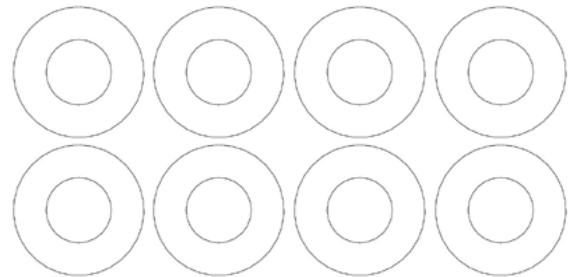

5/16" Washers

**(x8)**

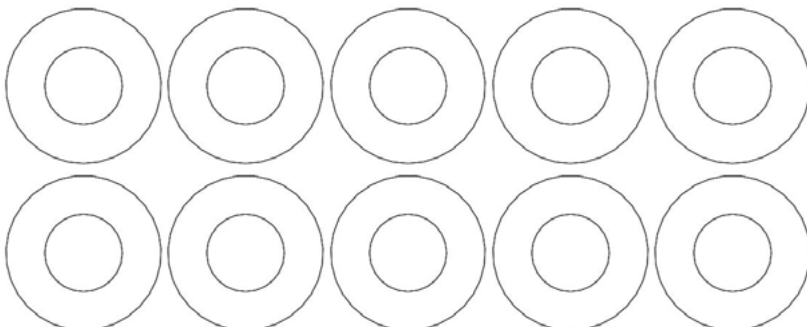

3/8" Nuts  
**(x4)**

