



DESTROYER SERIES
JL JEEP
SPARE TIRE LICENCE
PLATE RELOCATION KIT

INSTALLATION
INSTRUCTIONS



INSTALLATION ON JEEP JL OEM TIRE CARRIER

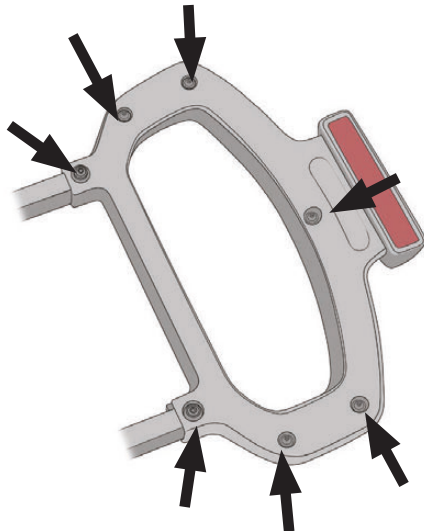

Use a T-25 Torx bit to remove the screws that secure the plastic cover on the tail light hoop.

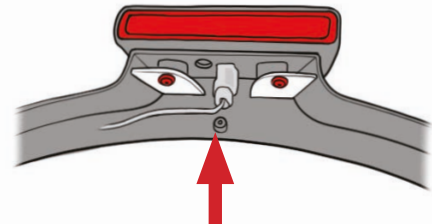

Unplug the light, then remove the cable and light from hoop.

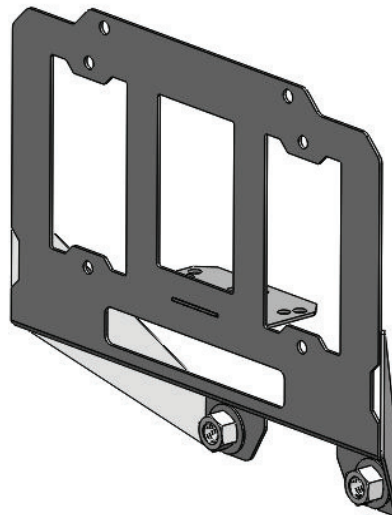

Relocate the 3rd Brake Light to the Spare Tire License Plate Frame using the original screws.

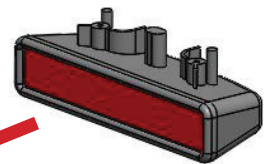

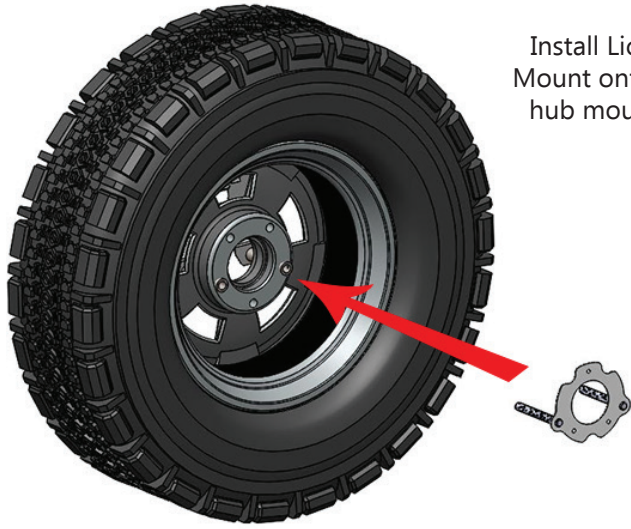

Install License Plate Mount onto the wheel hub mounting face.



Mount your wheel on the carrier and tighten the 3 mounting lug nuts.



Install the Spacer Tubes and the Spare Tire License Plate Frame using 1/2" Hex Nuts and Washers.

Depending on the style of your wheel, you may need to trim the plastic tube spacers to a shorter length.

****Dont Forget to re-route the 3rd Brake Light cable thru the wheel and plug it in!****

Recommended Installation for wiring license plate bolt lights *sold separately*.



Location of rear bumper wire harness plug. Locate license plate light wires and tap into them to extend wiring across the inside of the bumper as shown. You may use the provided wire and butt connectors to make this extension.

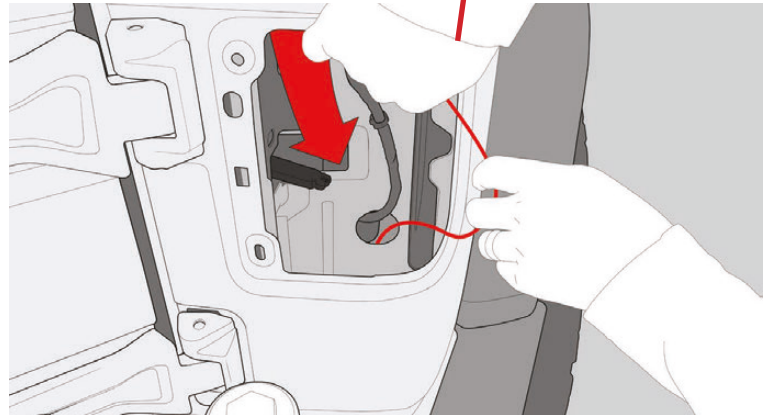

Feed the extension wire from the bumper up through the hole indicated behind the rear tail light on the passenger side.

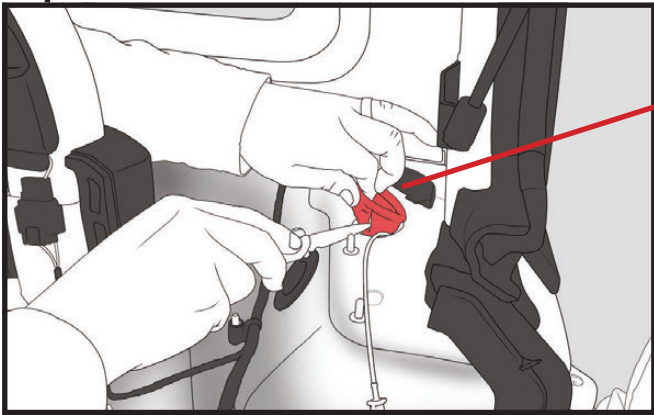
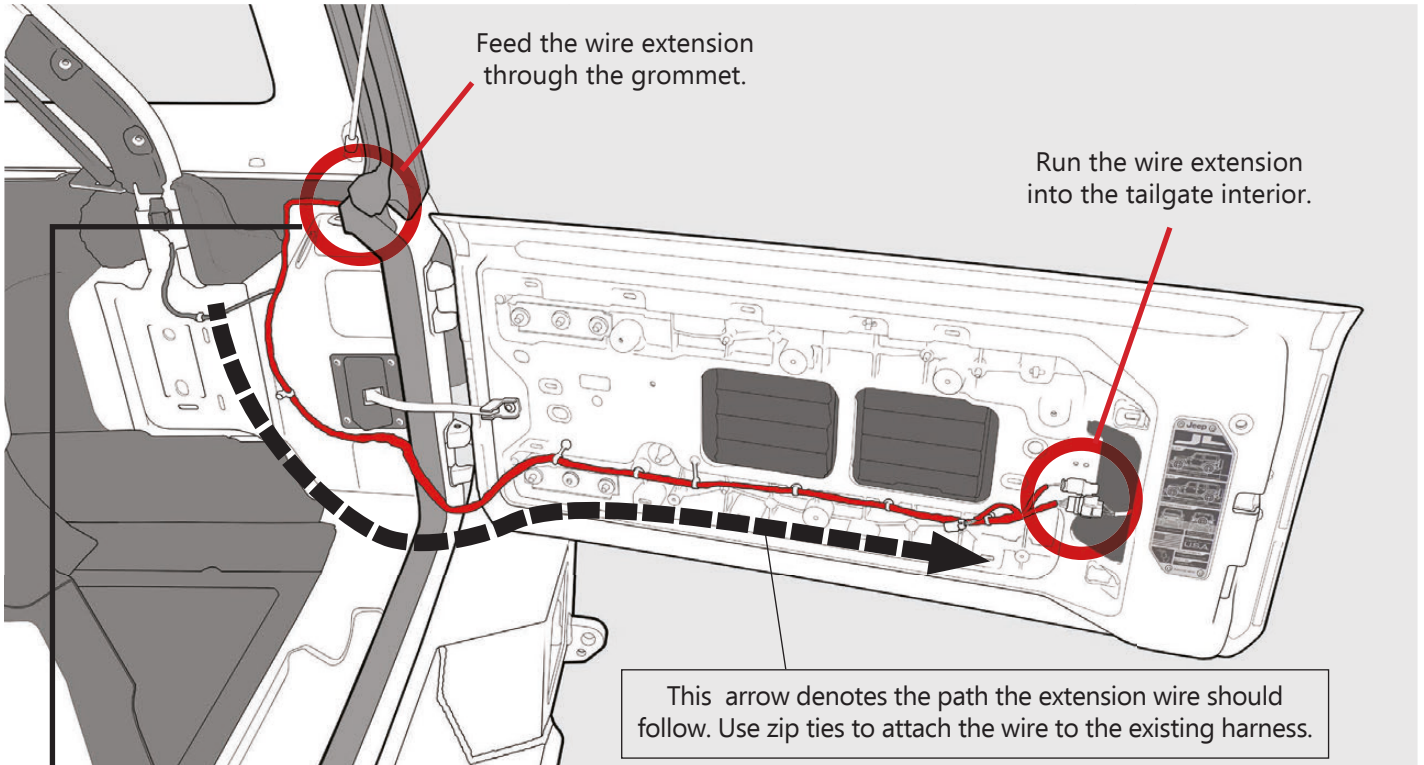

You will need to make an incision/ small hole in the grommet shown (on top) in order to feed the wire extension out of the tail light area.

You can now feed to bolt light wire extension out through the grommet on the tailgate. You will need to make a small hole or cut in the grommet to get the wire out of the tailgate.

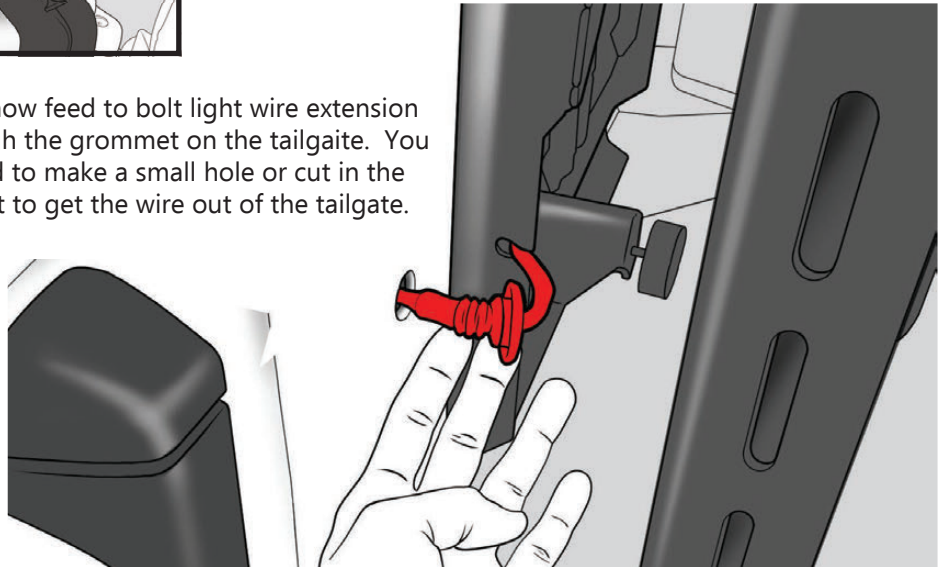

Feed the wire extension through the wheel. Be sure to leave some slack in the wire so you can remove the license plate assembly easily if you need too. You may use the barrel connectors provided with the bolt light kit to complete the installation.



Completed Installation!

INSTALLATION ON JEEP JL DESTROYER TIRE CARRIER

Follow the instructions above for assembling the 3rd Brake Light and the Spare Tire License Plate Frame and install onto your spare tire. Install your spare tire as you normally would onto the Destroyer Tire Carrier and complete the assembly.

TO EXTEND 3RD BRAKE LIGHT WIRING:

Cut the rubber grommet that is attached to the 3rd Brake light wire where it exits the tailgate. Pull the entire wire harness into the tailgate interior and replace the rubber grommet. Cut off the 3rd Brake Light plug. Leave enough wire to allow splice connection later. You can use included butt splice connectors and wire to extend the wiring.

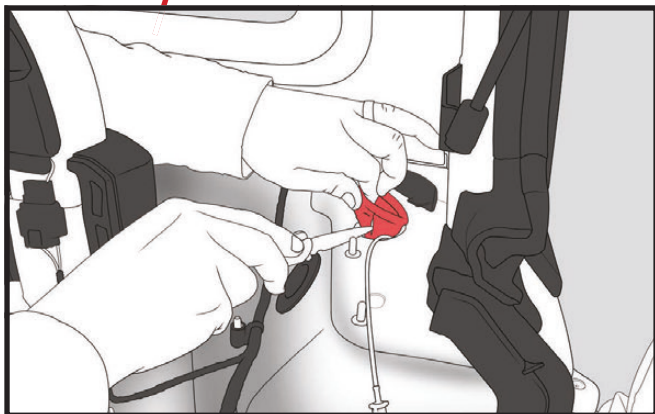
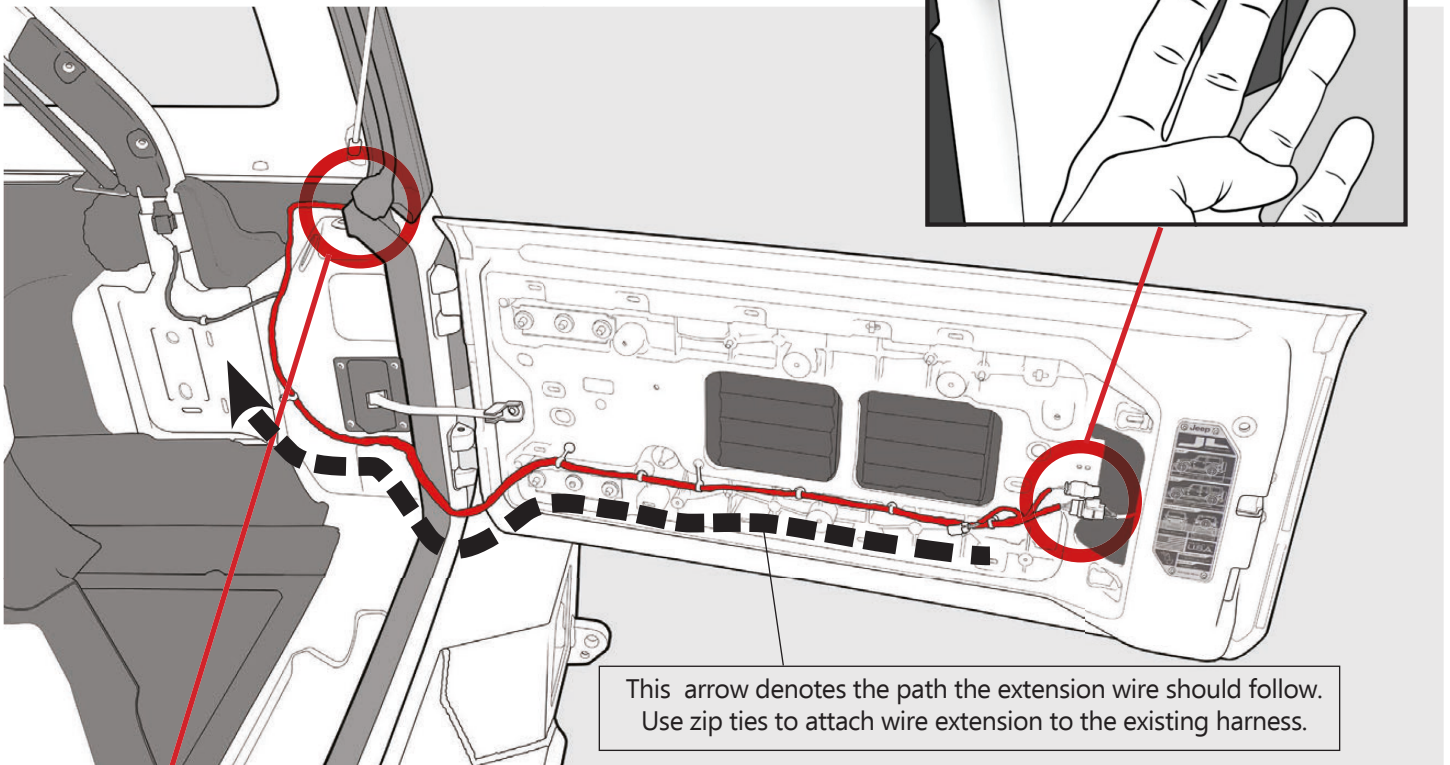
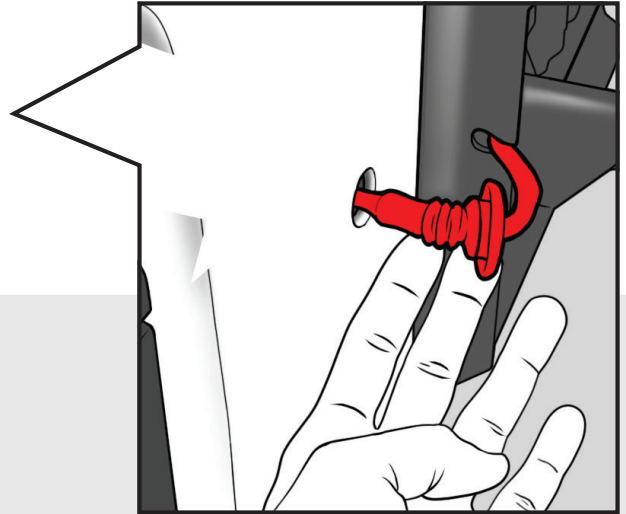

You will need to make an incision/small hole in the grommet shown (on top) in order to feed the wire extension through the tail light area.

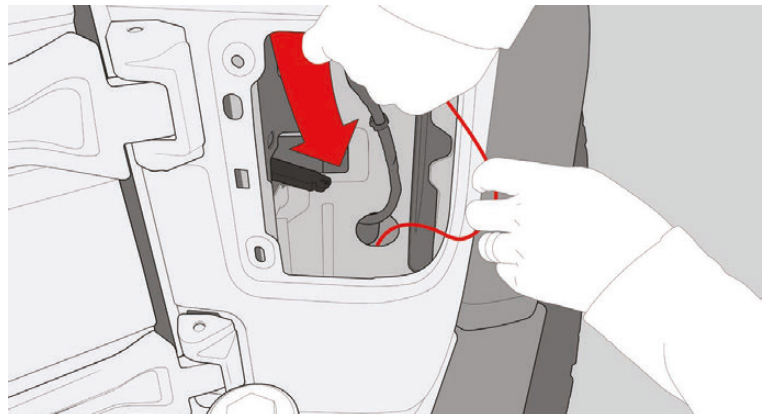

Feed the extension wire down through the hole indicated, you should see the wire come out under the Jeep. You can use a flashlight to help find it.

Recommended Installation for wiring license plate bolt lights *sold separately*.

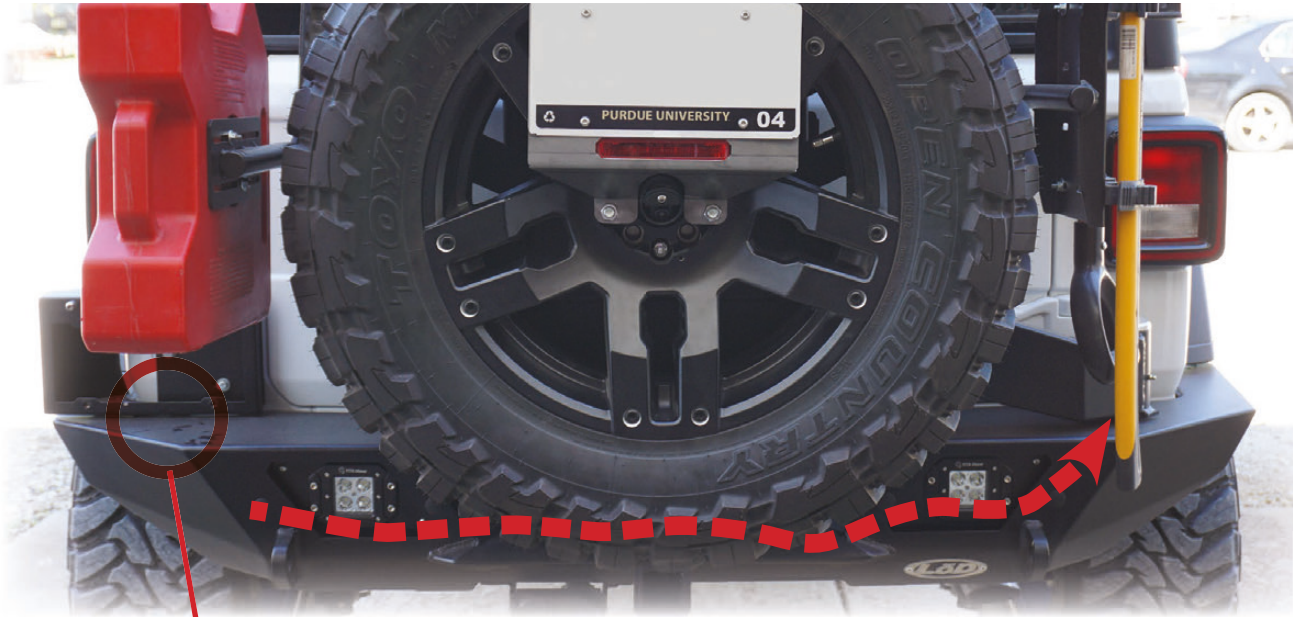

Location of rear bumper wire harness plug. Locate license plate light wires and tap into them to extend wiring across the inside of the bumper as shown. You can use the provided wire and butt connectors to make this extension.

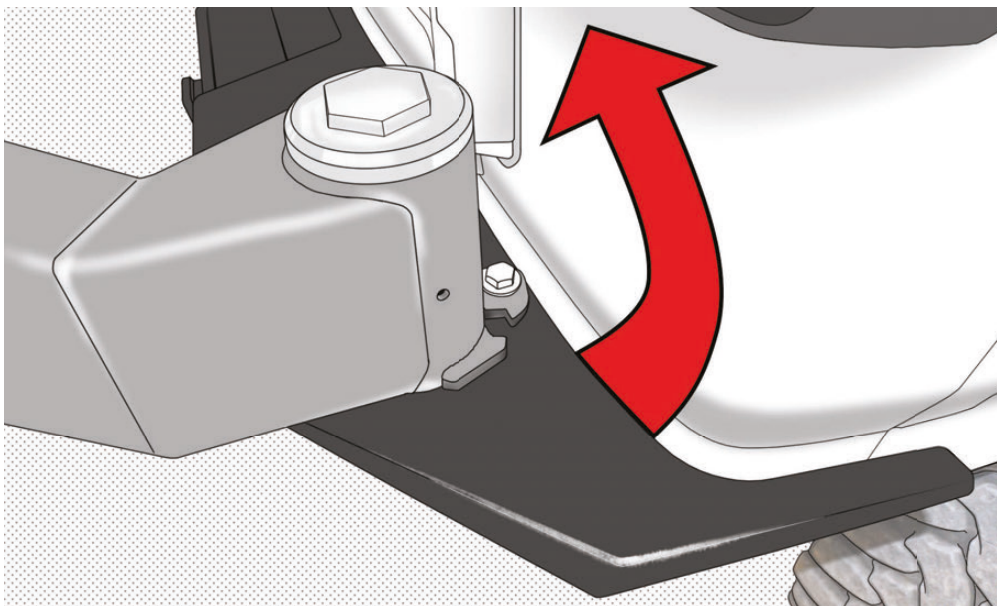

Both 3rd Brake Light and License Plate Light wire extensions should come up between the Jeep and the bumper, close to the base of the swing arm. You can use zip ties to secure the wire extensions under the Jeep and inside the bumper.

****You can run both wire extensions through the provided cable sheathing to help protect against abrasion.****

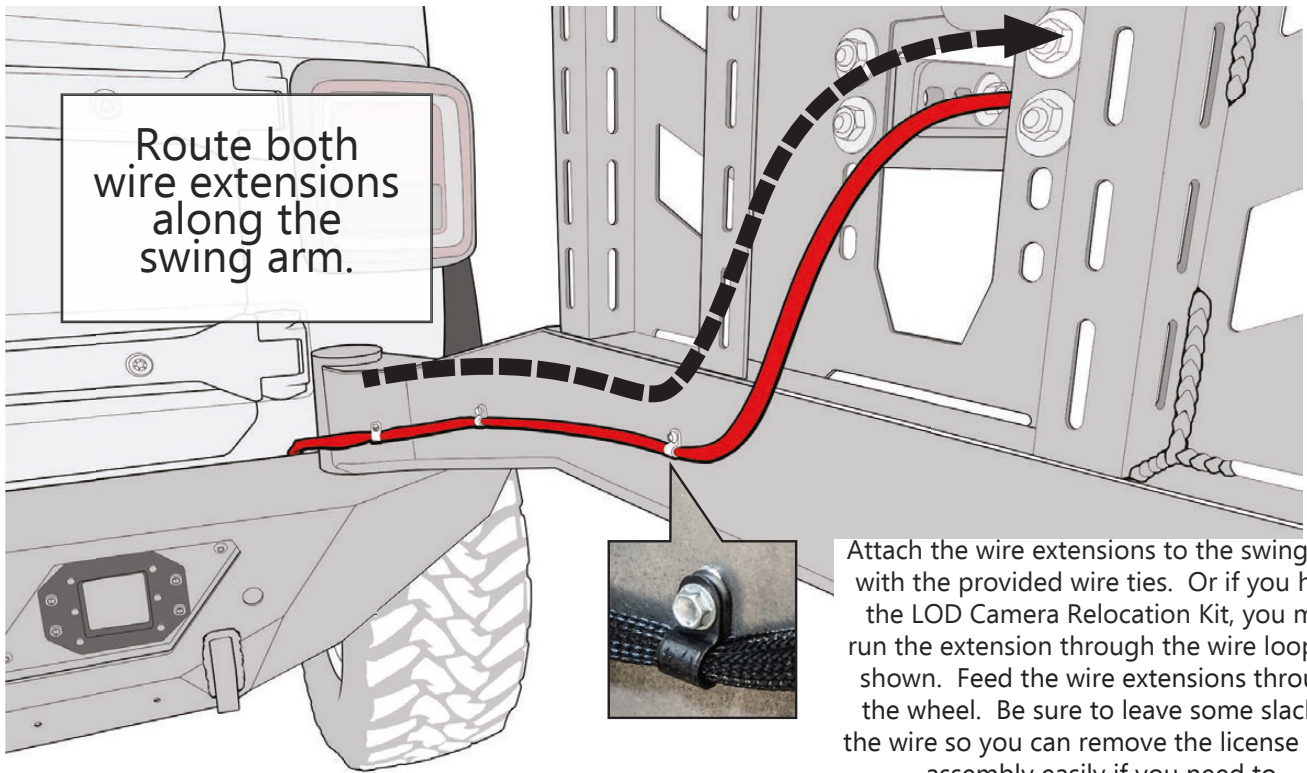

Reconnect the 3rd Brake Light connector to your wire extension using the supplied butt splice connectors and connect your Bolt Lights.



Completed Installation!

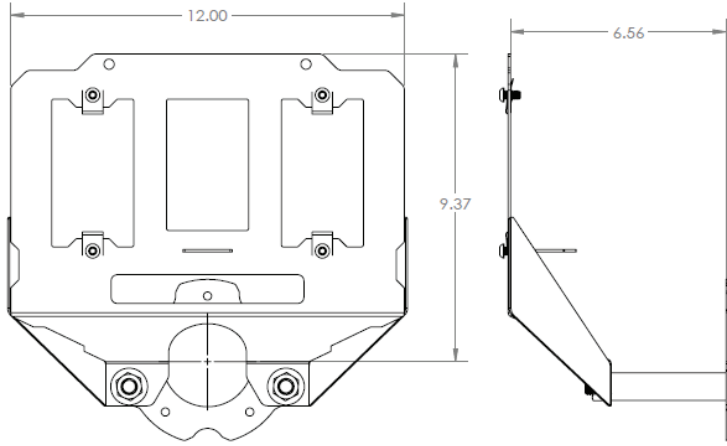
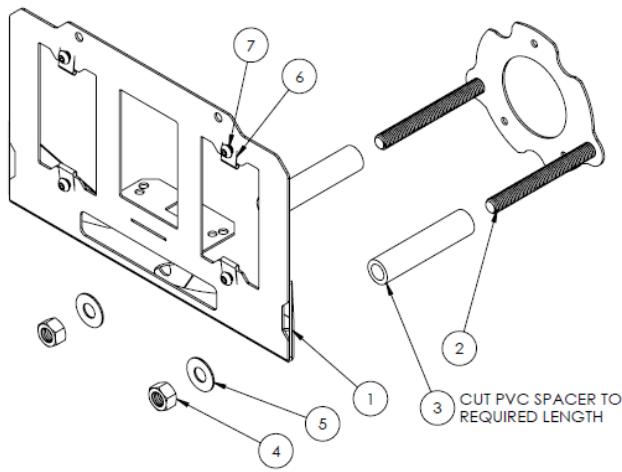

ITEM NO.	PART NUMBER	DESCRIPTION	QTY.
1	4JLP1810-01	JEEP JL SPARE TIRE LICENSE PLATE RELOCATION WELDMENT	1
2	4JLP1810-02	SPARE TIRE LICENSE PLATE MOUNT	1
3	2JLP1810-06	SPACER STANDOFF SCH 80 1/2" PVC X 3.75" LG	2

HARDWARE KIT

ITEM NO.	PART NUMBER	DESCRIPTION	QTY.
4	HN5013ZPGR5	HEX NUT 1/2-13 ZINC PLATE GR5	2
5	FW4318ZP	FLAT WASHER Ø7/16 X 1.25" ZINC PLATED	2
6	CL2520BP	CLIP NUT 1/4-20 STEEL BLACK PHOSPHATE	4
7	BHSCS252008SS	BHSCS 1/4-20 X 0.50 STAINLESS STEEL	4

ITEMS NOT SHOWN

ITEM NO.	PART NUMBER	DESCRIPTION	QTY.
8	CON1004	COOL SEAL BUTT CONNECTOR 16ga	6
9	WT1000	WIRE TIE - BLACK - 5 1/2" LG	10
10	SL1000	EXPANDABLE POLYESTER SLEEVE Ø3/8"	10FT
11	WR1000	18/2 STRANDED WIRE - RED/BLACK	25FT

NOTES:

- JLP1810 = BARE STEEL OPTION
- JLP1811 = BLACK POWDER COAT OPTION

UNLESS OTHERWISE SPECIFIED:		NAME	DATE	LOD LLC.	
DIMENSIONS ARE IN INCHES	DRAWN	MCH	10/31/2016		
TOLERANCES: ±0.010	CHECKED			DESCRIPTION:	
ANGULAR: MAC±0.1°	ENG APPR.			JEEP JL SPARE TIRE LICENSE PLATE RELOCATION KIT	
TWO PLACE DECIMAL ±0.015	MFG APPR.			DWG. NO.	REV
THREE PLACE DECIMAL ±0.005	MATERIAL:			JLP1810	A
PROPRIETARY AND CONFIDENTIAL:	FINISH:			JLP1811	
THE INFORMATION CONTAINED IN THIS DRAWING IS THE SOLE PROPERTY OF LOD LLC. ANY REPRODUCTION IN PART OR AS A WHOLE WITHOUT THE WRITTEN PERMISSION OF LOD LLC IS PROHIBITED.	SEE NOTES			SCALE: 1:3	SHEET SIZE: B
	ECOL:				SHEET 1 OF 1



**JL JEEP
SPARE TIRE LICENCE
PLATE RELOCATION KIT**



Instruction
Booklet

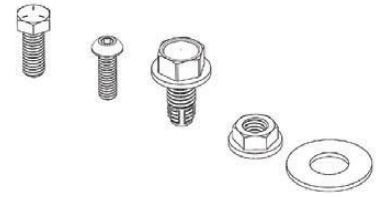

Bolt Kit
(contents may vary)

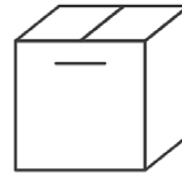

Hardware Kit
(contents
may vary)

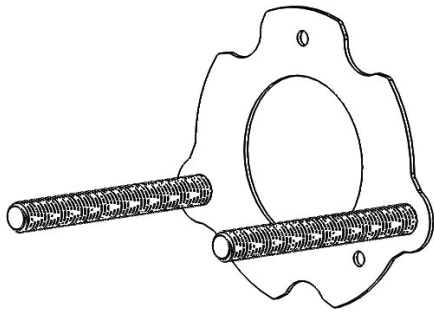

Spare Tire
License Plate
Mount

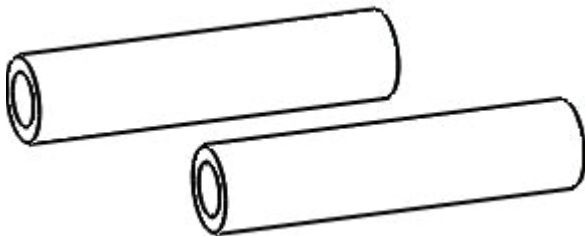

(x2)
Ø1/2" Spacer Tubes
3.75" Long

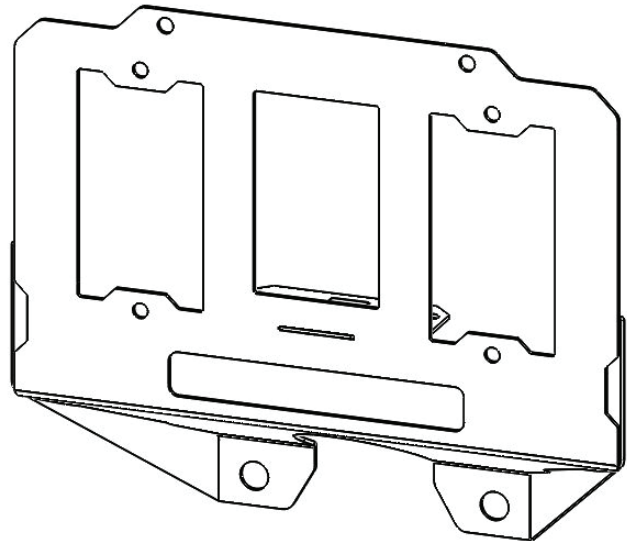

Jeep Spare Tire Relocation
Weldment





JL JEEP
SPARE TIRE LICENCE
PLATE RELOCATION KIT
HARDWARE KIT



(x10)
5.5" Zip Ties



(x6)
16ga Red Butt
Connector



10ft Cable
Sheath



25ft
18/2 Stranded
Red/Black Wire



JL JEEP
SPARE TIRE LICENCE
PLATE RELOCATION KIT
Bolt Kit

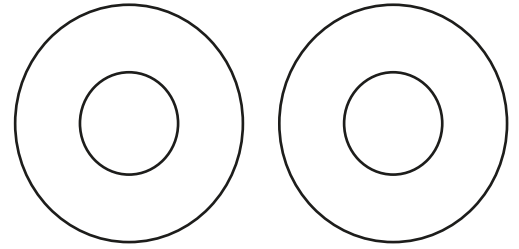

(x2)
Flat Washer
7/16" x 1.25"



(x4)
Clip Nut

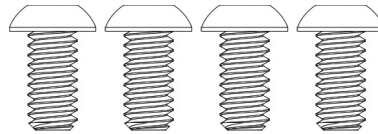
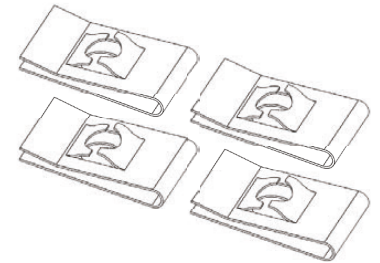

(x4)
Button
Head Screw
1/4-20 x 1/2"

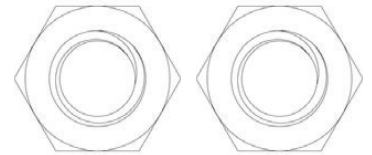

(x2)
Hex Nut
1/2-13

