



DESTROYER SERIES

TRUCK

DODGE 2010+
HEADLIGHT GUARDS



VERIFY YOU HAVE ALL THE COMPONENTS BEFORE STARTING THE INSTALLATION. REFER TO THE ENGINEERING DRAWINGS AT THE END OF THIS DOCUMENT FOR A COMPLETE PARTS LIST



Start by installing your Headlight Guards as shown using the $\text{\O}5/16''$ Carriage Bolts.

Install the 3 Carriage Bolts into the Wing first. Leave these bolts loose while you finish the installation.

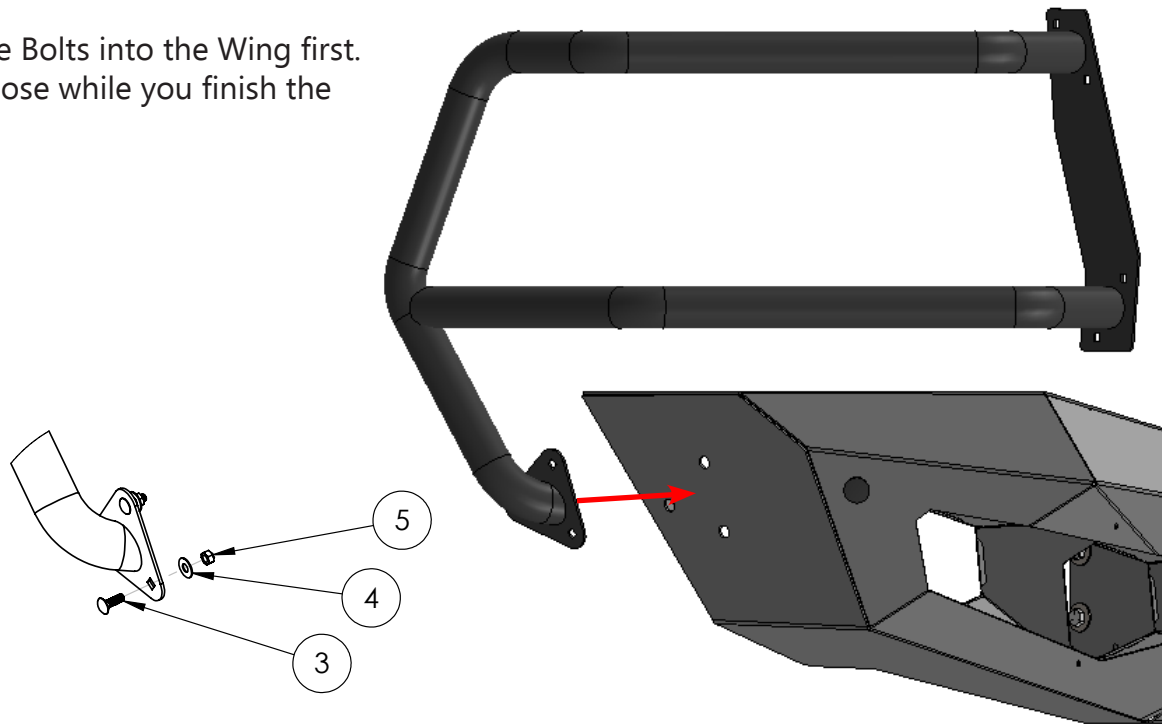

Next install the four Carriage Bolts into the Center Grill Guard as shown. If the bolt holes do not line up correctly you may need to loosen the mounting bolts for your Center Grill Guard.

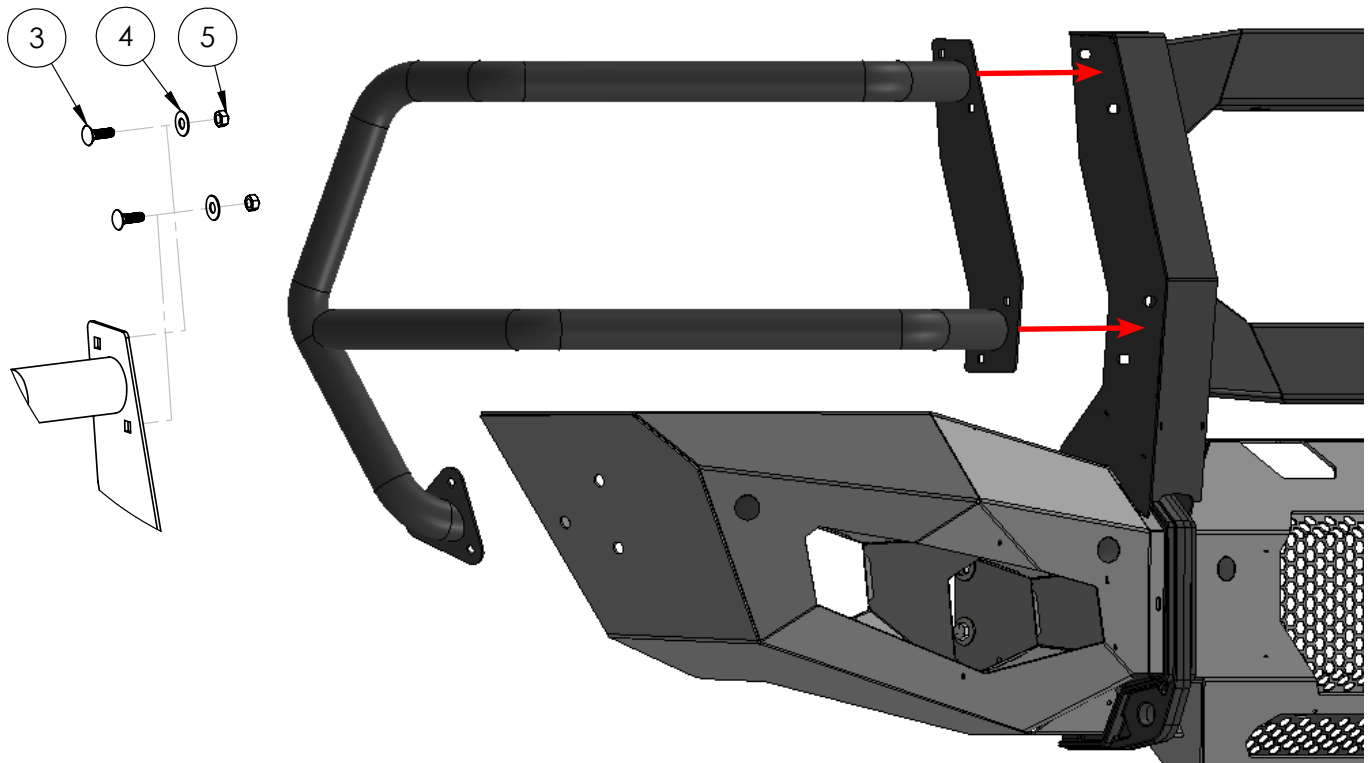

If you are having trouble getting your bolt holes to line up. First start by loosening the two Ø1/2" Hex Bolts that mount your Center Grill Guard.

Be sure to loosen the bolts on both sides of the bumper to allow your Center Grill Guard to move slightly.

This picture shows the Wing removed for clarity. ****Do not remove the Wing.****

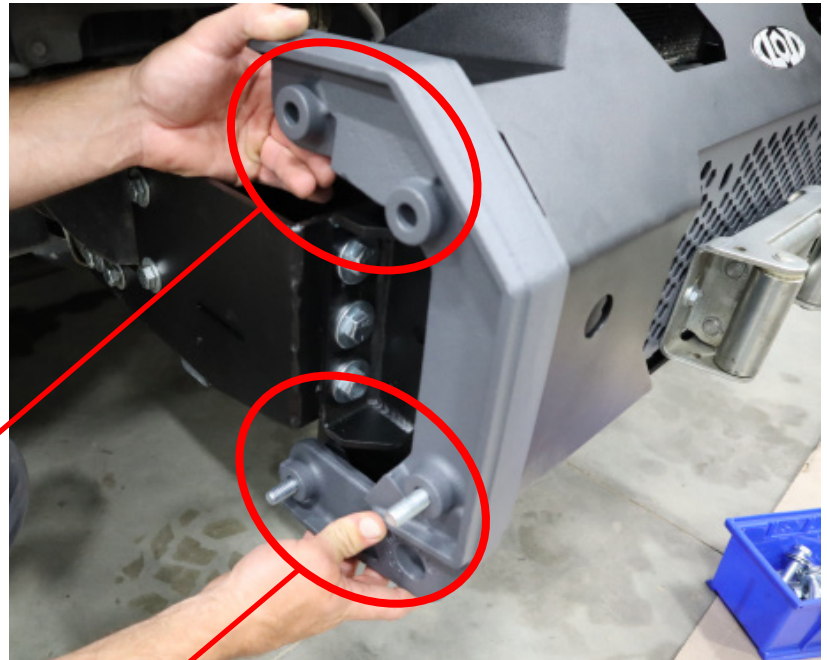

Loosen these two bolts first

Loosen these to adjust the Wing

If your bolt holes still dont line up you may need to adjust the Wing position. With the top two Hex Bolts still loose, loosen the lower two Hex Bolts. This will allow the Wing to shift slightly which should allow you to get all the Carriage Bolts installed.

Once all the Carriage Bolts are installed align your Wing and Center Grill Guard as needed and securely tighten all four Ø1/2" Hex Bolts. Repeat this procedure for both sides of the bumper and then finish tightening the Carriage Bolts.

****Maintenance****

- Periodically check and re-tighten all fasteners.
-
- Periodically check your product for scratches, dings, or rust spots which can happen over time or after heavy use. It is important to address these areas as soon as possible to prevent rust and corrosion from spreading. We recommend using Rustoleum® brand Black Semi-Gloss Protective Enamel (oil based). Apply using a foam brush by dabbing to match the powder coat texture.



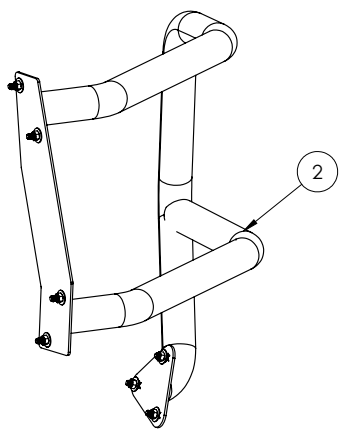
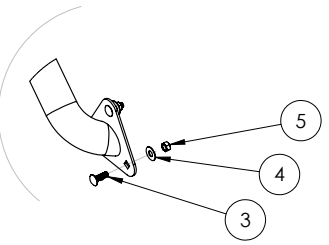
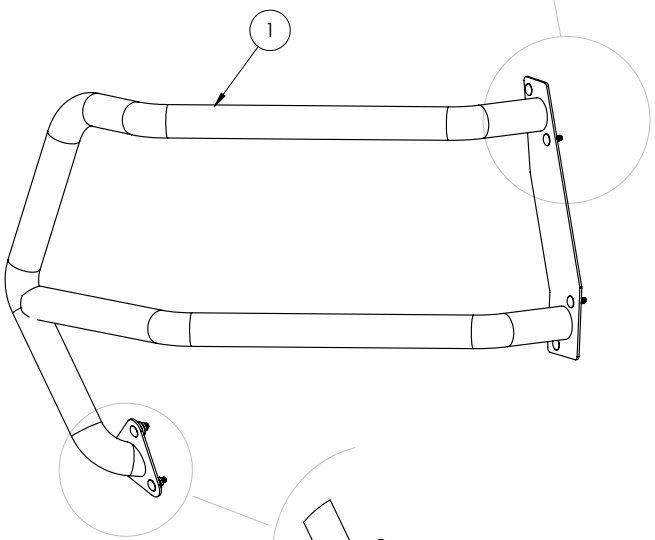
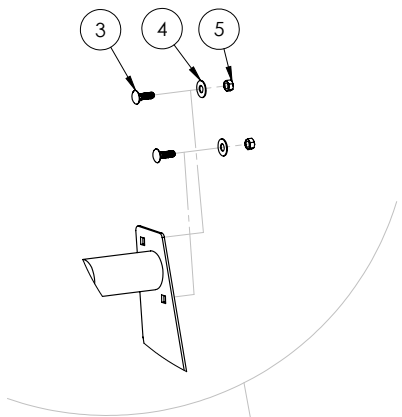

ITEM NO.	PART NUMBER	DESCRIPTION	QTY.
1	4DFB2010-05	DODGE 2010 SIDE GUARD - PS	1
2	4DFB2010-06	DODGE 2010 SIDE GUARD - DS	1

BOLT KIT

ITEM NO.	PART NUMBER	DESCRIPTION	QTY.
3	CB311816ZPGR5	CARRIAGE BOLT 5/16-18 X 1.00 ZINC PLATE GR5	14
4	FW3114ZP	FLAT WASHER Ø5/16" X .875" ZINC PLATE	14
5	HN3118ZPGR5	HEX NUT 5/16-18 ZINC PLATE GR5	14

- NOTES:**
 1. DHG1000 = BARE STEEL OPTION
 2. DHG1001 = BLACK POWDER COAT

UNLESS OTHERWISE SPECIFIED:	NAME	DATE
DIMENSIONS ARE IN INCHES	DRAWN	MCH 9/11/2021
TOLERANCES: +0.010	CHECKED	
ANGULAR: MACH ±1°	ENG APPR.	
TWO PLACE DECIMAL ±0.015	MFG APPR.	
THREE PLACE DECIMAL ±0.005		
PROPRIETARY AND CONFIDENTIAL	MATERIAL:	
THE INFORMATION CONTAINED IN THIS DRAWING IS THE SOLE PROPERTY OF LOD LLC. ANY REPRODUCTION IN PART OR AS A WHOLE WITHOUT THE WRITTEN PERMISSION OF LOD LLC IS PROHIBITED.	FINISH:	SEE NOTES
	ECO:	-

LOD LLC. 

DESCRIPTION:
DODGE 2010 HEADLIGHT GUARDS

DWG. NO. **DHG1000**
DHG1001

SCALE: 1:7 SHEET SIZE: B SHEET 1 OF 1

REV **A**



TRUCK
DESTROYER SERIES
DODGE 2010+
HEADLIGHT GUARD
DRIVER SIDE
4DFB2010-06
SHIPPING SHEET

Packaged by:

On:

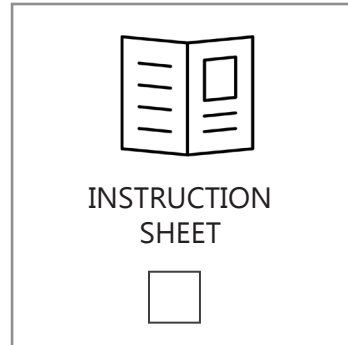

DODGE 2010+ SIDE GUARD - DS
4DFB2010-06
(x1)

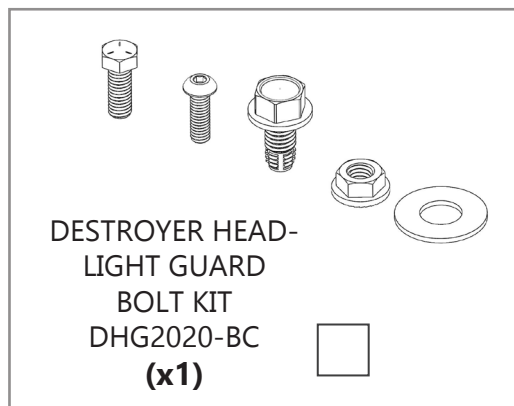
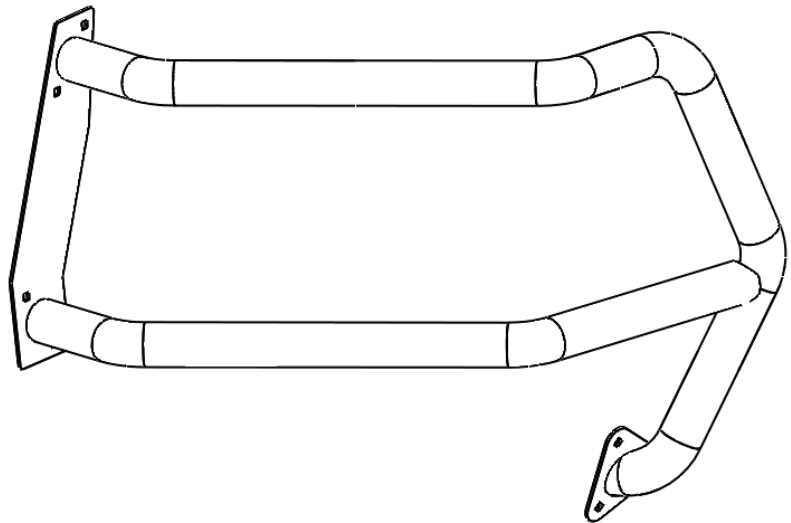



TRUCK
DESTROYER SERIES
DODGE 2010+
HEADLIGHT GUARD
PASSENGER SIDE
4DFB2010-05
SHIPPING SHEET

Packaged by:

On:

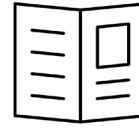

INSTRUCTION
SHEET



DODGE 2010+ SIDE GUARD - PS
4DFB2010-05
(x1)

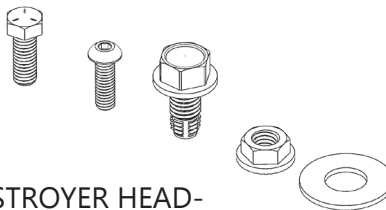
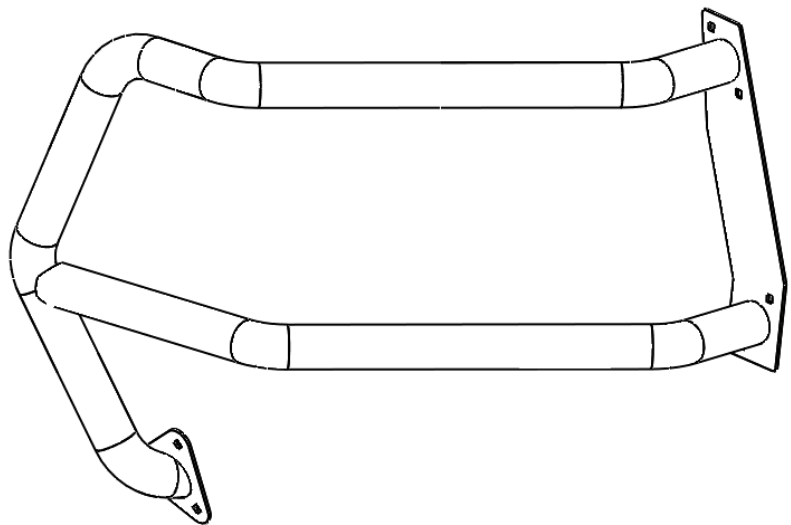

DESTROYER HEAD-
LIGHT GUARD
BOLT KIT
DHG2020-BC
(x1)





TRUCK
DESTROYER SERIES
HEADLIGHT GUARD
Bolt Kit
DHG2020-BC
Packaged by:

On:

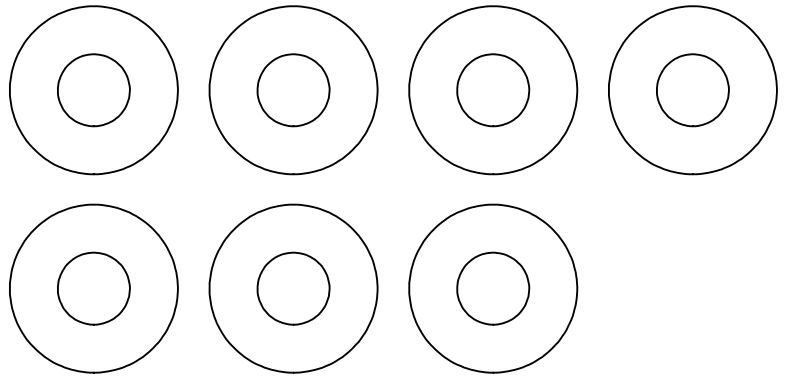

FLAT WASHER
Ø5/16" X .875"
(0159722)
(x7)

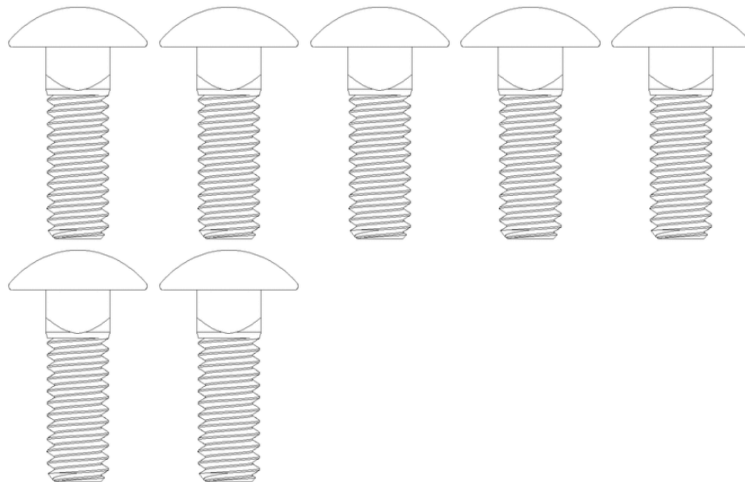

CARRIAGE BOLT 5/16-18 X 1.00
(x7)

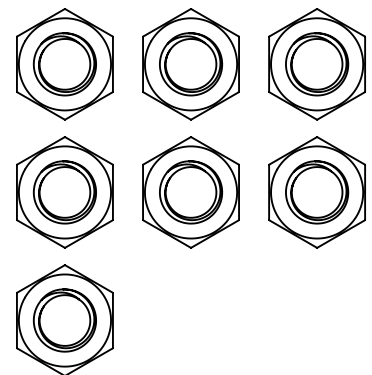

HEX NUT 5/16-18
(0147965)
(x7)

