

LIQUIDYNAMICS Oil Extractors

Instruction & Parts Manual



Model 24224T
6 gallon
Oil Extractor



Model 24270
21 gallon
Oil Extractor



Model 24271
21 gallon Oil Extractor w/
transparent bowl



Model 24272
21 gallon
Oil Extractor w/ Drain



Model 24273
21 gallon Oil Extractor w/
transparent bowl & drain

⚠ WARNING

These extractors are not for use with flammable, explosive or corrosive products such as gasoline, diesel fuel or chemicals.



WARNING

This symbol indicates a potentially hazardous situation which, if not avoided, could result in death or serious injury.



CAUTION

This symbol indicates a potentially hazardous situation which, if not avoided, may result in injury or damage to equipment.

WARNING

Equipment Misuse Hazard

- Equipment misuse can cause the equipment to malfunction, rupture or explode and result in serious injury or death.
- This equipment is for professional use only.
- Read all instructions, manuals, tags and decals before operating equipment.
- Use the equipment only for its intended purpose.
- Do not alter or modify this equipment. Use only genuine Liquidynamics replacement parts.
- Check equipment daily. Repair or replace worn or damaged parts immediately.
- Do not exceed the maximum working pressure of the system. The tank is equipped with a safety relief valve set at 15 PSI. Do not attach an air supply unless regulated to 15 PSI or less.
- Use only with fluids for which the equipment was intended, i.e.; engine and gear oils, transmission fluid, hydraulic fluid and anti freeze.
- Comply with all applicable local, state and national fire and safety regulations.

Technical Data:

Model	24224T	24270	24271	24272	24273
Tank Capacity	6 gal.	21 gal.	21 gal.	21 gal.	21 gal.
Clear Bowl Capacity	–	–	2 gal.	–	2 gal.
Drain Bowl Capacity	–	–	–	25 qts.	25 qts.
Maximum Working Height	–	–	–	64"	64"
Minimum Working Height	–	–	–	49"	49"
Suction Hose Length	12 ft.	12 ft.	12 ft.	12 ft.	12 ft.
Discharge Hose Length	N/A	6 ft.	6 ft.	6 ft.	6 ft.
Oil Suction Capacity per charge	4 gal.	14 gal.	14 gal.	14 gal.	14 gal.
Approximate Vacuum charging Time w/ 100-psi shop air.	45 sec.	3 min.	3 min.	3 min.	3 min.
Approximate suction rate with 0.24" (6mm) dia. Probe with hot engine oil @ 158° to 176° F.	0.5 gal/min	0.5 gal/min	0.5 gal/min	0.5 gal/min	0.5 gal/min

Introduction:

These fluid extractors have been designed to remove motor oil, transmission fluid, antifreeze, gear oil and similar fluids from automobiles, trucks, buses, boats, forklifts and gearboxes.

WARNING

To avoid personal injury or death, do not use these extractors with flammable, explosive or corrosive products such as gasoline, diesel fuel or chemicals. Do not do any welding on the reservoir.

CAUTION

While draining high temperature oils, keep hands, exposed skin and face protected. Only use the device for the purpose for which it has been designed. Do not modify any components of the equipment. Use only original spare parts.

Standard Equipment:

Each model is provided with six probes as detailed in Fig. 1a. The standard hose connector, indicated as item A in Figure 1, is suitable for use with Mercedes Benz engines.

Additionally, three adapters are provided for use with Volkswagen, BMW and Citrone engines. Use of these adapters is illustrated in Figure 1.

Optionally, three adapters for use on marine engines are available as follows:

1. P/N 900199 Mastercraft engine adapter
2. P/N 900210 OMC engine adapter
3. P/N 900235 Outboard engine lower lube fitting



Note:

Some engines have the oil dip tubes incorporated to the bottom of the engine crankcase. When this is the case, connect the oil extractor probe (item A, figure 1) directly to the oil dip tube of the engine (Mercedes Benz). Alternatively use the adapters (item B, C & D,

figure 1) to connect the oil extractor probe (item A) to the engine (B-Volkswagen, C-BMW, D-Citrone). For engines that do not incorporate the oil dip tube to the bottom of the engine, use one of the six probes provided. Always use the largest diameter and shortest length probe possible to minimize extraction times.

The following probes are supplied with extractor as standard equipment:

Probe P/N	Diameter	Length	Material
P/N 24304	0.20 in. (5 mm)	27.5 in. (700 mm)	Flexible
P/N 24305	0.20 in. (5 mm)	27.5 in. (700 mm)	Metal
P/N 24306	0.24 in. (6 mm)	27.5 in. (700 mm)	Metal
P/N 24316	0.24 in. (6 mm)	27.5 in. (700 mm)	Flexible
P/N 24307	0.28 in. (7 mm)	39.4 in. (1000 mm)	Flexible
P/N 24308	0.32 in. (8 mm)	27.5 in. (700 mm)	Flexible

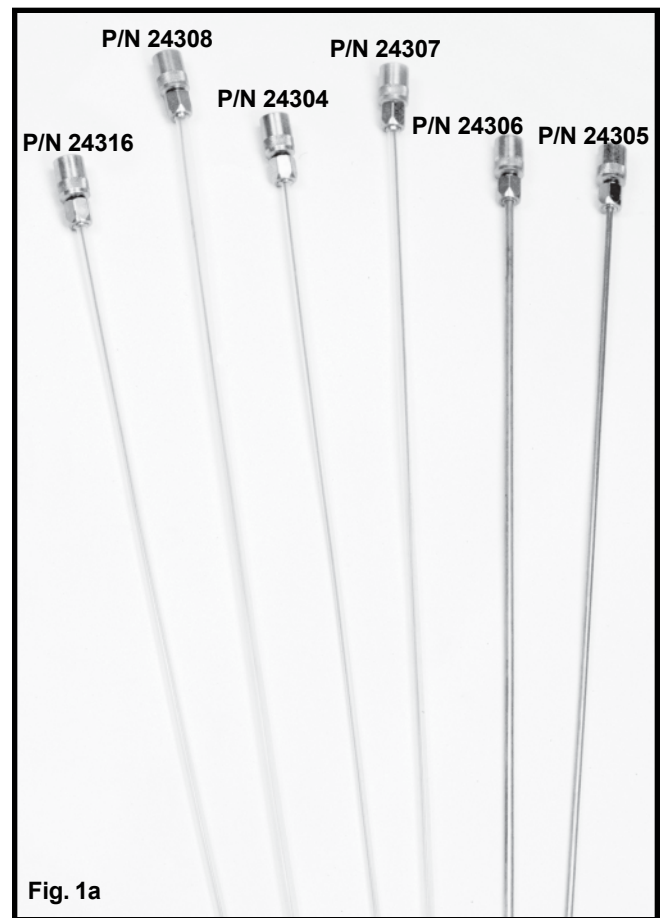
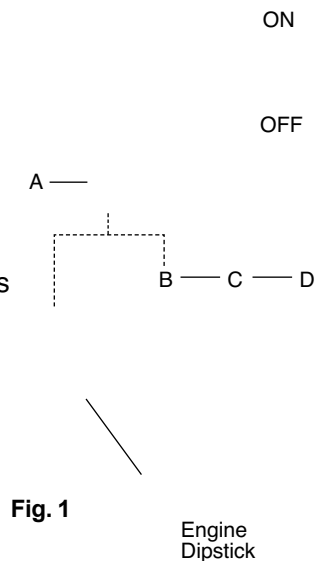

Optional available probes:

Probe P/N	Diameter	Length	Material
P/N 24310	0.20 in. (5 mm)	59 in. (1500 mm)	Flexible
P/N 24426	0.24 in. (6 mm)	59 in. (1500 mm)	Flexible
P/N 24427	0.28 in. (7 mm)	59 in. (1500 mm)	Flexible
P/N 24428	0.31 in. (8 mm)	59 in. (1500 mm)	Flexible
P/N 24450	0.47 in. (12 mm)	27.5 in. (700 mm)	Flexible

Assembly:

Model 24224T 6 Gallon Extractor

Step 1. Attach a 1/4" NPT male air chuck fitting 'F' (not provided) to the air inlet side of the venturi assembly as shown in (figure 3.)

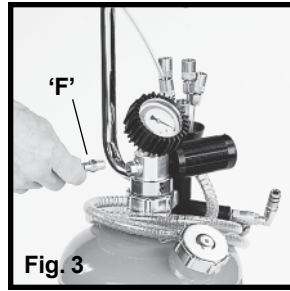

Model 24270 21 Gallon Extractor

Step 1. Insert the handle as illustrated in (figure 4) and tighten the 3 mm Allen head screws until snug.

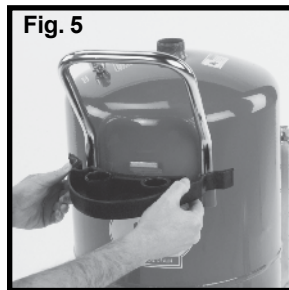

Step 2. Place the tool tray on the bracket provided by pushing the bracket firmly against the reservoir (figure 5) and then down onto the bracket. It may be necessary to use a mallet to gently tap the tray into

place. Place the suction probe container ('B') in the right hand opening, taking care to allow the bottom of the probe container to fit into the opening provided (figure 6).

Step 3. Attach the discharge drain hose ('C') as shown in (figure 6) and tighten the hose clamp securely with a flat head screw driver.

Step 4. Attach a 1/4" NPT male air chuck fitting 'F' (not provided) to the air inlet side of the venturi assembly as shown in (figure 3).

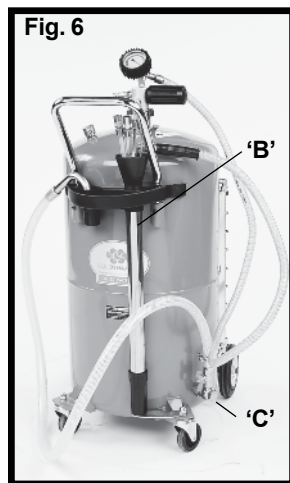

Model 24271 21 Gallon Extractor w/ Transparent Bowl

Step 1. Follow steps # 1 through # 3 shown for model 24270.

Step 2. Position the transparent bowl 'D' onto the reservoir as shown in (Figure 7) make sure that the transparent bowl seats fully and securely onto the reservoir tank. Tighten the retaining ring nut 'E' using a suitable tool (spanner wrench or large slip joint pliers.)

Step 3. Attach a 1/4" NPT male air chuck fitting 'F' (not provided) to the air inlet side of the venturi assembly located at the top of the transparent bowl (Figure 7).

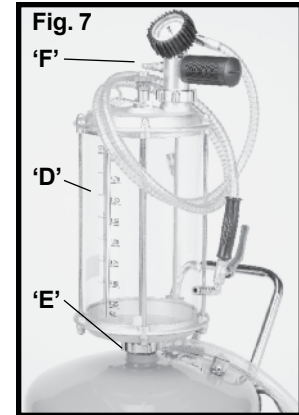

Model 24272 21 Gallon Extractor w/Drain Bowl

Step 1. Follow steps # 1 through 4 shown for Model 24270.

Step 2. Attach the riser tube assembly to the drain pan (figure 8) and tighten snugly with a 1 1/2" open-end wrench.

Step 3. Attach drain pan/riser tube assembly to reservoir as shown in (figure 9), secure at desired height by hand tightening the compression wing nut 'G'.

Step 4. Attach drain pan drain hose 'H' to riser tube and tank fitting and secure with band clamps provided.

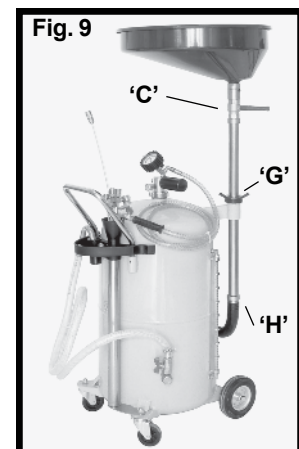
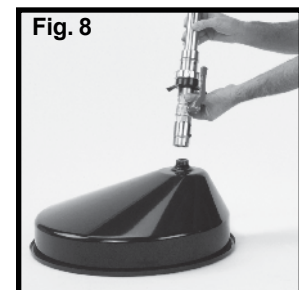

Model 24273 21 Gallon Extractor w/ Drain Bowl & Transparent Bowl

Step 1. Follow steps # 1 through # 3 shown for Model 24270, steps #2 and 3 for Model 24271 and steps # 2 through # 4 for Model 24272.

Vacuum Charging

Note: An air supply capable of supplying approximately 25 CFM for the times noted below is required for proper operation.

Note: Using an air supply pressure significantly less or more than 100 PSI will adversely effect vacuum created in tank.

Model 24224T

6 Gallon Oil Extractor

Step 1. Make sure suction valve 'A' is closed and drain cap B is tightened snugly (figure 10).

Step 2. Connect a compressed air hose with approximately 100 psi to quick coupler 'C'. Air will escape through muffler 'M' (figure 10).

Step 3. Leave air connected until vacuum gauge approaches the "red" area on dial. This will take approximately 45 seconds. Disconnect the air supply once the vacuum charge has been achieved.

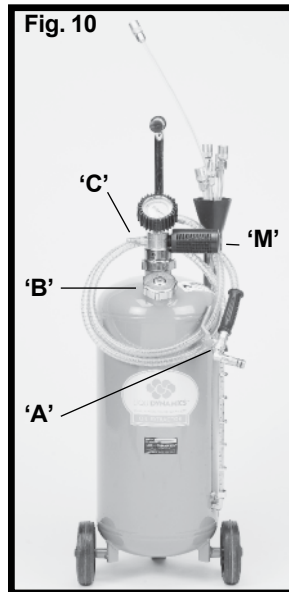

Model 24270 and 24272

21 Gallon Extractor with and without Drain Bowl

Step 1. Make sure suction valve 'A', discharge valve 'B' (figure 11) and oil drain valve 'C' (figure 9, Model 24272 only), are closed.

Step 2. Open venturi valve 'D' (figure 12) (turn fully counter clockwise).

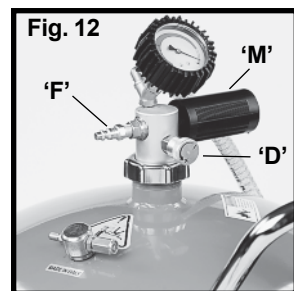

"red" area on dial. This will take approximately 2½ to 3 minutes. Disconnect air supply once vacuum charge has been achieved.

Step 3. Connect a compressed air hose with approximately 100-psi pressure to the quick coupler fitting 'F' (figure 12). Air will escape through muffler 'M' (figure 12).

Step 4. Leave air connected until vacuum gauge approaches the

Model 24271 and 24273

21 Gallon Oil Extractor w/Transparent Bowl & 21 Gallon Oil Extractor w/Drain Bowl & Transparent Bowl

Step 1. Make sure suction valve 'A', discharge valve 'B' and Oil Drain Valve 'C' (Figure 14) (Model 24273 only) are closed.

Step 2. Open Vacuum Valve D (Figure 15) by turning counterclockwise until fully open.

Note: By opening vacuum valve 'D' (Figure 15) a vacuum will be created both in the reservoir tank as well as in the transparent bowl. If a vacuum is desired only in the transparent bowl, leave valve 'D' in the closed position (clockwise).

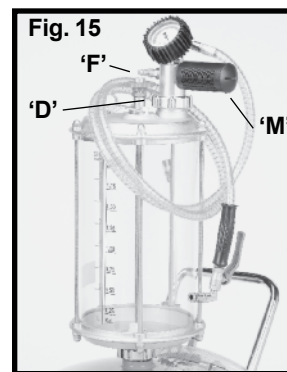
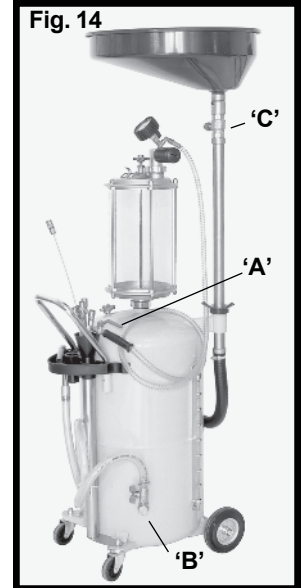

Step 3. Connect a compressed air hose with approximately 100-psi pressure to the quick connect coupler fitting 'F' (Figure 15). Air will escape through muffler 'M' (Figure 15).

Step 4. Leave air connected until vacuum gauge approaches the "red" area on the dial. This will take approximately 15 seconds for transparent bowl only or 3 min. for tank and bowl. Disconnect air supply once vacuum charge has been achieved.

Extracting Oil from Engine:

Note: Always extract hot oil. This temperature is specified at 150° to 176°F (70° to 80° C).

CAUTION

While extracting high temperature oils, keep hands and face protected with impermeable gloves and face shield.

Note: The suction capacity of each oil extractor is equal to approximately two-thirds of the models total tank capacity. Specific tank capacity of each model is given in the Technical Data at the beginning of this manual.

Step 1. Working with a hot engine, remove the dipstick and insert a suitable suction probe using the largest diameter possible (in the case of some Mercedes Benz, BMW, VW and Citrone engines use the appropriate adapters supplied).

Push the suction probe down into the dipstick tube to the bottom of the sump. Connect the suction hose to the suction probe, (Figure 16 and 17).

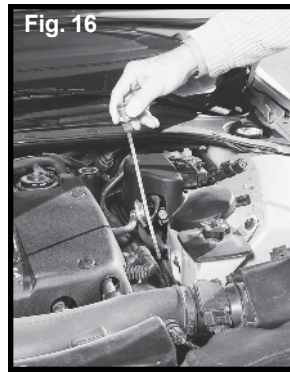

Note: A small wire at the end of the probe ensures ample clearance and prevents restricting the end of the probe at the bottom of the engine sump.

Step 2. Open valve 'B' (Figure 17) at the end of the suction hose. Oil is sucked from the sump into the Oil Extractor reservoir tank (or transparent bowl). The transparent bowl allows you to check oil quantity and quality.

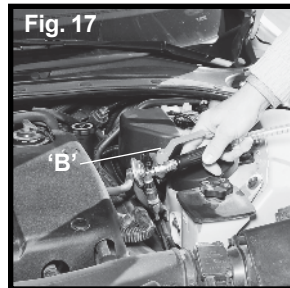

To Prevent neutralizing the vacuum charge, close valve 'B' as soon as possible after air is heard, or observed, in the suction line. Allow the oil to "pool" for 15-20 seconds and again open valve B briefly to extract all free oil from the engines sump.

Note: If valve 'B' is not closed promptly, you will need to charge the vacuum again for proper operation.

Step 3. For models 24271 and 24273 (with transparent bowls), first open valve 'D' (turn fully counter clockwise) and then press down on vacuum valve 'D' (Figure 15) to let oil drain from the transparent bowl into the tank.

Proper Operation:

For proper operation, care should be taken to keep oil out of the venturi and muffler. Oil can easily get into the venturi and muffler in any of the following situations:

1. Do not fill above the tank or transparent bowl "STOP" indicator (Figure 18).
2. Make sure that valve 'D' is open before oil is drained from the transparent bowl to the lower tank (Figure 15).
3. Always empty the unit before moving. When the tank or transparent bowl are full, oil can easily splash into the venturi.
4. Drain oil from the transparent bowl into the reservoir tank while the oil is hot.



Emptying Tank

Model 24224T

6 Gallon Oil Extractor (Emptied by hand)

Step 1. Manually drain the unit by opening the suction valve 'A' to neutralize the vacuum charge and then remove cap 'T' (Figure 19).

Note: If the cap 'T' is removed prior to neutralizing the vacuum it is possible to suck the cap gasket into the tank.

Step 2. Lift the tank and carefully tip to allow oil to flow into receiving reservoir. Take care not to tip tank excessively causing oil to flow into the venturi assembly.

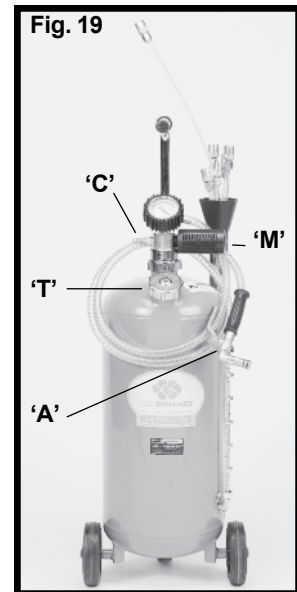

Model 24270 & 24272

21Gallon Extractor (without transparent bowl)

Step 1. Make sure suction valve 'A', discharge valve 'B' (Figure 11) and oil drain valve 'C' (Figure 9) (model 24272) are closed.

Step 2. Close venturi valve 'D' (figure 12) by turning fully clockwise. This isolates the venturi from the tank thus allowing the tank to be pressurized.

Step 3. Connect a compressed air hose supply at the Schrader Valve 'J' and charge to approximately 7-10 psi via a regulated air supply (figure 20). Place the discharge hose securely into a receiving container and slowly open discharge valve 'B' (figure 11).

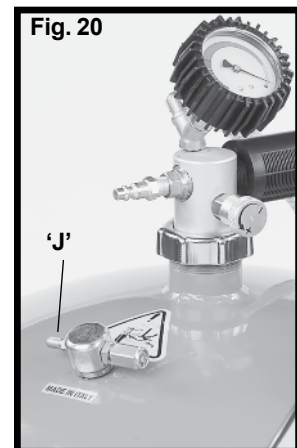

Model 24271 & 24273

21Gallon Oil Extractor (with transparent bowl)

Step 1. Same as for models 24270 and 24272 above.

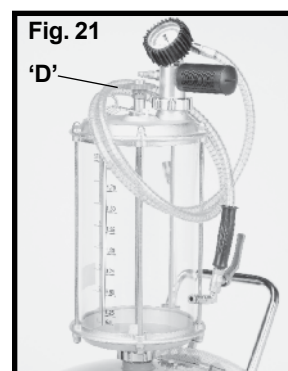

Step 2. Close vacuum valve 'D' by turning fully clockwise (this isolates the transparent bowl from the tank thus allowing the tank to be pressurized (Figure 21).

Step 3. Same as for models 24270 and 24272 above.

Model 24224T

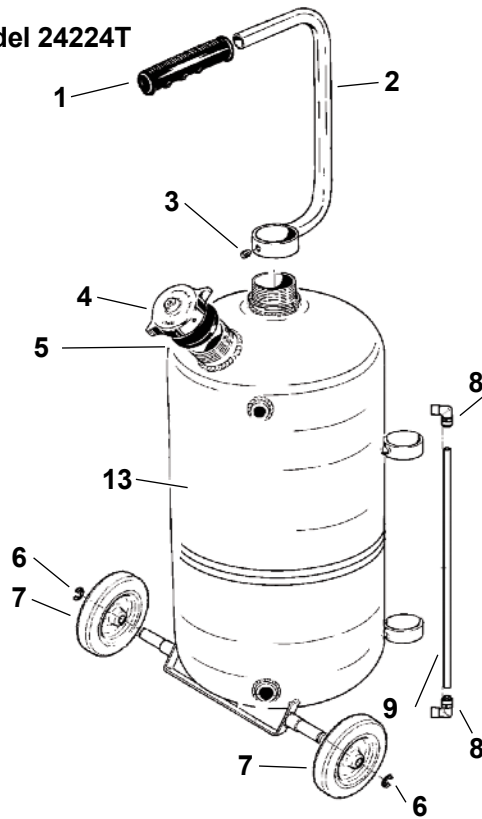

Exploded Parts Items (Drain Pan Assembly):

1	P/N S3150	Grip, handle
2	P/N S3151	Handle, carry
3	P/N S3152	Set screw, carry handle
4	P/N S3153	Cap, drain
5	P/N S3154	Gasket, drain cap
6	P/N S3155	Retainer, 'C' clip
7	P/N S3156	Wheel, fixed
8	P/N S3244	Fitting, elbow, sight tube
9	P/N S3157	Sight tube, 6 gallon
13	P/N S3159	Tank, 6 gallon

Parts applicable for Models 24270 and 24272

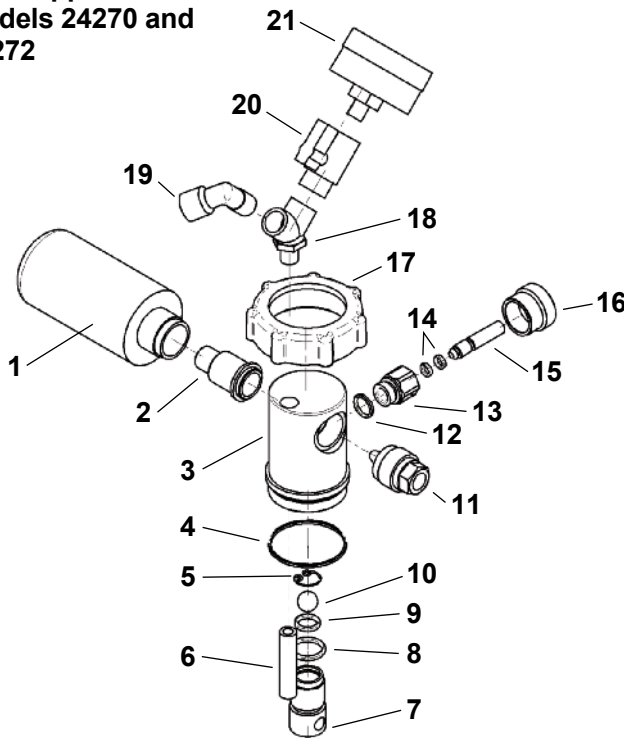

Exploded Parts Items:

Assy	P/N S3301	Venturi Assy for direct mount on tank
1	P/N S3303	Muffler
2	P/N S3304	Exhaust cone, venturi
3	P/N S3305	Housing, venturi
4	P/N S3306	'O' Ring, venturi housing
5	P/N S3307	Clip, retainer, ball check
6	P/N S3308	Tube, breather, venturi
7	P/N S3309	Seat, ball check inlet, venturi
8	P/N S3310	'O' Ring, venturi inlet
9	P/N S3311	'O' Ring, ball check
10	P/N S3312	Ball check, venturi
11	P/N S3313	Cone, inlet, venturi
12	P/N S3314	'O' Ring, isolation valve
13	P/N S3315	Body, isolation valve
14	P/N S3326	'O' Ring, isolation valve stem (2 ea.)
15	P/N S3316	Stem, isolation valve
16	P/N S3317	Knob, isolation valve
17	P/N S3318	Ring Nut, venturi assy.
18	P/N S3319	'Y' fitting, venturi assy.
19	P/N S3320	Fitting, elbow, venturi assy.
20	P/N S3321	Valve, isolation, vacuum gauge
21	P/N S3322	Gauge, vacuum

**Parts applicable for
Models 24224T, 24271 and 24273**

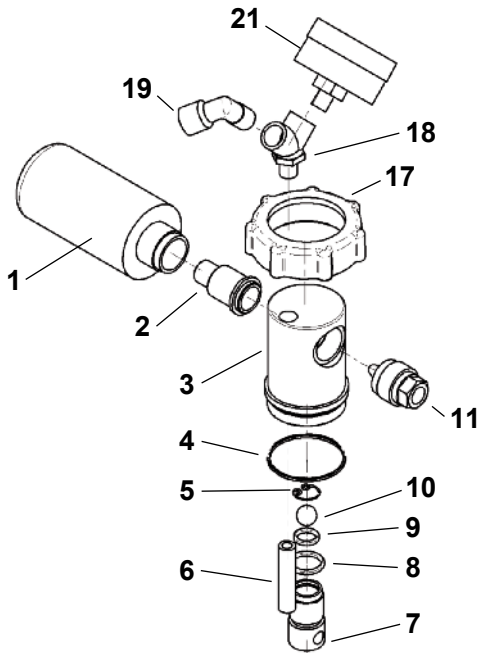

Exploded Parts Items:

Assy P/N S3302	Venturi Assy for use w/ transparent bowl
1	P/N S3303 Muffler
2	P/N S3304 Exhaust cone, venturi
3	P/N S3305 Housing, venturi
4	P/N S3306 'O' Ring, venturi housing
5	P/N S3307 Clip, retainer, ball check
6	P/N S3308 Tube, breather, venturi
7	P/N S3309 Seat, ball check inlet, venturi
8	P/N S3310 'O' Ring, venturi inlet
9	P/N S3311 'O' Ring, ball check
10	P/N S3312 Ball check, venturi
11	P/N S3313 Cone, inlet, venturi
17	P/N S3318 Ring Nut, venturi assy.
18	P/N S3319 'Y' fitting, venturi assy.
19	P/N S3320 Fitting, elbow, venturi assy.
21	P/N S3322 Gauge, vacuum

**Parts applicable for
Models 24270, 24271, 24272
and 24273**

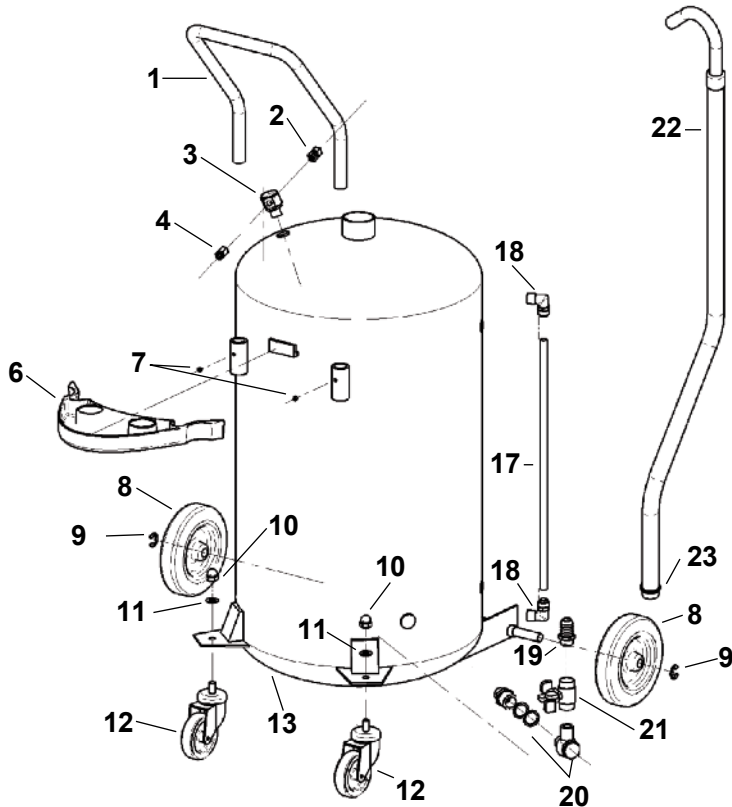

Exploded Parts Items (Tank Assembly):

Assy P/N S3226	Air Valve Assy. (incl. items 2, 3 & 4)
1	P/N S3223 Handle
2	P/N S3224 Schrader Valve Assy.
3	P/N S3227 'T' Fitting
4	P/N S3228 Safety Relief Valve
6	P/N S3231 Tool Tray
7	P/N S3232 Allen Screw, 3 mm
8	P/N S3233 Wheel, fixed
9	P/N S3234 Clip, Retainer
10	P/N S3235 Nut, Acorn
11	P/N S3236 Washer
12	P/N S3237 Caster, Swivel
13	P/N S3238 Tank, Reservoir (24270 & 24271) P/N S3276 Tank, Reservoir (24272 & 24273)
17	P/N S3243 Sight Tube, 21 gal.
18	P/N S3244 Elbow Fitting, Sight Tube
19	P/N S3245 Fitting, Hose
20	P/N S3247 Elbow Assembly
21	P/N S3246 Valve, Discharge
22	P/N S3242 Hose, Discharge
23	P/N 3263 Clamp, Hose

**Parts applicable for
Models 24271 and 24273**

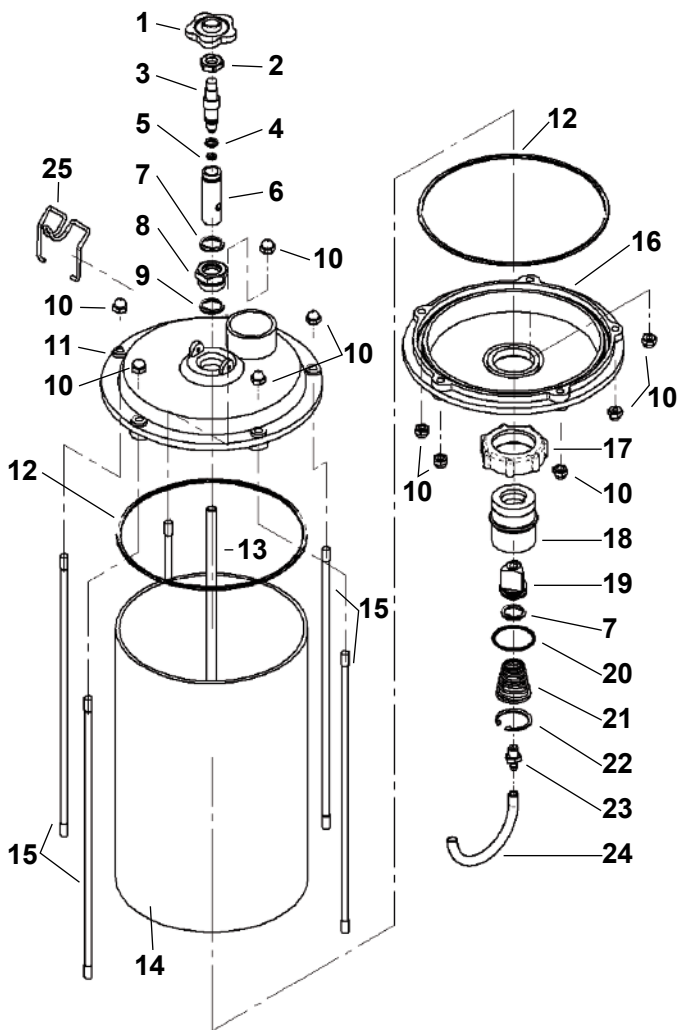

Exploded Parts Items:

Assy P/N S3341	Complete transparent bowl assembly
Assy P/N S3342	Upper cap assy (items#1 – 11)
Assy P/N S3343	Lower cap assy (items #16 – 24, 7, 10)
Assy P/N S3340	Transparent bowl kit (items #12 & 14)
Assy P/N S3357	Rod, connecting, set, 5 rods, 10 nuts
Assy P/N S3369	Seal kit, 8 pcs.

Item numbers shown below are for assembly/disassembly information only. Parts available in kits above.

1	Handle, valve
2	Washer, set
3	Stem, valve
4	Seal, valve stem
5	'O' Ring, valve stem
6	Guide, valve stem
7	'O' Ring, valve stem guide
8	Nut, retaining
9	Seal, retaining nut
10	Nut, cap
11	Cap, top, transparent bowl
12	Seal, transparent bowl
13	Rod, connecting, transparent bowl
14	Bowl, transparent
15	Bolt, connecting, transparent bowl
16	Cap, bottom, transparent bowl
17	Ring, retaining
18	Valve, plunger
19	Fitting, valve, plunger body
20	'O' Ring, plunger body
21	Spring, plunger body
22	Clip, retaining, plunger body
23	Fitting, breather

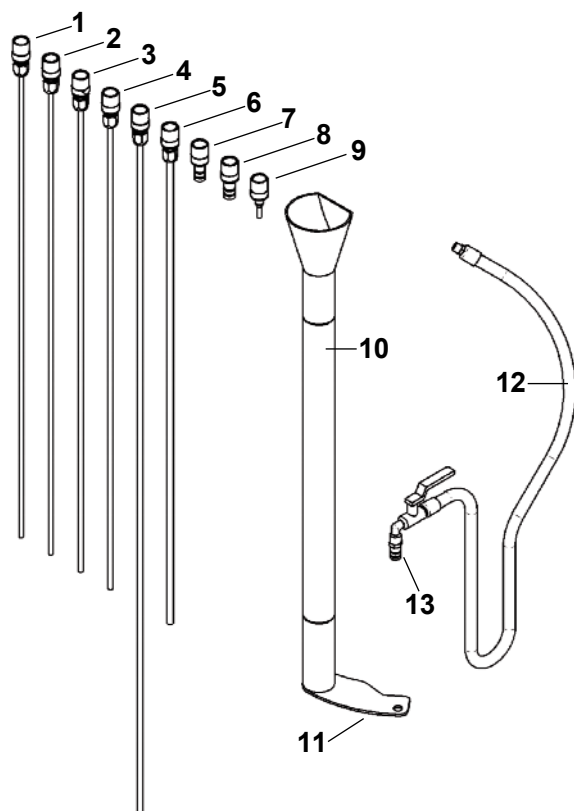

Parts applicable to all extractors

Exploded Parts Items:

1	P/N 24304	Flex probe, 0.20" x 27.7"
2	P/N 24305	Metal probe, 0.20" x 27.5"
3	P/N 24306	Metal probe, 0.24" x 27.5"
4	P/N 24307	Flex probe, 0.28" x 39.4"
5	P/N 24308	Flex probe, 0.32" x 27.5"
6	P/N 24316	Flex probe, 0.24" x 27.5"
7	P/N 24303	Connector for Citroene
8	P/N 24302	Connector for BMW
9	P/N 24300	Connector for VW
10	P/N 24299	Probe container
11	P/N S3332	Retainer, probe holder
12	P/N S3331	Suction hose assembly
13	P/N S3344	'O' Ring, suction probe fitting, (2 ea.)

**Parts applicable for
Models 24272 and 24273 only**

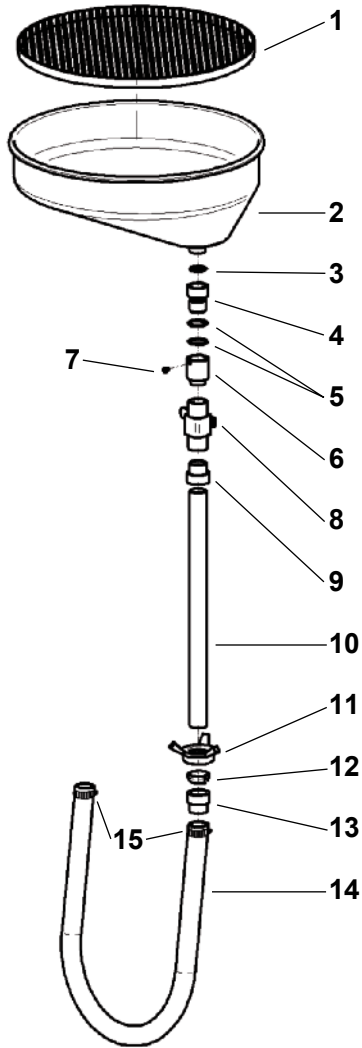

Exploded Parts Items:

Assy P/N S3200	Seal kit (incl. items 3, 5 & 12)
Assy P/N S3220	Drain tube Assy. (incl. items 3 - 13)
1	P/N S3207 Grate, filter
2	P/N S3206 Pan, drain, oil
3	P/N S3201 Seal, pan, oil drain
4	P/N S3215 Fitting, swivel, Assy.
5	P/N S3202 Seal, swivel retainer, (2 ea.)
6	P/N S3210 Fitting, swivel retainer
7	P/N S3213 Screw, retainer
8	P/N S3209 Tube, riser ball valve
9	P/N S3208 Fitting, top, riser tube
10	P/N S3221 Tube, riser
11	P/N S3216 Nut, wing, compression
12	P/N S3218 Fitting, compression
13	P/N S3261 Fitting, hose adapter, riser tube
14	P/N S3262 Hose, drain, riser tube
15	P/N S3263 Clamp, Hose