

Model No. 844 WHEEL BEARING PACKER

FOR BEARINGS WITH 1" TO 9-1/2" O.D. X 9/16" I.D. MIN.
FOR 120 LB. UNIVERSAL DRUM

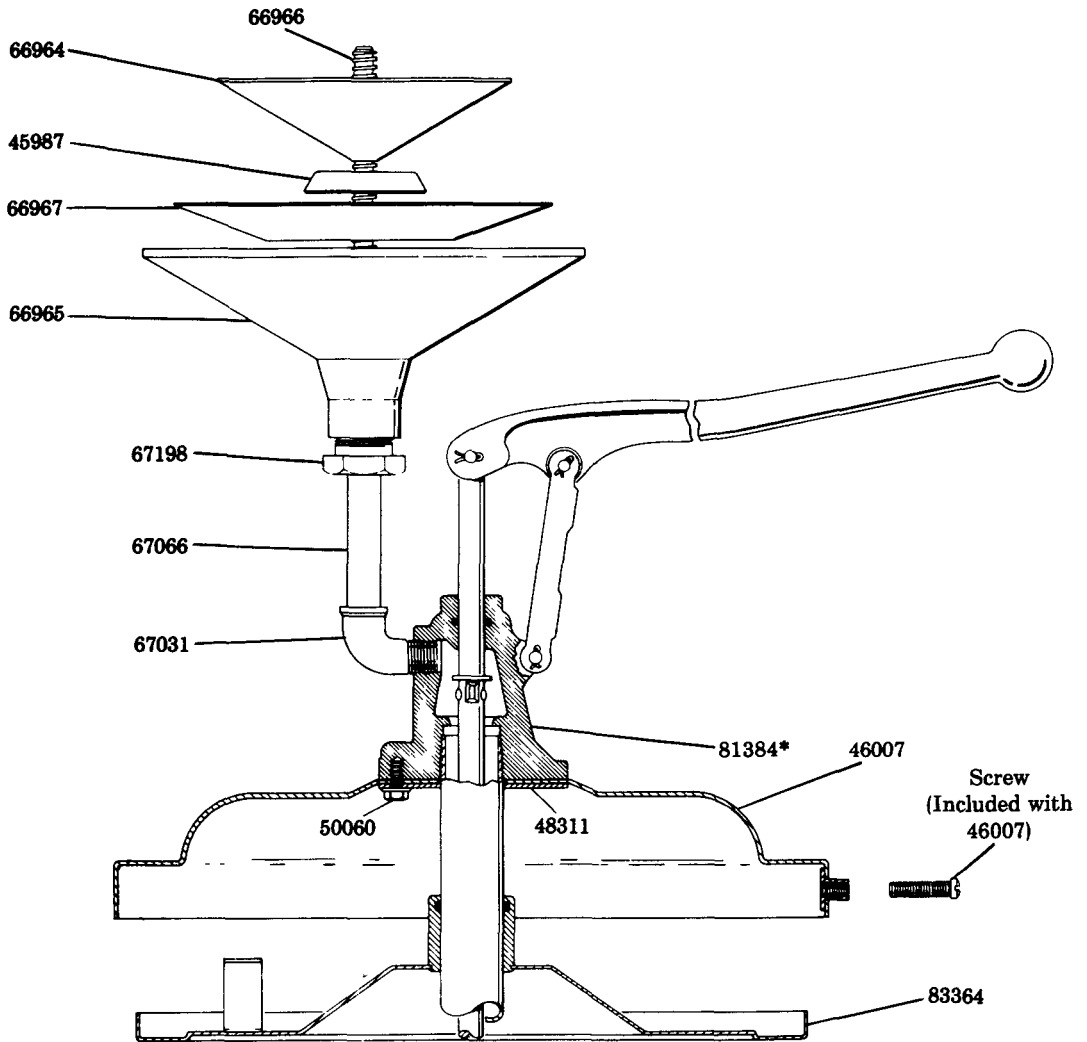

*** REFER TO SEPARATE INSTRUCTIONS**

81384 Basic Pump

NOTE:

To install 83364 Follower, it is necessary to remove 61024 Adapter Tube.

DESCRIPTION

The Model 844 Wheel Bearing Packer is designed to handle bearings with a minimum inside diameter of 9/16 inch to a maximum outside diameter of 9-1/2 inches.

INSTRUCTIONS

Remove 66964 Top Nut and 66967 Adapter. Position bearing on 66965 Bowl so the outer race of bearing will seal on bowl. Reassemble 66964 Top Nut and turn down tightly to assure seal on inner race of bearing. Operate pump slowly until grease extrudes around balls or rollers.

NOTES:

- 1) When lubricating bearings with an inside diameter of over 5-1/2 inches, it will be necessary to use the 66967 Adapter to assure seal on inner race.
- 2) When lubricating bearings with an outside diameter of 1 inch to 1-3/4 inches, it will be necessary to use the 45987 Adapter.

SERVICE PARTS

Part	Qty.	Description	Part	Qty.	Description
45987	1	Adapter	66967	1	Adapter
46007	1	Drum cover	67031	1	Street elbow
48311	1	Washer	67066	1	Nipple
50060	3	Screw	67198	1	Bushing
66964	1	Top nut	81384	1	Pump assembly
66965	1	Bowl	83364	1	Follower assembly
66966	1	Stud			