



INSTALLATION INSTRUCTIONS

Legato Performance Exhaust Kit #LEX4103

For 2015 Ford Mustang GT 5.0L V8

409 Stainless Steel w/304 Stainless Steel Tips

Removal of Stock System:

1. If a hoist or rack is available, raise the vehicle to a comfortable working height. If no lift is available you can jack up the vehicle and support it with jackstands. Make sure that the vehicle is safely positioned on the jackstands before getting under it.
2. Spray a penetrating lubricant onto the rubber hangers just behind the rear end housing and also at the rear of the vehicle.
3. To start, measure back 2-1/2" from the beginning of the straight area (see Figure 1) and mark as shown on both pipes. Support the exhaust system both in front and behind the area to be cut. Once you are confident of your measurements, cut both pipes at the marks. **Note: Use extreme caution in cutting due to the close proximity of the gas tank.**
4. Using a 13mm wrench, unbolt the two hangers

they are removed, place them next to the factory muffler of the corresponding side.

Installation of the Legato Exhaust System:

1. Place the Legato muffler units adjacent to the factory units and swap the front and rear hanger mounts from the stock mufflers to the Legato assemblies. Also place one of the supplied 2-1/2" clamp onto the inlet pipe of each assembly. Tighten the clamp just enough to hold in place.
2. Place the right muffler assembly (#4103-2) up in position and slide the inlet completely onto the factory pipe. Support the assembly with a stand and remount the rear hanger mount to the frame and tighten securely. Remount the front hanger to the cross member and tighten securely. Leave the inlet clamp loose for now. Repeat this step with the left muffler assembly (#4103-1) on the left side of the

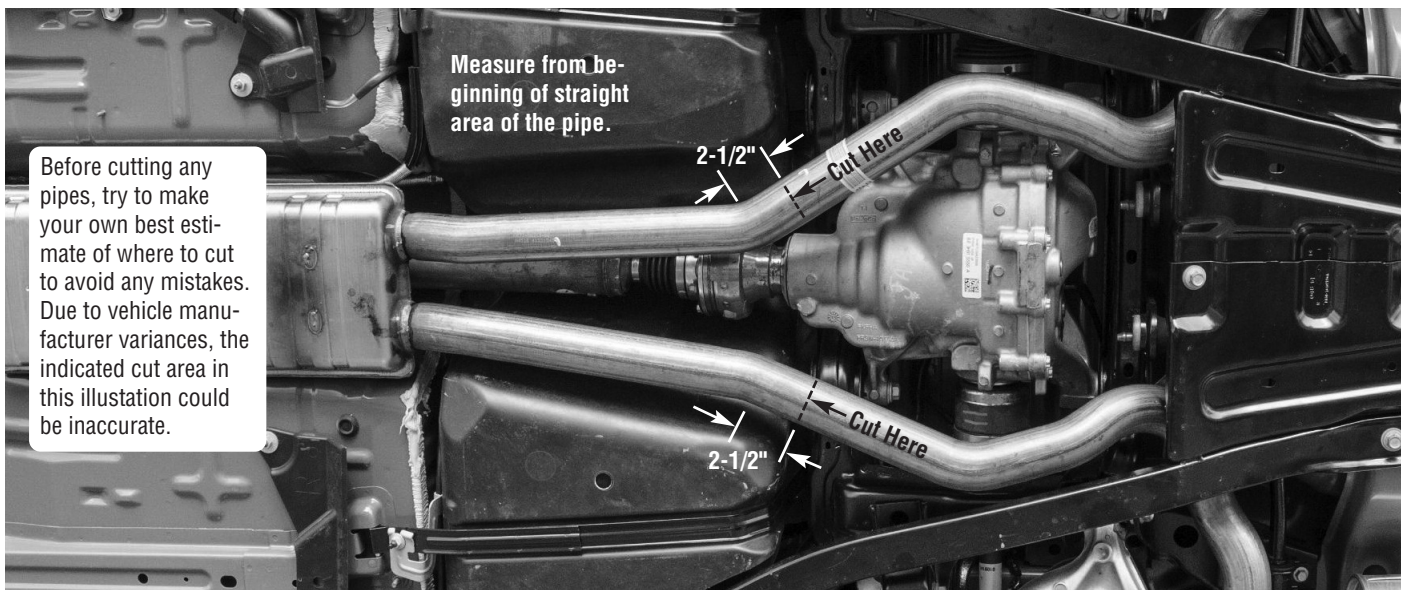

- from the crossmember that is located just behind the rear differential. Carefully lower the stand supporting the muffler and slide the muffler assembly forward to and out of the rear hanger mount. Repeat for the other side. Lower the assemblies to the floor leaving the front hangers attached.
5. Using a file or a die grinder, carefully deburr the end of the pipes where you made your cut.
 6. Using a 13mm wrench, remove the two hanger mounts at the rear of the vehicle from the frame. As

vehicle.

3. Adjust and level the two mufflers to provide a satisfactory fit. Check that the tips are positioned correctly. Once everything is positioned correctly you can tighten down the two clamps. Make sure that a minimum of 1/2" clearance is maintained around all parts of the system taking into consideration suspension travel and vibration.
4. For a totally secure installation we recommend a 1" weld on either side of the slip fit connections.

Legato Performance Exhaust Kit #LEX4103 For 2015-'16 Ford Mustang GT 5.0L V8

4000-3



4000-3



KIT CONTENTS		
Qty	Description	Pt. No.
1	Muffler (Left)	4103-1
1	Muffler (Right)	4103-2
Parts Kit		
2	2-1/2" Clamps	4000-3

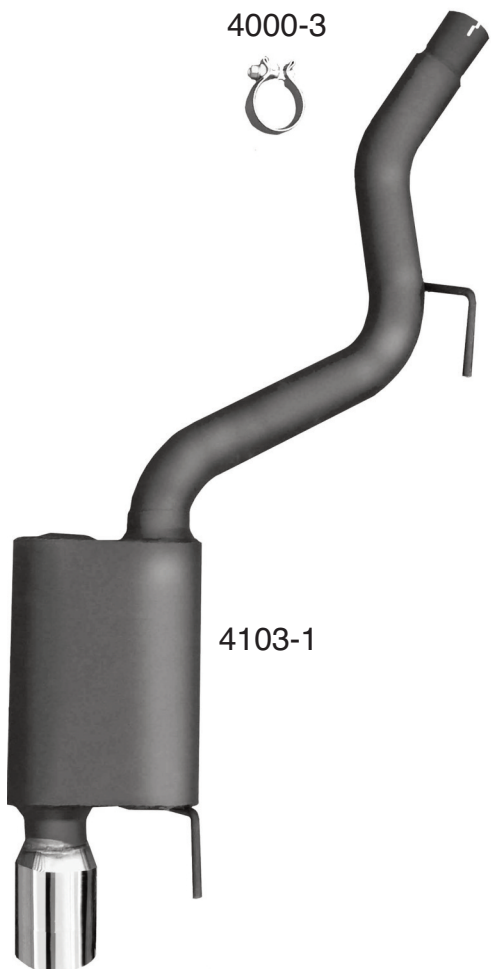

4103-1

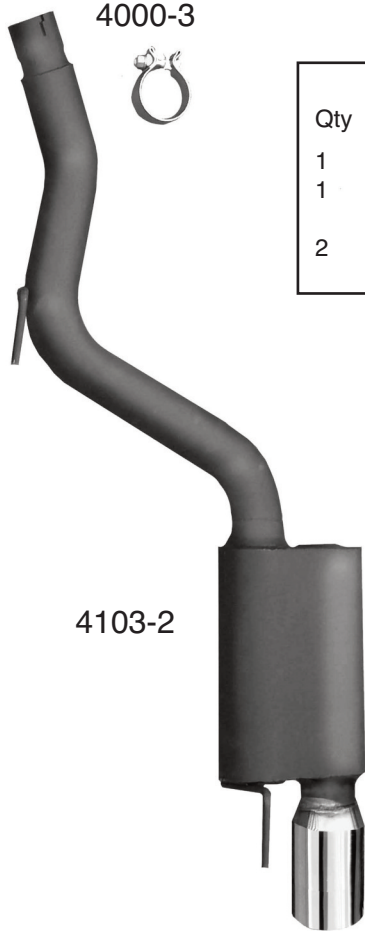

4103-2

**100%
Stainless
Steel**