



INSTALLATION INSTRUCTIONS

**Legato Performance Exhaust Kit #LEX4221
For 2009-'14 Dodge Challenger R/T 5.7L V8
409 Stainless Steel w/304 Stainless Steel Tips**

Legato Performance are proud to offer a high quality product at the industries most competitive pricing!

Removal of Stock System:

1. If a hoist or rack is available, raise the vehicle to a comfortable working height. If no lift is available you can jack up the vehicle and support it with jackstands. Make sure that the vehicle is safely positioned on the jackstands before getting under it.
2. Apply a lubricant to the rubber hanger rods/mounts that support the mufflers. This will ease the removal and installation.
3. At the rear of each tailpipe there is a clamp that secures the factory stainless steel tip to the tailpipe. Loosen the clamp and remove the factory tip. After the tip is removed also remove the clamp from the tailpipe. The clamp is tack welded in one spot and must be wiggled loose until the weld breaks. The tips and clamps will be reused when installing the Legato system.
4. Loosen the clamps where the left tailpipe attaches to the mufflers. Slide the hanger rods out of the rubber mounts on the vehicle and remove the left tailpipe.
5. Support the right side muffler with a stand and loosen the clamps at the slip fit connection to the catalytic converters. Remove the three remaining hanger rods from the rubber mounts and slide the entire remaining system back off the headpipes.

Installation of the Legato System:

1. Before installing anything, prep the clamps supplied with the Legato system by removing the nuts and applying a thick lubricant such as white grease or anti-seize compound to the threads.
2. Place supplied clamps at the front end of the scavenger pipe

- assembly (#4221-3). Then slide the scavenger pipe onto the head pipes. Level and center the scavenger pipe assembly in the drive line tunnel and support with a stand. Tighten the two clamps enough to hold but still allow for adjustment.
3. Place a supplied clamp onto the inlet of each muffler. Then slide the mufflers onto the scavenger pipe one at a time, and support them with stands. Level the mufflers and tighten the clamps enough to hold but still allow some adjustment.
4. Place a supplied clamp onto the left muffler outlet. Place the left tailpipe into position and starting from the rear, connect the hangers on the tailpipe to the rubber mounts on the vehicle. Then slide the tailpipe onto the muffler outlet. Adjust the tailpipe so the hangers are level and tighten the clamp enough to hold but still allow for some adjustment. Repeat this step for the right tailpipe.
5. Adjust the position of all the pipes and the mufflers to provide a satisfactory fit. A minimum of 1/2-inch of clearance around all parts of the system must be maintained while considering suspension travel and vibration in mind. After you are satisfied with the positioning of all the parts the clamps can be securely tightened throughout the entire system.
6. Re-attach the factory stainless tips to the rear of each tailpipe using the factory clamps previously removed. Adjust the position of the tips to the desired location and tighten the clamps.
7. After the system is secure, slide the #4000-6 hanger keepers onto the ends of each hanger rod to prevent the rods from slipping out of the rubber mounts.

**100%
Stainless
Steel**

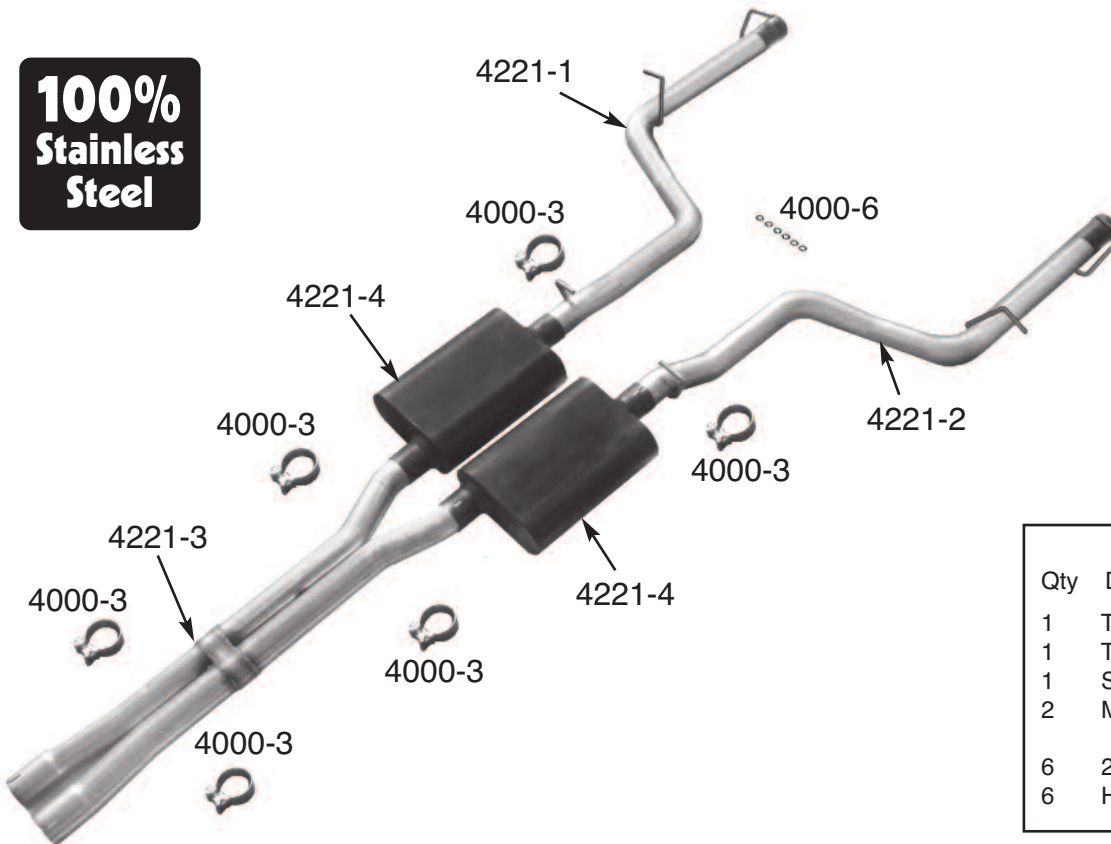

KIT CONTENTS		
Qty	Description	Pt. No.
1	Tailpipe (Right)	4221-1
1	Tailpipe (Left)	4221-2
1	Scavenger Assy	4221-3
2	Muffler	4221-4
Parts Kit		
6	2-1/2" Clamps	4000-3
6	Hanger Keepers	4000-6

Legato Performance Exhaust Kit #LEX4221 for 2008-'14 Dodge Challenger

Learn more about performance exhaust systems we have.