



LAKEWOOD "TRACTION . . . ACTION" LIFT BARS INSTALLATION INSTRUCTIONS

Part #21900

Fits 1979-98 Ford Mustang

Features:

- Legal for NHRA Stock Eliminator Classes
- Completely bolt-on. No welding required
- Corrects mis-aligned differential pinion angle
- Does not change stock wheel base location
- Polyurethane bushings maintain proper rear end alignment
- Improved ride and greatly reduced road noise compared to other brands

WORK SAFELY!

Installation of these traction bars requires working underneath vehicle.

USE EXTREME CARE AND CAUTION WHEN WORKING UNDERNEATH VEHICLE.

Never get near or under vehicle until you are confident that it is safely supported and will not move or fall from its raised position.

DO NOT USE A BUMPER JACK.

PREPARATION FOR INSTALLATION

1. Place vehicle on a solid level surface to ensure safe installation.
2. Place wheel blocks in front of and behind both front wheels to prevent movement in either direction.
3. Raise rear of vehicle and support flat area of chassis in front of lower control arm attaching point using approved automotive support stands having adequate load capacity. **DO NOT** put support stands under the axle housing.

Note: Raise vehicle high enough (approximately 15") to allow adequate clearance for coil spring removal.

TRACTION BAR ASSEMBLY

1. Install grease fittings (supplied) into each end of traction bar by driving fittings into drilled hole of bushing eyelet using a hammer and either a 9/32" or 7mm socket. Use care not to damage fittings.
2. Apply lubricant (supplied) to polyurethane bushings and steel sleeves, then install into eyelet ends. **(See illustration #1).**

TRACTION BAR INSTALLATION

CAUTION:

DO NOT BEGIN THIS INSTALLATION UNTIL YOU ARE CONFIDENT THAT VEHICLE IS SECURE AND SAFELY SUPPORTED.

Note:

There is a right hand and left hand traction bar. The correct bar for each side can be determined by the location of the stabilizer bar mounting plate and coil spring perch. The bars should be installed with the stabilizer mounting plate located toward the outside and the spring perch toward the rear.

1. Remove both rear wheels.
2. Apply penetrating oil or rust release lubricant to front and rear mounting bolts of lower control arms, stabilizer bar mounting bolts and horizontal quad shock absorber mounting bolts/nuts.
3. Remove stabilizer bar and disconnect horizontal quad shocks from axle housing brackets.
Note: Horizontal quad shocks will not be re-used.
4. Disconnect exhaust system as necessary and drop down far enough to allow access to front lower control arm bolts.
5. Raise axle housing up approximately 2" (a hydraulic floor jack is recommended for this procedure).

ILLUSTRATION #1

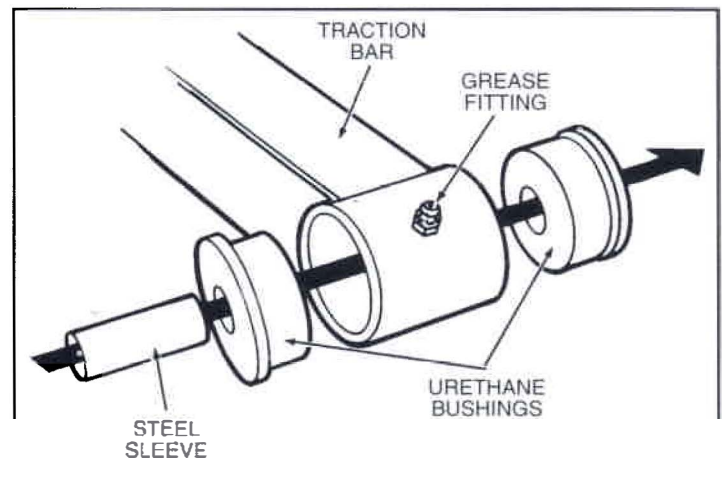

- Using an 18mm hex wrench, remove nuts from vertical shock absorber lower bracket mount studs. Compress shocks slightly to facilitate removal of bracket studs from axle housing brackets.

Caution:

Shock absorbers are pressurized with gas, use care when removing. Carefully release shocks allowing them to extend all the way out.

- Lower the axle housing and remove coil springs.
- Using an 18mm hex socket and wrench, remove lower control arms. **DO NOT** discard the front bolts and nuts, they will be re-used.
- Raise axle housing up. Align inner and outer traction bar mounting brackets to the sides of existing factory control arm brackets located on the axle housing.

Note:

There are right-hand and left-hand inner/outer brackets. Refer to photo #1 for identification.

Place the supplied spacer tube inside the factory bracket and install the new metric 12mm x 1.75 x 120mm hex head bolt (supplied) through the new mounting brackets, factory brackets and spacer tube. **(See photo #2).** Thread on the new metric 12mm x 1.75 hex nut (supplied) and tighten just snug (**Note:** be sure that shock absorber bracket stud mounting holes are aligned).

PHOTO #1

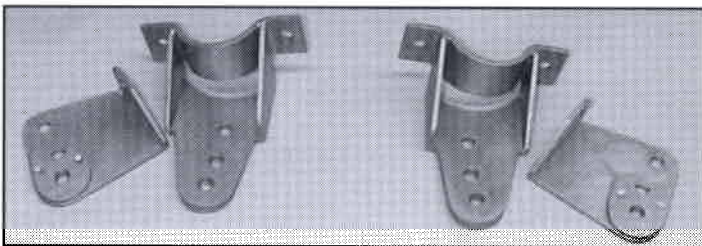

Right Hand Side

Left Hand Side

PHOTO #2

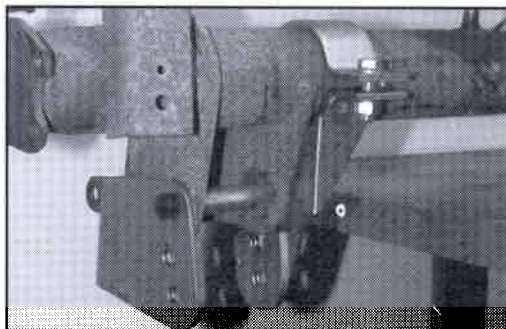

Right Hand Passenger Side Shown – Front View

- Place upper housing bracket clamp **under** brake line (if necessary, carefully and gently bend brake line away from housing to allow clamp to fit). Align the clamp bolt holes with the lower bracket and install the 7/16-20 x 1-3/4" hex head bolts (supplied). Thread on the 7/16-20 self-locking hex nuts and tighten only snug. Use the supplied flat washers between the bolt head, hex nut and bracket clamp surfaces. **(See photo #3).**

PHOTO #3

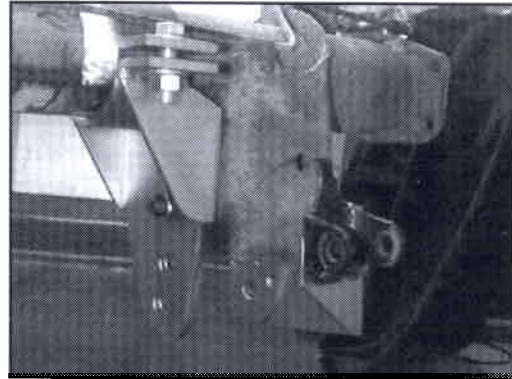

Right Hand Passenger Side Shown – Rear View

- Determine the correct traction bar for the side you are working on (the bars should be installed with the stabilizer mounting plate located toward the outside and the spring perch toward the rear). Install the front end of the bars to the chassis using the stock factory mounting bolts and nuts previously removed. **DO NOT TIGHTEN.** Swing the rear of the bars up until the bushing mount hole is aligned with the lowest hole in the new mounting brackets (if necessary, rotate axle housing by raising upward with floor jack positioned under pinion center section casting until holes are aligned). Install the 1/2-20 x 4-1/2" hex bolts (supplied) and thread on the 1/2-20 self-locking hex nuts. **(See photo #4).** Tighten only snug.

PHOTO #4

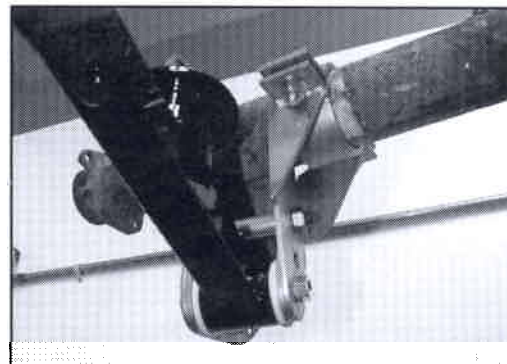

Right Hand Passenger Side Shown

12. Lower the axle housing and place coil springs into position. Be sure to replace the factory rubber seats on the top and bottom of the springs.
13. Raise axle housing up to compress coil springs enough to allow re-attachment of the vertical shock absorbers. Re-attach shock absorber lower bracket mount to axel housing brackets and replace factory hex nuts onto mounting studs. Tighten securely.
14. Securely tighten all traction bar mounting bracket hardware at this time. Tighten front and rear traction bar mounting bolts to 80 ft./lb. torque.
15. When both traction bars are installed, re-attach the stabilizer bar using the stock factory mounting bolts and nuts.
Note: The stabilizer bar is not recommended for drag racing. It is used to control body roll under road handling conditions. The factory horizontal quad shocks are also not necessary as the Lakewood Traction Bars will now control wheel hop.

16. Lubricate both ends of the traction bars with a good quality chassis grease.
17. Re-attach exhaust system and tighten all fasteners securely.
18. Install wheels and properly tighten lug nuts to wheel manufacturers specifications.
19. Carefully remove support stands and lower vehicle to ground.

This completes the installation. You can now test drive the vehicle and will notice a big improvement in traction control.

Important: Periodically check to make sure that all mounting hardware is securely tightened. Use a good quality chassis grease to keep bushings and sleeves properly lubricated.

Recommended chassis modifications:

For serious drag racing, we recommend reinforcing the upper and lower control arm chassis mounts. They are only spot welded in place from the factory but should be fully welded to the floor pan for added strength.

Tuning Tips:

These traction bars can be attached to the axle housing brackets in 1 of 2 positions. The lower holes will cause the rear tires to "plant" harder than the upper holes. If you have too much traction, move the rear attachment to the upper holes of the axle housing brackets.

Illustration #2 shows what happens to the instant center (imaginary intersection point between the upper and lower control arms) when the lower control arms are attached to each of the two optional mounting holes in the axle housing brackets.

When the differential pinion gear is turned by the drive shaft, which is driven by the engine, the pinion gear turns the ring gear causing the axle housing to rotate, pulling back on the upper control arms and pushing forward on the lower control arms. These forces theoretically meet at the instant center point (as shown on the illustration). The shorter the instant center point is, the more the tires will separate from the body upon launch.

Recommended optional Lakewood products:

- For drag racing, the factory gas shocks should be replaced with a 50/50 ratio rear shock absorber **#40301**
- Front Drag Struts are also available for 1979-93 model years in ratios of 70/30 **#40501** or 90/10 **#40511**
- Heavy-duty upper control arms with poly-urethane bushings reduce flex and provide stability **#20152**
- Bolt-on Subframe Connectors, for 1979-93 model years, will help eliminate body flex and greatly strengthen the chassis **#20485**
- Bolt-in Drive Shaft Safety Loop for 1979-93 model years **#18015**

See your local retailer of Lakewood products for specific prices.

ILLUSTRATION #2

