



## H.D. REAR UPPER CONTROL ARMS INSTALLATION INSTRUCTIONS

Part #20152 *Fits 1979-2003 Ford Mustang*

### Features:

- Heavy gauge steel eliminates flex for increased traction
- Completely bolt-on, no welding required
- Polyurethane bushings for positive suspension control and stability
- Legal for NHRA Stock Eliminator Classes

### IMPORTANT!

*Read this instruction sheet completely so that you thoroughly understand it and are familiar with the procedure before attempting installation.*

### WORK SAFELY!

*Installation of these control arms requires working underneath vehicle.*

***USE EXTREME CARE AND CAUTION WHEN WORKING UNDERNEATH VEHICLE.***

*Never get near or under vehicle until you are confident that it is safely supported and will not move or fall from its raised position.*

***DO NOT USE A BUMPER JACK.***

### PREPARATION FOR INSTALLATION

1. Place vehicle on a solid level surface to ensure safe installation
2. Place wheel blocks in front of and behind both front wheels to prevent movement in either direction.
3. Raise rear of vehicle and support flat area of chassis in front of lower control arm attaching point using approved automotive support stands having adequate load capacity. **DO NOT** put support stands under the axle housing. **Note:** Raise vehicle high enough to allow adequate clearance for coil spring removal.

### CAUTION

***DO NOT BEGIN THIS INSTALLATION UNTIL YOU ARE CONFIDENT THAT VEHICLE IS SECURE AND SAFELY SUPPORTED!***

### CONTROL ARM ASSEMBLY

1. Install grease fittings (supplied) into each end of control arm by driving fittings into drilled hole of bushing eyelet using a hammer and either a 9/32" or 7mm socket. Use care not to damage fittings (*see illustration*).

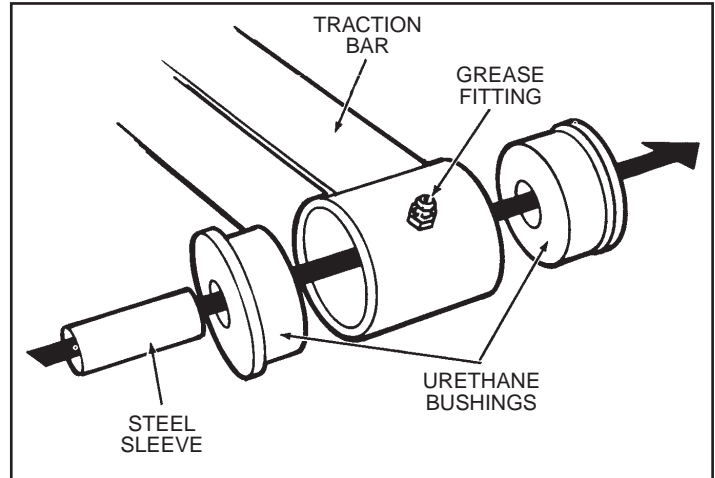

2. Apply lubricant (supplied) to polyurethane bushings and steel sleeves, then install into eyelet ends as shown.

### CONTROL ARM INSTALLATION

### NOTE

*We recommend working on only one side at a time.*

1. Remove both rear wheels.
2. Apply penetrating oil or rust release lubricant to front and rear mounting bolts of upper control arms.
3. Raise axle housing up approximately 2" (a hydraulic floor jack is recommended for this procedure).
4. Using an 18mm hex socket and wrench, remove upper control arm. **DO NOT** discard the bolts and nuts, they will be reused.
5. Install the control arm to chassis and axle housing brackets using the stock factory mounting bolts and nuts previously removed.

**Note:** Clean and lubricate axle and chassis control arm mounting brackets with a good quality chassis grease to ease installation.

6. Tighten front and rear control arm mounting bolts to 80 ft./lb. torque.

7. Follow the same above procedure for installation of Lakewood Control Arm on other side of vehicle.
8. Lubricate control arm bushings with a good quality chassis grease.
9. Install wheels and properly tighten lug nuts to wheel manufacturers specifications.
10. Carefully remove support stands and lower vehicle to ground.

***THIS COMPLETES THE INSTALLATION.  
YOU CAN NOW TEST DRIVE THE VEHICLE.***

***Recommended optional Lakewood products:***

- For drag racing, use Lakewood Traction... Action Lift Bars for 1979-98 Mustangs **#21900**, for 1999-03 Mustangs **#21901**
- For drag racing, the factory rear shocks should be replaced with a 50/50 ratio shock absorber (1979-1993 Mustangs) **#40301**
- Front Drag Struts are also available for 1979-93 model years in ratios of 70/30 **#40501**, or 90/10 **#40511**. Also 1994-2003 Mustangs 70/30 **#40506**, and 90/10 **#40516**
- Rear Lower Control Arms with polyurethane bushings to reduce flex and provide stability for 1779-98 Mustangs **#20150**, and 1999-03 Mustangs **#20151**
- Bolt-on Subframe Connectors for 1979-93 Mustang will help eliminate body flex and greatly strengthen the chassis **#20485**
- Replacement Bushing Set. Bushings for all Mustang Lakewood Control Arms and Traction Bars **#20538**
- Bolt-in Drive Shaft Safety Loop for 1979-03 Mustangs **#18017**