

PART APPROVAL



Parts Approval

Nr. / No. 1228/18
vom / of 17.10.2018



**on the compliance of a vehicle when vehicle parts are properly installed
and fitted to the car in accordance with § 19 Par. 3 No. 4 StVZO**

Modification

fbaus / Continuously adjustable suspension system for
lowering the car body

Part type(s)

: 3A7 20 0BH

Manufacturer

: KW automotive GmbH
Aspachweg 14
D-74427 Fichtenberg

Vehicle Manufacturer / Type(s)

: BMW M / M3

max. axle load

: VA (front axle) 970 kg
: HA (rear axle) 1080 kg

0. Instructions for vehicle own

Performance and confirmation without delay of modification acceptance

With the modification the type approval of the vehicle will expire if the modification acceptance provided for in StVZO § 19 Par. 3 is not performed and confirmed without delay or if conditions laid down are not complied with.

After performance of the technical modification, the vehicle must be pre-sented without delay together with the present TÜV parts approval to an officially recognised inspector at a Technical Inspection Centre or to an inspection engineer from an officially recognised inspection organisation to perform and confirm the specified modification acceptance.

Parts Approval

Nr. / No. 1228/18
vom / of 17.10.2018



Compliance with Conditions and Notes

The Conditions and Notes given in III. and IV. must be complied with.

Availability of documents

After the acceptance procedure the certificate with confirmation of the modification acceptance must be carried in the car and presented to authorised persons on demand; this will not apply once the vehicle documents have been amended.

Amendment of vehicle documents

The vehicle owner must apply, in accordance with the provision in the confirmation of modification acceptance, for the competent licensing authority to amend the veh. documents (vehicle registr. Further conditions can be found in the confirmation of modification acceptance.

I. Field of application

Vehicle manufacturer	Trade name	Vehicle type	Variants and versions	T Type approval
BMW M	M2, M2 Competition	M3	alle / all	e1*?/?*0377*..

The part of the EC type approval number showing *?/?* merely document the current status of the framework directive and are of no significance for this parts approval as long as the parts of the vehicle which are relevant to the lowering of the bodywork have not changed.

Parts Approval

Nr. / No. 1228/18
vom / of 17.10.2018



II. Description of the modification

Front axle

	V Pre spring	Main spring
Marking	non existent	imprinted
Corrosion protection		EPS-powder coating
Wire size Outer diameter	oben / top mitte / middle unten / bottom	10,4 mm - mm
Untensioned height		82 mm - mm
Number of coils		200 mm 7
Coil shape		Cylinder, head(s) baselined
Spring characteristic		linear

	Spring cup seat (top))Spring cup seat (bottom)
Max. diameter	80 mm	82 mm
Diameter rest	61 mm	61 mm
Height	14 mm	24 mm
Spring height adjustment	Infinitely adjustable cup seat (Strut)	

	Strut
Damping adjustment (rebound/ compression)	without / manual
Marking	202 1040 L/R

	Top mount at the strut
Specification	Camber adjustment by changing the position of the upper strut bearing unit on the top mount plate
Article No.	links / left 190 00 919 rechts / right 190 00 920

	Rubber or polyurethane foam element
Bump Stop	50/50 mm
High/Diameter	extended by 30 mm
Bump travel	

Parts Approval

Nr. / No. 1228/18
vom / of 17.10.2018



	Pre spring	Main spring
Marking	<i>imprinted</i>	<i>imprinted</i>
Corrosion protection	<i>EPS-powder coating</i>	<i>EPS-powder coating</i>
Wire size	5,4 x 9,4 mm	13,3 mm
Outer diameter	- mm	- mm
oben / top	80 mm	88 mm
mitte / middle	- mm	- mm
unten / bottom	80 mm	200 mm
Untensioned height	80 mm	200 mm
Number of coils	6	7,3
Coil shape	<i>Cylinder, head(s) baselined</i>	<i>Cylinder, head(s) baselined</i>
Spring characteristic	linear	linear

	Spring cup seat (top)	intermediate ring (middle)
Max. diameter	80 mm	80 mm
Diameter rest	61 mm	61 mm
Height	17 mm	20 mm

	Spring cup seat (bottom)	
Max. diameter	95 mm	
Diameter rest	61 mm	
Height	32 mm	
Spring height adjustment	<i>Infinitely adjustable cup seat (Bushing)</i>	

	Shock absorber
Damping adjustment (rebound/ compression)	<i>without / manual</i>
Marking	202 1141 L/R

	Rubber or polyurethane foam element
Bump Stop	
High/Diameter	35/50 mm
Bump travel	<i>extended by 15 mm</i>

Parts Approval

Nr. / No. 1228/18
vom / of 17.10.2018



III.

Notes on possible combination with other modifications

III. 1 Wheel/tyre combinations

There are no technical objections against the use of all O. E. wheel/tyre combinations.

If other wheel-/ tyre combinations are used, the examination in accordance with § 21 German Road Traffic Licensing Code - StVZO must be carried out by an officially recognised expert.

III. 2 Aerodynamic devices, special exhaust systems etc.

The dynamic ground clearance is decreased by the provision of special springs/dampers which increase the bump travel of the front and rear axle. In the case of the test vehicle, the min. ground clearance of 80 mm is complied with (below front axle). Care must be taken when driving over humps, barriers and heightened paving or road surfaces.

If special spoilers, aprons and exhaust systems are mounted, attention must be paid to the decreased overhang angle (driving up ramps etc.).

IV. Conditions and Notes

Conditions and notes for the installation shop and modification acceptance

Mounting of the vehicle bodywork components will be performed in accordance with the vehicle manufacturer's specifications which must be included in the delivery and should be carried out by a
Please check regularly, that the main and helper spring at rear axle are in right position and that there is enough pre-tension, when the rear axle is fully extended. In the case of sufficient pretension, the length of the helper spring must be by approx. 60 mm.

The headlight adjustment has to be checked.

After modification an axle alignment must be carried out on the vehicle.

The base setting at the top mount of the front struts is marked on the measurement- adjustment report with dashes on the top mount plates or rather marked visible on the op mount. On public roads the car may only be driven in this base setting.

The record of check and adjustment has to be provided for the modification acceptance.

The bump stops (rubber or polyurethane foam element) must correspond to the descriptions of this report. Additional travel limiters are not allowed.

Use of the lowering kit on vehicles with levelling system is not permitted.

The vehicle height must be laid down in the vehicle documents in box 20. The precise measure of the lowering will depend on the specific vehicle tolerances, tyre size and vehicle version.

dimensions (mm)

vehicle application	adjustment range (min. – max.)		Clearance		Size of lowering	
	VA/front ¹⁾	HA/rear ²⁾	VA/front ³⁾	HA/rear ³⁾	VA/front	HA/rear
BMW M2, M2 Competition	145 – 160	15 – 35	315	320	15 – 40	20 – 45

1) Distance from the spring rest to the nearest fastening screw

2) Distance from contact point of the car to the adjustable spring perch

3) Minimum distance from wheel centre to wheelhouse rim

Parts Approval

Nr. / No. 1228/18
vom / of 17.10.2018



Amendment of vehicle documents:

Amendment of the vehicle documents is only necessary the next time the approval authority has to do with the vehicle documents. The following example is suggested for the entry:

V. Basis of tests and test results

*The test vehicle and the modification parts were subjected to a test in accordance with the test conditions regarding raising / lowering of vehicles contained in VdTÜV Merkblatt 751 (08.2008).
The test conditions were fulfilled.*

VI. Annex: none

Parts Approval

**Nr. / No. 1228/18
vom / of 17.10.2018**



VII. Concluding certification

It is hereby certified that the vehicles described under field of application satisfy the regulations of StVZO in the current version after modification and performed and confirmed modification acceptance, provided the conditions/notes given in the present TÜV approval are observed.

The manufacturer KW automotive GmbH maintains a quality management system according to ISO 9001: 2015 (Certificate Registration No.: 12 100 22913 TMS).

The parts approval may only be reproduced and passed on by the manufacturer in its unabbreviated form.

The TÜV parts approval shall cease to be valid if technical modifications are made to the vehicle part or if modifications made to the vehicles described affect use of the part and in the case of any changes to the statutory specifications.

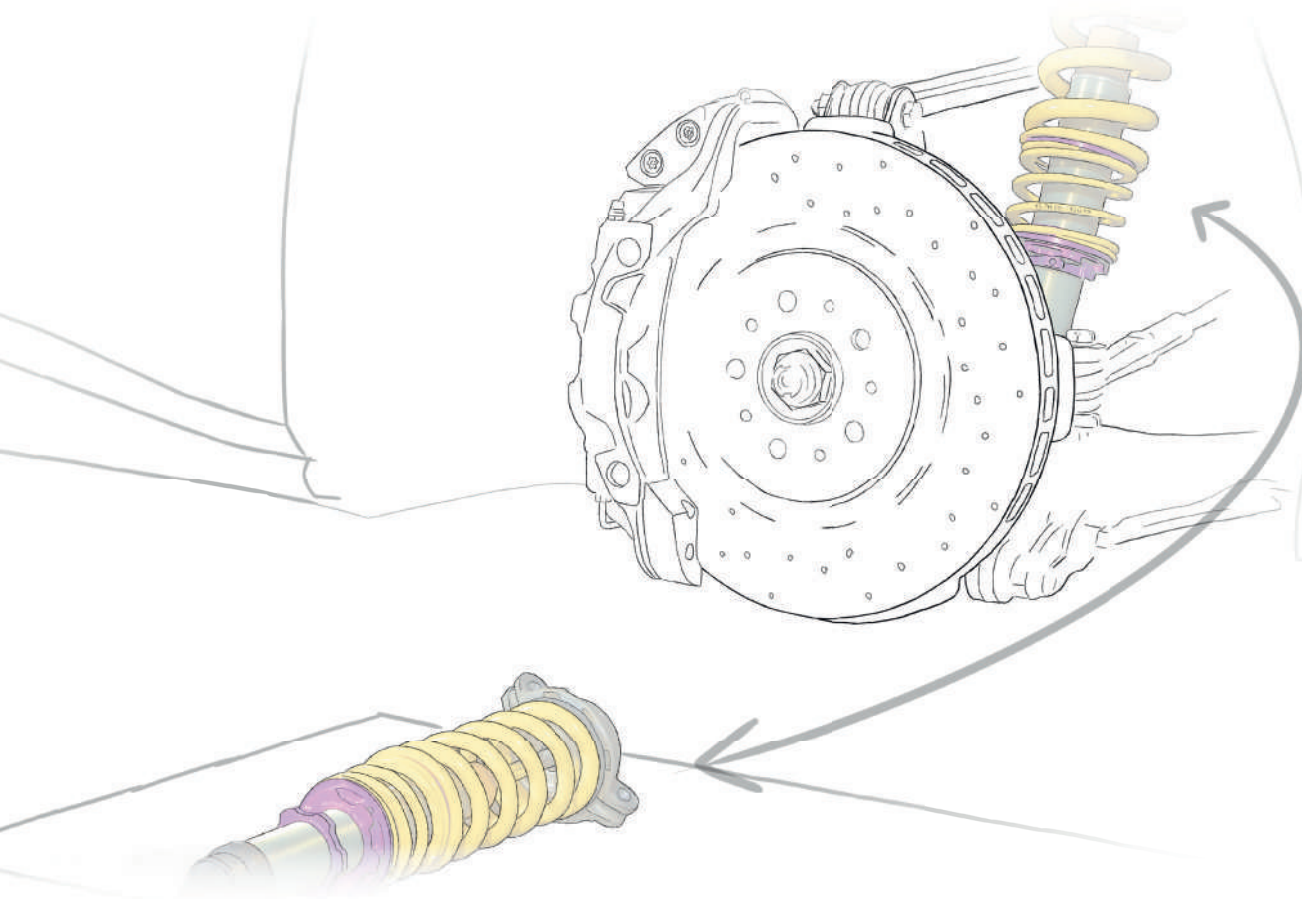

INSTALLATION INSTRUCTIONS





INSTALLATION INSTRUCTIONS

**Before you begin installation,
please read the following carefully:**

- **Ensure that certificate matches the vehicle specifications (front vehicle identification number (VIN)) etc...**
- **The suspension components must match the suspensions application specifications (springs and shock/struts identification numbers).**
- **The instructions have to be strictly observed.**

KW Coilovers for automobile suspensions are designed for easy installation. If not otherwise stipulated in these instructions, all suspension components are installed and removed in accordance with the manufacturer's specifications for installing and removing standard springs and damper components. At the time of printing all instructions and specifications are correct.

Technical data	Coilover part number 3A7 20 0BH			
Vehicle model	BMW M2, M2 Competition type M3		max. permissible front axle load: 970 kg	
	front axle		rear axle	
Spring signature	50-200*		20-60-80 / 120-200*	
Coilover strut / Shock absorber signature	202 1040		202 1141	
Approximate distance measurement A Front axle: Fastening screw - spring contact area Rear axle: Seating height adjustment - spring contact area or fastening screw - spring contact area	min:	max:	min:	max:
	145 mm / 5,7 inch	160 mm / 6,3 inch	15 mm / 0,6 inch	35 mm / 1,4 inch
Approximate measurement* B in mm / inch: wheel hub center to fender edge	min:		min:	
	315 mm / 12,4 inch		320 mm / 12,6 inch	

Calculating the adjustment range (distance measurement A) : (Photos are examples only)

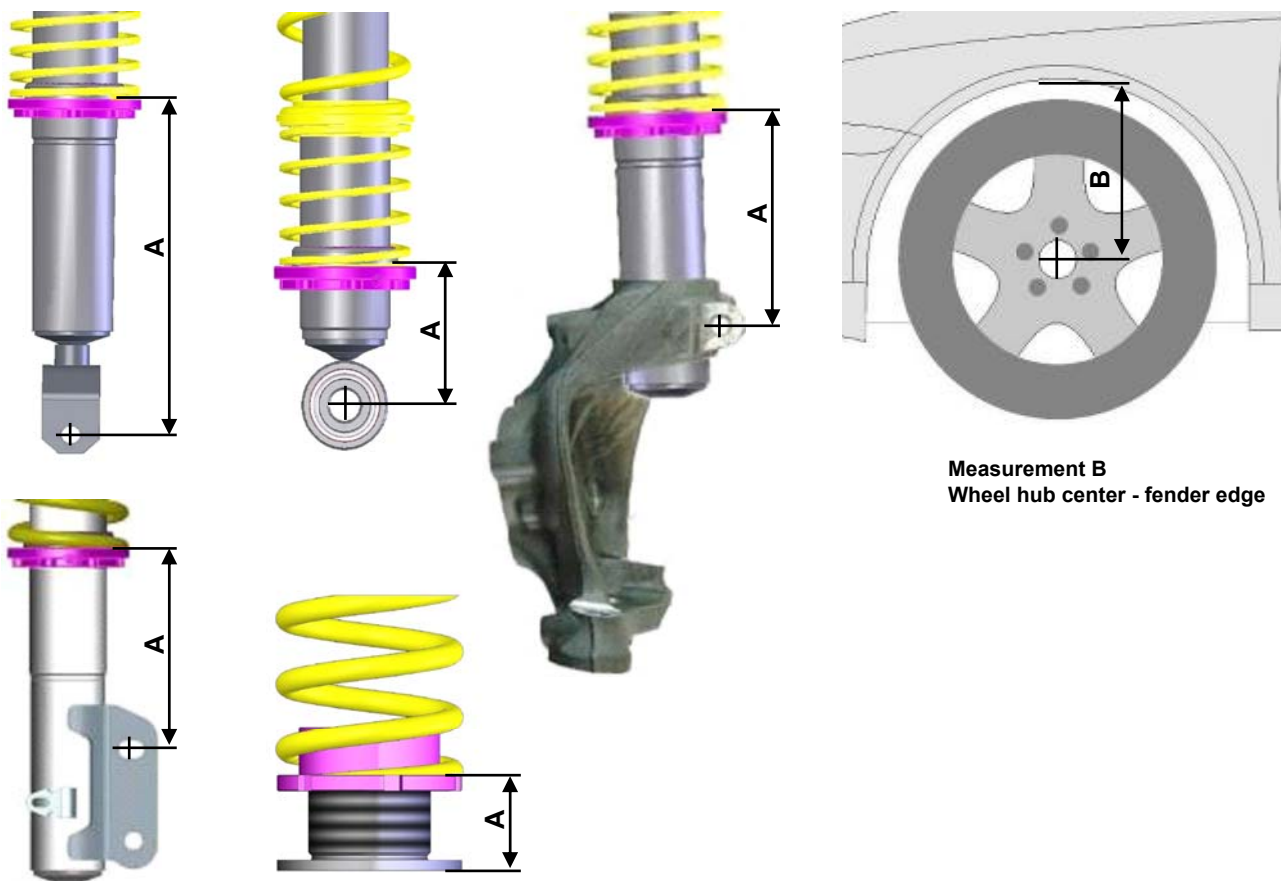

Measurement B
Wheel hub center - fender edge

Please enter the adjusted height of the modified car into the list:

Coilover part no	Vehicle type	Measurement A		Wheel hub center - fender edge Measurement B	
		Front	Rear	Front	Rear

* **IMPORTANT:** The allowable measurement between wheel hub center and fender edge as indicated above, may not exceed these measurements when using standard fenders.

Allgemeine Montagehinweise:

1. Wir empfehlen dringend, die Fahrwerksmontage nur auf geeigneten und geprüften Hebebühnen durchzuführen.
2. **Achtung!** Falls das Fahrzeug mit Höhensensoren ausgestattet ist (Niveauregulierung, Scheinwerferhöhenverstellung) sollten die Sensoren vor dem Ausbau der Federbeine bzw. Stoßdämpfer demontiert werden, da diese sonst beschädigt werden können.
3. Die Federbeine sind anhand der Fahrzeughersteller-Richtlinien zu demontieren.
4. Zum Zerlegen der Original-Federbeine sind die vom Fahrzeughersteller vorgeschriebenen Montagewerkzeuge bzw. geeignete Federspanner zu verwenden.
5. Die angelieferten Federbeine bzw. die Tieferlegungskomponenten sind, wie auf den nachfolgenden Seiten beschrieben, zu montieren.
6. Die Befestigungsmuttern der Kolbenstangen dürfen nur mit geeignetem Spezialwerkzeug angezogen werden. Es darf keinesfalls ein Schlagschrauber verwendet werden. Die Kolbenstange darf **niemals** mit einer Zange oder ähnlichem festgehalten werden. Eine Beschädigung der Kolbenstange ist auf jeden Fall zu vermeiden, denn schon die kleinste Oberflächenverletzung führt zum Defekt und Gewährleistungsausschluss.
7. Das Abstandsmaß an jedem Federbein so einstellen, dass es einem Mittelmaß der Werte der auf Seite 2 aufgeführten Tabelle entspricht.
Beispiel: Bei einem angegebenen Abstandsmaß von 20 - 60 mm sollten 40 mm eingestellt werden.
8. Der Verstellfederteller ist durch Anziehen der vormontierten Innensechskantschraube zu sichern. Bei Federn mit separaten Höhenverstellungen (keine Federbeine) ist ein Sichern des Gewinderings gegen verdrehen nicht notwendig.
Achtung! Das Anzugsdrehmoment (Innensechskantschraube) von max. **1 - 2 Nm** muss in jedem Fall eingehalten werden.
9. Die Fahrwerkskomponenten sind anhand der Fahrzeughersteller-Richtlinien zu montieren.
10. Alle nicht in dieser Anleitung vorgegebenen Anzugsdrehmomente sind aus den Unterlagen des Fahrzeugherstellers zu entnehmen und einzuhalten.
11. Nach kompletter Montage des Fahrwerks ist das Fahrzeug im Werkstattbereich auszurollen. Danach ist die Fahrzeughöhe zu prüfen und eine Korrektur gemäß Kundenwunsch durchzuführen.
Achtung! Das Maß Radmitte - Kotflügelunterkante in der vorbenannten Tabelle ist in jedem Fall einzuhalten. Weiterhin sind auch die Mindestabstände zur Fahrbahnoberfläche einzuhalten, die in der auf Seite 4 aufgeführten Tabelle beschrieben sind.
Achtung! Beim Einstellen ist zu berücksichtigen, dass sich das Fahrzeug im Fahrbetrieb um weitere 5 - 10 mm absenken kann.
12. Überprüfung der Freigängigkeit von Rädern und Bereifung zu den Federbeinen (Gewinderingen) sowie anderen Fahrwerks- und Karosserieteilen. Das Mindestabstandsmaß darf **5 mm** nicht unterschreiten. Es ist gegebenenfalls mittels handelsüblicher (für das Fahrzeug zugelassen) Distanzscheiben mit eigenem Gutachten oder fachgerechter Bearbeitung der Radläufe wieder herzustellen. Bei Federbeinkonstruktionen, bei denen sich Federbeine direkt neben dem Rad befinden, die aber keine Rad führende Eigenschaft haben, ist das Fahrzeug mittels 100 mm hohen Unterlegkeilen über die Diagonale (z.B. vorne rechts und hinten links) einzufedern. In dieser Position muss nun das vorgegebene Mindestabstandsmaß auch eingehalten werden. Durch diese Maßnahme kann auch die Freigängigkeit der Bereifung zur Karosserie überprüft werden.
Achtung: Bei Verbundlenkerachsen ist diese Methode zur Beurteilung der Radfreigängigkeit zur Karosserie nicht ausreichend. Hier muss das Fahrzeug bis zur maximalen Achslast beladen werden und im Fahrversuch die Radfreigängigkeit überprüft werden.
13. Die Fahrwerksgeometrie ist gemäß Vorgaben des Fahrzeugherstellers neu einzustellen. Sollten die Werte aufgrund einer erheblichen Höhenabweichung nicht einstellbar sein, so ist ein optimaler Wert in Nähe des Toleranzbereiches des Fahrzeugherstellers einzustellen.
14. Abschließend müssen noch alle mit der Fahrzeughöhe in Verbindung stehenden Komponenten (z.B. Scheinwerfer, Bremskraftregler usw.) gemäß Vorgaben des Fahrzeugherstellers eingestellt werden.
15. Bei Fahrzeugen mit ESP bzw. DSC, EPC, etc. kann ein Eintrag im Fehlerspeicher in Verbindung mit Aufleuchten der Fehlerlampe aufgrund der neuen Fahrwerkskomponenten erfolgen. Je nach Marke und Modell kann dies ein sporadischer Fehler sein, der nach einer Probefahrt von ca. 5 km erlöschen kann. Bei einzelnen Modellen müssen zusätzlich beide Lenkendanschläge im Stand erreicht werden. Bei aktuellen Modellen ist u. U. eine Grundeinstellung der ESP-Funktion und des Lenkwinkels über den Diagnosetester des Fahrzeugherstellers notwendig.
16. Bei Fahrzeugen mit Fahrerassistenzsystemen muss im Falle einer Tieferlegung mit vergrößerten Einfederwegen, die korrekte Justierung der relevanten Sensoren (z.B. Radarsensor und Kamerasysteme) gemäß Herstellervorgaben nachgewiesen sein.

Danger:

Always follow the latest accident prevention regulations (not applicable for North America) for each step to prevent any serious bodily harm or injury.

1. We recommend the use of a vehicle hoist or lift when installing the suspension. If a lift is not available and jacking equipment is used, make sure that the vehicle is secured with commercial wheel blocks and jack stand to ensure safety.
2. The suspension components may only be installed by trained technical personnel using the proper tools.
3. The General Installation instructions, as well as the Technical Inspectorate documents must be read BEFORE attempting installation.
4. Never use impact wrenches or guns to install or remove shock absorber piston hardware.
5. Never disassemble or cut open shock absorbers and/or shock absorber inserts. They contain oil under pressure. Danger of explosion.
6. Before driving on public highways, carry out the work steps on page 7, items 11 through 14 after installation.
7. The suspension regulation (when available) needs to be disabled through an authorized dealer.
8. Please take care in any case that fittings (for example fittings of shock absorber housings or fittings of the lower control arm in the housing of the wheel bearing) are free of dust and oil. (see manufacturer guideline)

General Instructions for Use:

1. When adjusting the vehicle height, make sure that the threads are clean and free of debris. After initial cleaning, move the perch by 10 mm (0.4 Inches) downwards, and then clean the area that you desire to adjust the perch (up or down).
2. During height adjustments on separate shock and spring systems, remove the perch from the vehicle to adjust the height.
3. After adjusting the vehicle height, repeat steps 11 through 14 from page 7.
4. In the area of the piston rod and the sealing package of the new and used damper there might be oil and grease collected. This could either be caused by using a special black grease during assembling the washer or due to accumulation of streak oil. Further more oil is used during assembling the cartridge and rod guide. There is no reason of worrying about and damage, as in this area also dust and dirt used to be collected.

Tightening torque for the piston rod nut:

M8 = **25Nm (18 ft-lb)**, M10x1 = **20Nm (15 ft-lb)**, M10x1,25 = **20Nm (15 ft-lb)**, M12x1,25 = **35Nm (26 ft-lb)**,
M12x1,5 = **40Nm (29 ft-lb)**, M14x1,5 = **50Nm (37 ft-lb)**, M16x1,5 = **50Nm (37 ft-lb)**

General Mounting Specifications:

1. We recommend the use of a vehicle hoist or lift when installing the suspension.
2. **Caution:** If the vehicle is equipped with ride height sensors, they should be removed before removal of struts or dampers, otherwise damage may occur.
3. The struts should be removed as specified by manufacturer's instructions.
4. Manufacturer recommended tools for removal of the original struts, or a suitable spring compressor, must be used in order to remove most factory mounted suspension systems.
5. Mount the complete suspension system as described on the following pages.
6. Never use impact drivers to install nuts on the piston rods as permanent damage may occur. It is imperative that you do not damage the piston rod surface, through use of pliers etc, as the smallest damage will result in seal damage, and will not be covered under warranty.
7. Stay within the lowering range specified in the table on page 3.
Example: With a specified range of 20 - 60 mm (0.8 - 2.3 Inches), 40 mm (1.5 Inches) is your height adjustment range.
8. Ensure that the set screw on each spring collar is tightened to prevent movement of the spring perch. On vehicles with separate shock/spring combinations, no set screw is necessary.
Caution: Do not over tighten the set screw. Maximum torque is 1 - 2 Nm (0.74-1.47 ft-lb).
9. Install the suspension components in the vehicle as specified by the vehicle manufacturers in their document.
10. Except as noted, all torque values must comply with manufacturer recommended specifications.
11. After assembly and installation is complete, the vehicle should be rolled onto level ground. Once on level ground, measure the vehicle height and adjust to the customer's requirements, within the prescribed lowering range.
Caution: Wheel hub center—wheel arch maximum measurement in the table of page 3 must not be exceeded! Also take into account minimum road clearances specified in the table on page 7 (only valid for Germany!).
Caution: It is common for the vehicle suspensions to settle by an additional 5 - 10 mm (0.2 - 0.4 Inches)
12. Examine the clearance between the tires and the suspension over the full range of motion of the wheel. The minimum clearance between the suspension and the tire is 4 mm (0.16 Inches). If this clearance is less than 5 mm (0.2 Inches), wheel spacers may be necessary. With strut designs that are located close to the wheel, but that have no steering functions, use 100 mm (3.9 Inches) spacers on diagonally opposed wheel (e.g. front right, rear left). In this position, you must be able to achieve the minimum clearance required. You can also check the clearance between tire and body.
Caution: With torsion beam trailing arm axles, this method is not sufficient. The wheel must be under full load as well as test driven to properly calculate the clearances of 5 mm (0.2 Inches) from any other components.
13. The geometry of the suspension needs to be adjusted according the regulations of the vehicle manufacturer. If a value cannot be reached due to the difference in the height, a optimal value next to the tolerance range of the vehicle manufacturer needs to be adjusted.
14. All components that are controlled by vehicle ride height (e.g. headlights, brake bias regulator etc.) must be adjusted as specified by the vehicle manufacturer instructions and procedures.
15. For vehicles with ESP, DSC or EPC your new suspension components may cause an engine fault code to appear. This is only temporary as the vehicle electronics adjust to the new components/height. On some models this will end after driving approximately 3-5 miles, or through turning the steering wheel from full left to full right. On other models, this must be reset through the factory diagnostic port by a qualified technician.
16. If Vehicles have Driver Assistant Systems and the ride high is lowered by an increase of the compression travel, it must be proofed that all relevant sensors (like Radar Sensor or Camera Systems) be adjusted according to the Manufacture Specifications

Rear axle:

Struts and shock absorbers with rubber metal element may only be tighten when the vehicle is on wheels at stand height.



Install the factory top mount and secure it with the standard nut. Tightening torque for the piston rod nut is 50 Nm (37 ft-lb). In addition, the original seal and the cover must be refitted.

The strut unit has to be installed according to manufacturers instructions settings regarding tightening torque and fixing specifications.



Mount the rear axle adjustment between spring and chassis, the original spring supporting disc is not longer used. You have to remove the rear axle adjustment to correct

On damper versions with separate reservoirs, mount the reservoir facing the rear of the vehicle.

Intermediate ring

Helper spring



Use the supplied spring adapter at the bottom end of the spring.

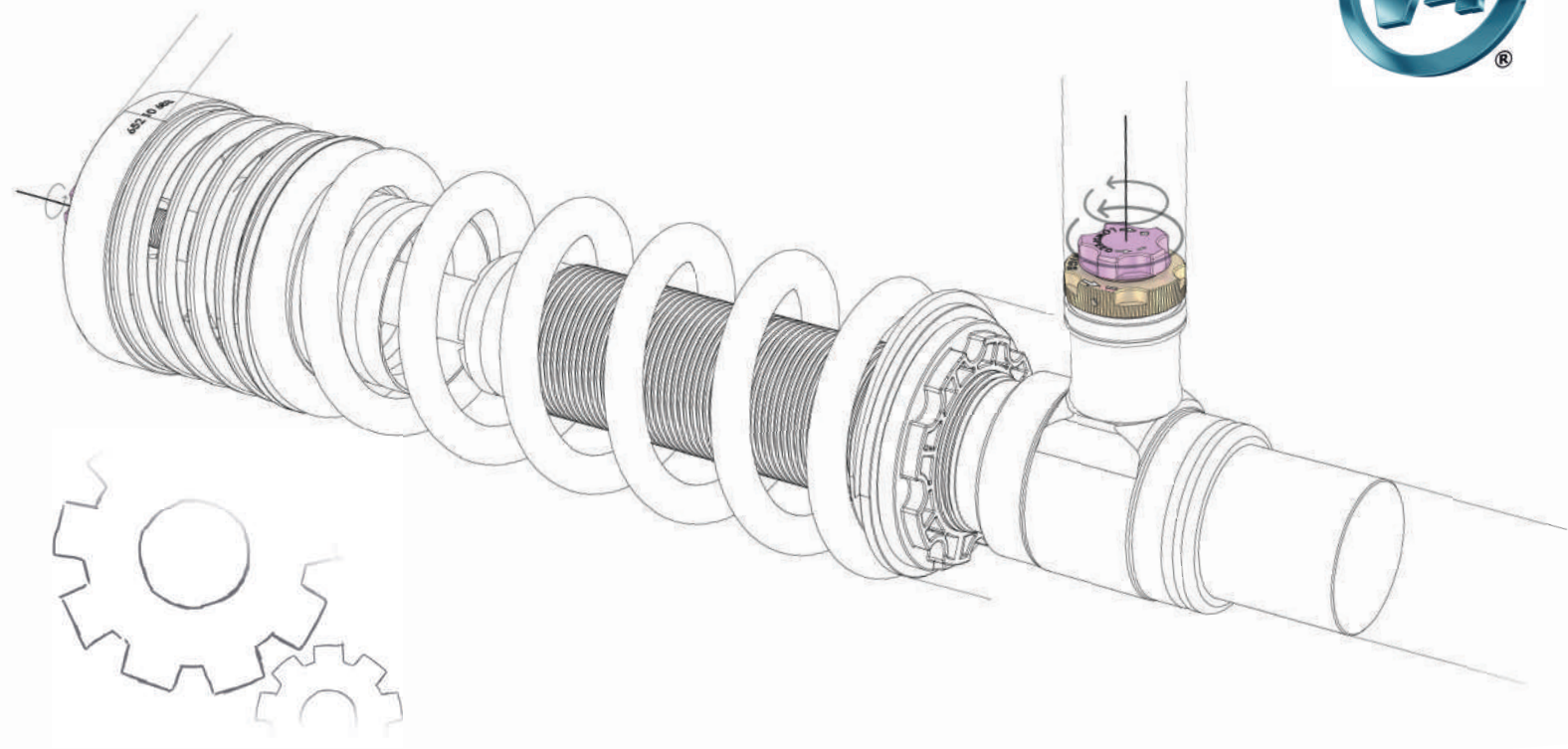

SETUP MANUAL



KW automotive

Set Up Manual KW V4

No. 685 79 423

Our 3-way adjustable damper is separate and independently adjustable in compression and rebound.

Rebound:

The rebound setting can be adjusted at the upper end of the piston rod via an adjustment wheel (version 1 and version 2)

In version 3 (upside-down version), the rebound adjuster is located at the lower end of the damper.

In all versions, the adjustment will be done based on closed status (max. hard). The closed status is reached when the adjustment wheel is completely turned to hard (+). ("0" on the adjustment wheel).

The effective adjustment range is 0 – 16 clicks open.

Never apply force to the adjusting mechanism of the shock absorber. As soon as you reach the end of the adjustment range, you will recognize a certain resistance. Stop turning to avoid damage to the bottom valve.

Impact of the rebound

Little rebound power improves driving comfort during slow driving, but reduces stability and control accuracy at fast driving, especially with appropriate adjustment.

High rebound power improves the handling at the front axle, but possibly reduces the grip. The driving comfort will be extremely limited.

Version 1 (Adjustment wheel for clipping on):

The adjustment wheel has to be put on the piston rod for adjusting the dampers. With clockwise rotation of the adjustment wheel the rebound damping will become harder. With anti-clockwise rotation the rebound damping will become softer. The click directions are labeled with "+" (harder) and "-" (softer) on the adjustment wheel.

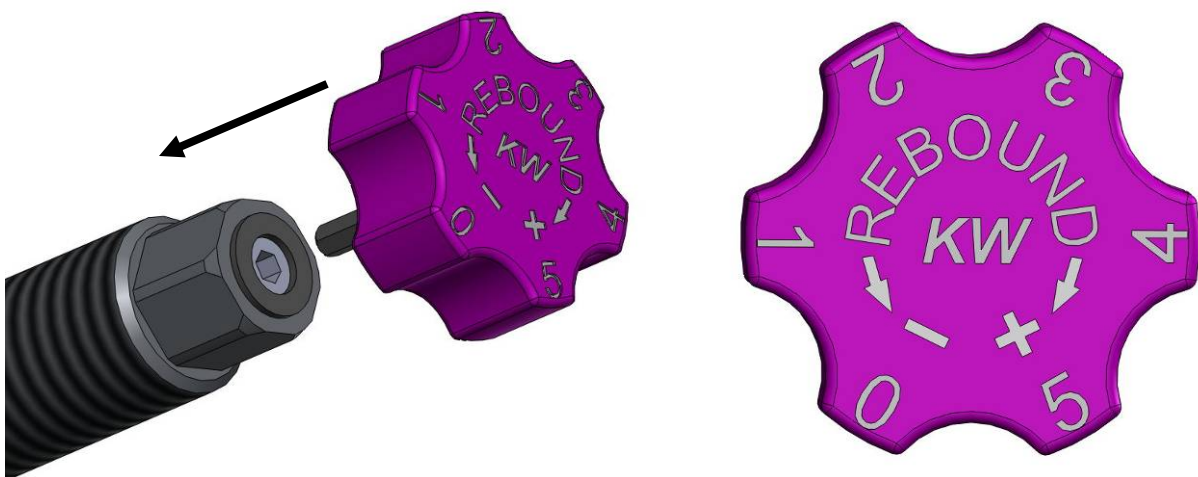

Version 2 (Integrated adjustability):

The numbers on the adjustment wheel show the current setup and facilitate the setup of the dampers. The click direction, in which the rebound becomes harder respectively softer, is marked on the adjustment header with a "+" (rebound becomes harder) and a "-" (rebound becomes softer). The numeration on the adjustment header is one sided. On the same side of the header, the valid adjustment stage can be found as a number on the adjustment wheel.

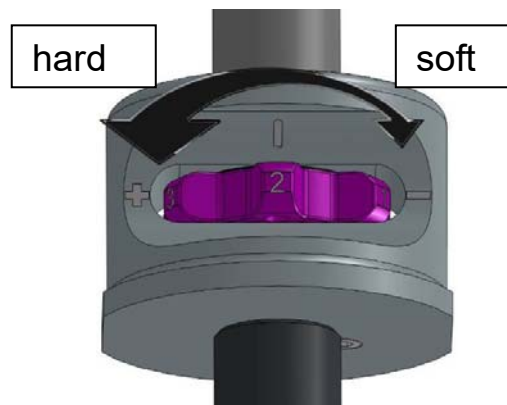
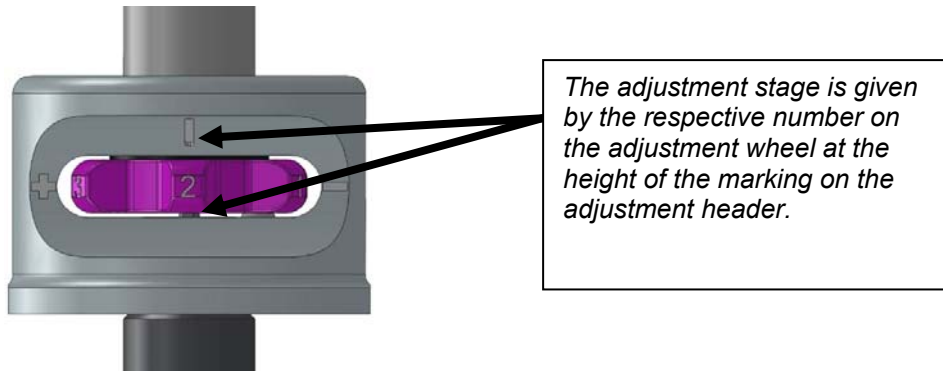
**Version 3 (Upside-down):**

The adjusting wheel is fixed to the bottom of the damper. With clockwise rotation of the adjustment wheel the rebound damping will become harder. With anti-clockwise rotation the rebound damping will become softer. The click directions are labeled with "+" (harder) and "-" (softer) on the adjustment wheel.

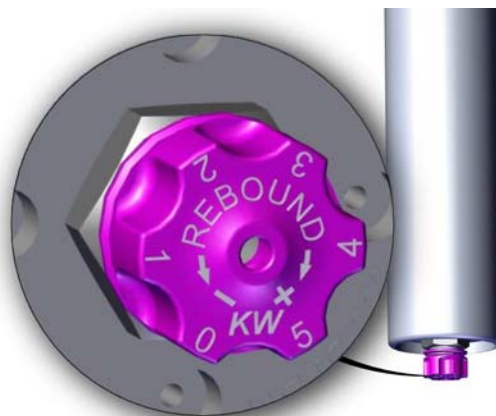
**Bump:**

The compression adjustment is done at the reservoir or the damper housing using the adjustment wheels. The adjustment will be done based on the closed valve (max. hard). The closed valve can be reached by turning the adjustment wheel completely too hard (+).

The maximum effective adjustment is 0 – 13 clicks in low speed and
0 – 14 clicks in highspeed.

Influence of low speed compression adjustment

Compression adjustment has significant influence on handling and driving behaviour.

In general there is to say:

A harder compression adjustment on the front axle makes the car more precise and more aggressive, whereas a softer adjustment favours a more forgiving steering behaviour.

Harder compression adjustment on the rear axle makes the car more stable on fast direction changes and helps if it has too much tendency to over steer. On the other hand, a softer compression damping makes the rear axle looser and might improve the handling if the car was too tight or had too much understeering before.

However, too much compression might cause uncomfortable and loud tyre role and/or costs grip.

Due to the digressive characteristic of the high speed section in our compression valve, hard adjustments do barely affect ride comfort on hard kerbs and bumps.

Never apply force to the adjusting mechanism of the shock absorber. As soon as you reach the end of the adjustment range, you will recognize a certain resistance. Stop turning to avoid damage to the bottom valve.

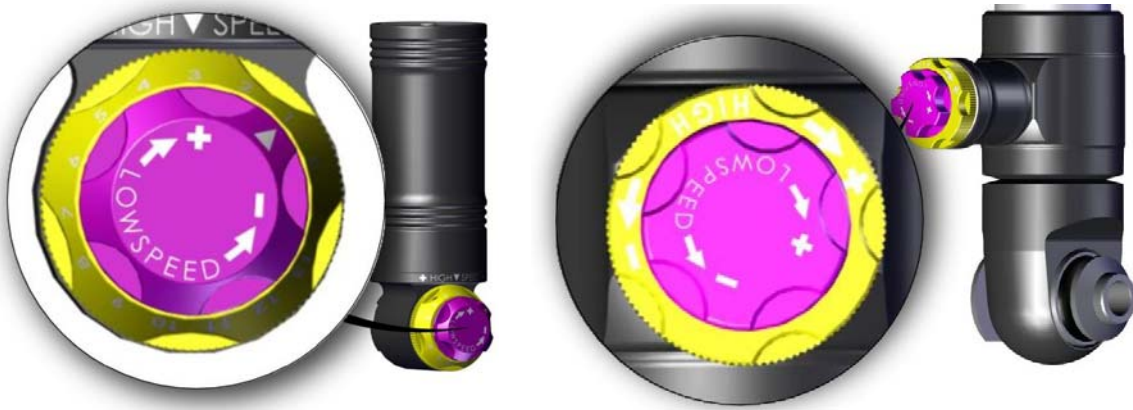
**Delivery status**

Our dampers will be delivered always in performance setup. This basic setup was specified for your car at the front and rear axle. In case of reset the dampers into the basic setup, the values of the following table are valid.

Our recommendation performance setup for your car to start with (delivery):

Front axle	Rebound:	6	Clicks open
-------------------	----------	---	-------------

Rear axle	Rebound:	7	Clicks open
------------------	----------	---	-------------

Front axle	Bump low:	4	Clicks open	Bump high:	9	Clicks open
-------------------	-----------	---	-------------	------------	---	-------------

Rear axle	Bump low:	3	Clicks open	Bump high:	12	Clicks open
------------------	-----------	---	-------------	------------	----	-------------

Our recommendation street setup for your car with:

Front axle	Rebound:	14	Clicks open
-------------------	----------	----	-------------

Rear axle	Rebound:	14	Clicks open
------------------	----------	----	-------------

Front axle	Bump low:	6	Clicks open	Bump high:	12	Clicks open
-------------------	-----------	---	-------------	------------	----	-------------

Rear axle	Bump low:	4	Clicks open	Bump high:	15	Clicks open
------------------	-----------	---	-------------	------------	----	-------------

Example: Adjusting the basic setup rebound front axle:

Basic setup rebound is 9 clicks opened in this example.

First, the rebound needs to be turned clockwise, direction "hard" (+). Afterwards, the adjustment wheel needs to be turned anti-clockwise, direction "soft" (-) until the adjustment wheel clicks 9 times.

The adjustment wheel now shows the number 3.

The single adjustment positions are described in the following chart.

