



## PARTS APPROVAL



# Parts Approval

Nr. / No. 1047/20  
vom / of 17.03.2020



**on the compliance of a vehicle when vehicle parts are properly installed  
and fitted to the car in accordance with § 19 Par. 3 No. 4 StVZO**

Modification

fbaus / Continuously adjustable suspension system for lowering  
the car body

Part type(s)

	... 10 0AP / ... 10 0BL	... 10 0BH / ... 10 0BM
	Achslast vorn / max. front axle load	
<b>Audi A4 Avant Frontantrieb</b>	bis 1145 kg to 1145 kg	-
<b>Audi A4 Limousine Quattro</b>	bis 1135 kg to 1135 kg	1136 kg bis/to 1215 kg
<b>Audi A5 Sportback Frontantrieb</b>	bis 1145 kg to 1145 kg	-
<b>Audi A5 Coupé Quattro</b>	bis 1135 kg to 1135 kg	1136 kg bis/to 1195 kg
<b>Audi S4 Limousine</b>	-	bis 1240 kg to 1240 kg

Manufacturer : KW automotive GmbH  
Aspachweg 14  
D-74427 Fichtenberg

Vehicle Manufacturer / Type(s) : Audi / B8, B81

max. axle load : VA (front axle) siehe Zuordnung / see allocation  
HA (rear axle) 1215 kg / bei Anhängerbetrieb + 80 kg  
for trailer operation + 80 kg

## 0. Instructions for vehicle owner

### Performance and confirmation without delay of modification acceptance

With the modification the type approval of the vehicle will expire if the modification acceptance provided for in StVZO § 19 Par. 3 is not performed and confirmed without delay or if conditions laid down are not complied with.

After performance of the technical modification, the vehicle must be pre-sented without delay together with the present TÜV parts approval to an officially recognised inspector at a Technical Inspection Centre or to an inspection engineer from an officially recognised inspection organisation to perform and confirm the specified modification acceptance.

# Parts Approval

Nr. / No. 1047/20  
vom / of 17.03.2020



## Compliance with Conditions and Notes

The Conditions and Notes given in III. and IV. must be complied with.

## Availability of documents

After the acceptance procedure the certificate with confirmation of the modification acceptance must be carried in the car and presented to authorised persons on demand; this will not apply once the vehicle documents have been amended.

The vehicle owner must apply, in accordance with the provision in the confirmation of modification acceptance, for the competent licensing authority to amend the veh. documents (vehicle registr. documents).

Further conditions can be found in the confirmation of modification acceptance.

## I. Field of application

Vehicle manufacturer	Trade name	Vehicle type	Variants and versions	Type approval
Audi	A4 Avant (B9)	B8	only station wagon with front wheel drive, except „g-tron“	e1*?/?*0430*.. valid from amendment 35
		B81		e13*?/?*1084*.. valid from amendment 19
	A4 Limousine (B9)	B8	only sedan car with four wheel drive	e1*?/?*0430*.. valid from amendment 35
	A5 Sportback (B9)	B8	only sportback with front wheel drive, except „g-tron“	e1*?/?*0430*.. valid from amendment 45
		B81		e13*?/?*1084*.. valid from amendment 29
	A5 Coupé (B9)	B8	only coupe with four wheel drive	e1*?/?*0430*.. valid from amendment 43
	S4 Limousine (B9)	B8	all	e1*?/?*0430*.. valid from amendment 43

# Parts Approval

Nr. / No. 1047/20  
vom / of 17.03.2020



The part of the EC type approval number showing \*?/?\* merely document the current status of the framework directive and are of no significance for this parts approval as long as the parts of the vehicle which are relevant to the lowering of the bodywork have not changed.

## II. Description of the modification

Front axle Part types ... 10 0AP / ... 10 0BL

	<b>Pre spring</b>	<b>Main spring</b>
Marking	5-80-70	80-70-250*
Corrosion protection	imprinted EPS-powder coating	imprinted EPS-powder coating
Wire size	7,4 x 4,4 mm	13,4 mm
Outer diameter	oben / top - mm mitte / middle 96 mm unten / bottom - mm	- mm 98 mm mm
Untensioned height	70 mm	250 mm
Number of coils	4,4	7,45
Coil shape	Cylinder, head(s) baselined	Cylinder, head(s) baselined
pring characteristic	linear	linear

	<b>Spring cup seat (top)</b>	<b>Spring cup seat (bottom)</b>
Max. diameter	100 mm	90 mm
Diameter rest	81 mm	71 mm
Height	24 mm	27 mm
Spring height adjustment	Infinitely adjustable cup seat (Strut)	

	<b>Strut</b>
Damping adjustment (rebound/compression)	without / manual / elektronik (DDC)
Marking clamp-Ø 48,6 mm	100 1022
Marking clamp-Ø 53,0 mm	100 1020

	<b>Rubber or polyurethane foam element</b>
Bump stop	
High/Diameter	50/58 mm
Bump travel	extended by 5 mm

# Parts Approval

Nr. / No. 1047/20  
vom / of 17.03.2020



Front axle Part types ... 10 OBH / ... 10 OBM

	<b>Pre spring</b>	<b>Main spring</b>
Marking	5-80-70	100-70-250*
Corrosion protection	imprinted EPS-powder coating	imprinted EPS-powder coating
Wire size	7,4 x 4,4 mm	14,4 mm
Outer diameter	- mm	- mm
oben / top	96 mm	100 mm
mitte / middle	- mm	mm
unten / bottom	70 mm	250 mm
Untensioned height	4,4	7,65
Number of coils	Cylinder, head(s) baselined	Cylinder, head(s) baselined
Coil shape	linear	linear
Spring characteristic		

	<b>Spring cup seat (top)</b>	<b>Spring cup seat (bottom)</b>
Max. diameter	100 mm	90 mm
Diameter rest	81 mm	71 mm
Height	24 mm	27 mm
Spring height adjustment	Infinitely adjustable cup seat (Strut)	

	<b>Strut</b>
Damping adjustment (rebound/ compression)	ohne / manuell / elektronisch (DDC) without / manual / electronic (DDC)
Marking clamp-Ø 48,6 mm	100 1022
Marking clamp-Ø 53,0 mm	100 1020

	<b>Rubber or polyurethane foam element</b>
Bump stop	
High/Diameter	50/58 mm
Bump travel	extended by 5 mm

# Parts Approval

Nr. / No. 1047/20  
vom / of 17.03.2020



## Rear axle

	<b>Pre spring</b>	<b>Main spring</b>
Marking	<i>non existent</i>	1055
Corrosion protection		<i>imprinted EPS-powder coating</i>
Wire size		14,9 mm
Outer diameter		92 mm
oben / top		120 mm
mitte / middle		81 mm
unten / bottom		225 mm
Untensioned height		7
Number of coils		
Coil shape		<i>Cylinder, head(s) baselined</i>
Spring characteristic		progressiv

	<b>Spring cup seat (top)</b>	<b>Spring cup seat (bottom)</b>
Max. diameter	80 mm	Serie OEM part
Diameter rest	61 mm	
Height	28 mm	
Spring height adjustment	<i>Infinitely adjustable cup seat (Bushing)</i>	

	<b>Shock absorber</b>
Damping adjustment (rebound/ compression)	<i>without / manual / elektronik (DDC)</i>
Marking	100 1120

	<b>Rubber or polyurethane foam element</b>
Bump stop	
High/Diameter	65/50 mm ww. 65+15/50
Bump travel	<i>extended by 5 mm</i>

### III.

#### **Notes on possible combination with other modifications**

#### **III. 1 Wheel/tyre combinations**

*There are no technical objections against the use of all O. E. wheel/tyre combinations.*

*If other wheel-/ tyre combinations are used, the examination in accordance with § 21 German Road Traffic Licensing Code – StVZO must be carried out by an officially recognised expert.*

#### **III. 2**

#### **Aerodynamic devices, special exhaust systems etc.**

*The dynamic ground clearance is decreased by the provision of special springs/dampers which increase the bump travel of the front and rear axle. In the case of the test vehicle, the min. ground clearance of 80 mm is complied with (below front axle). Care must be taken when driving over humps, barriers and heightened paving or road surfaces.*

*If special spoilers, aprons and exhaust systems are mounted, attention must be paid to the decreased overhang angle (driving up ramps etc.).*

### **IV. Conditions and Notes**

#### **Conditions and notes 6ft he6 installation shop and modification acceptance**

*Mounting 6ft he vehicle bodywork components will be performed in accordance with the vehicle manufacturer's specifications which must be included in the delivery and should be carried out by a specialist shop.*

*The headlight adjustment has to be checked.*

*After modification an axle alignment must be carried out on the vehicle.*

# Parts Approval

Nr. / No. 1047/20  
vom / of 17.03.2020



der auf Seite 1 dieses Teilegutachtens angegebene Höchstwert nicht überschritten werden. /  
*In case there are shown increased rear axle loads during trailer operation in the vehicle documents, this can still be continued after the installation. Please note that the maximum value of axle load mentioned on page 1 of this part certificate may not be exceeded.*

*The bump stops (rubber or polyurethane foam element) must correspond to the descriptions of this report. Additional travel limiters are not allowed.*

- *be deactivated by the use of "KW simulating plugs" respectively by changing the software or*
- *to be connected with the plugs of the serial dampers via the "KW connectors" of the KW dampers. The simulating plugs which optionally can be used, consist of a plug-in sleeve with an integrated electric coil. These plugs are to be connected with the vehicle-mounted connectors instead of the serial dampers in order to simulate the situation that the serial ones would still be installed, furthermore in order to rule out an error signal.*

*Use of the lowering kit on vehicles with levelling system is not permitted.*

*The optional installed Dynamic Damping Control (DDC) was tested with regard to the electromagnetic compatibility (EMC), the system stability and the driving dynamics. The damping characteristic is adjustable in three steps.*

*The vehicle height must be laid down in the vehicle documents in box 20. The precise measure of the lowering will depend on the specific vehicle tolerances, tyre size and vehicle version.*



# Parts Approval

Nr. / No. 1047/20  
vom / of 17.03.2020



dimensions (mm)

Vehicle type	adjustment range (min. – max.)		Clearance		Size of lowering	
	VA/front <sup>1)</sup>	HA/rear <sup>2)</sup>	VA/front <sup>3)</sup>	HA/rear <sup>3)</sup>	VA/front	HA/rear
Audi A4 Avant, Audi A5 Sportback	170 – 190	17 – 37	335	335	35 – 60	35 – 60
Audi A4 Limousine Quattro Teile-Typen / Part types ... 10 0AP / ... 10 0BL	165 – 185	18 – 38	335	335	30 – 55	35 – 60
Audi A4 Limousine Quattro Teile-Typen / Part types ... 10 0BH / ... 10 0BM	155 – 175	18 – 38	335	335	30 – 55	35 – 60
Audi A5 Coupé Quattro Teile-Typen / Part types ... 10 0AP / ... 10 0BL	165 – 185	13 – 33	335	335	40 – 65	40 – 65
Audi A5 Coupé Quattro Teile-Typen / Part types ... 10 0BH / ... 10 0BM	155 – 175	13 – 33	335	335	40 – 65	40 – 65
Audi S4 Limousine	160 – 180	19 – 39	335	335	10 – 35	10 – 35

1) Distance from the spring rest to the nearest fastening screw

2) Distance from contact point of the car to the adjustable spring perch

3) Minimum distance from wheel centre to wheelhouse rim

Amendment of vehicle documents:

Amendment of the vehicle documents is only necessary the next time the approval authority has to do with the vehicle documents. The following example is suggested for the entry:

Item	EEntry
22	Mit stufenlos verstellbarem Fahrwerk der Fa. KW automotive GmbH; Kennz. Federn vorn: 5-80-70 / 80-70-250*, hinten: 1055; Federbein vorn: 100 1022, Dämpfer hinten: 100 1120; Maß Radmitte bis Radhausauschnittkante VA/HA.../... *

## V. Basis of tests and test results

The test vehicle and the modification parts were subjected to a test in accordance with the test conditions regarding raising / lowering of vehicles contained in VdTÜV Merkblatt 751 (26.01.2018).  
The test conditions were fulfilled.

# Parts Approval

Nr. / No. 1047/20  
vom / of 17.03.2020



**VI.** Annex: none

## **VII. Concluding certification**

*It is hereby certified that the vehicles described under field of application satisfy the regulations of StVZO in the current version after modification and performed and confirmed modification acceptance, provided the conditions/notes given in the present TÜV approval are observed.*

*The manufacturer KW automotive GmbH maintains a quality management system according to ISO 9001:2015 (Certificate Registration No.: 12 100 22913 TMS).*

*he parts approval may only be reproduced and passed on by the manufacturer in its unabbreviated form.*

*The TÜV parts approval shall cease to be valid if technical modifications are made to the vehicle part or if modifications made to the vehicles described affect use of the part and in the case of any changes to the statutory specifications.*



# INSTALLATION INSTRUCTIONS



# *KW automotive*

## **INSTALLATION INSTRUCTIONS**

**Before you begin installation,  
please read the following carefully:**

- **Ensure that the certificate matches the vehicle specifications (front vehicle identification number (VIN)) etc...**
- **The suspension components must match the suspensions application specifications (springs and shock/struts identification numbers).**
- **The instructions have to be strictly observed.**

KW Coilovers for automobile suspensions are designed for easy installation. If not otherwise stipulated in these instructions, all suspension components are installed and removed in accordance with the manufacturer's specifications for installing and removing standard springs and damper components. At the time of printing all instructions and specifications are correct.

Technical data	Coilover part number ... 10 0BH			
Vehicle model	Audi A5 Coupé Quattro (B9) type B8, B81		max. permissible front axle load: 1136 - 1195 kg	
	front axle		rear axle	
Spring signature	5-80-70 / 100-70-250*		1055	
Coilover strut / Shock absorber signature	100 1020		100 1120	
Approximate distance measurement A Front axle: Fastening screw - spring contact area Rear axle: Seating height adjustment - spring contact area or fastening screw - spring contact area	min:	max:	min:	max:
	155 mm / 6,1 inch	175 mm / 6,9 inch	13 mm / 0,51 inch	33 mm / 1,3 inch
Approximate measurement* B in mm / inch: wheel hub center to fender edge	min:		min:	
	335 mm / 13,2 inch		335 mm / 13,2 inch	

Vehicle model	Audi S4 sedan (B9) type B8		max. permissible front axle load: - 1240 kg	
	front axle		rear axle	
Spring signature	5-80-70 / 100-70-250*		1055	
Coilover strut / Shock absorber signature	100 1020		100 1120	
Approximate distance measurement A Front axle: Fastening screw - spring contact area Rear axle: Seating height adjustment - spring contact area or fastening screw - spring contact area	min:	max:	min:	max:
	160 mm / 6,3 inch	180 mm / 7,1 inch	19 mm / 0,75 inch	39 mm / 1,54 inch
Approximate measurement* B in mm / inch: wheel hub center to fender edge	min:		min:	
	335 mm / 13,2 inch		335 mm / 13,2 inch	

Vehicle model	Audi A4 sedan Quattro (B9) type B8		max. permissible front axle load: 1136 - 1215 kg	
	front axle		rear axle	
Spring signature	5-80-70 / 100-70-250*		1055	
Coilover strut / Shock absorber signature	100 1020		100 1120	
Approximate distance measurement A Front axle: Fastening screw - spring contact area Rear axle: Seating height adjustment - spring contact area or fastening screw - spring contact area	min:	max:	min:	max:
	155 mm / 6,1 inch	175 mm / 6,9 inch	18 mm / 0,71 inch	38 mm / 1,5 inch
Approximate measurement* B in mm / inch: wheel hub center to fender edge	min:		min:	
	335 mm / 13,2 inch		335 mm / 13,2 inch	

**Calculating the adjustment range (distance measurement A) :** (Photos are examples only)

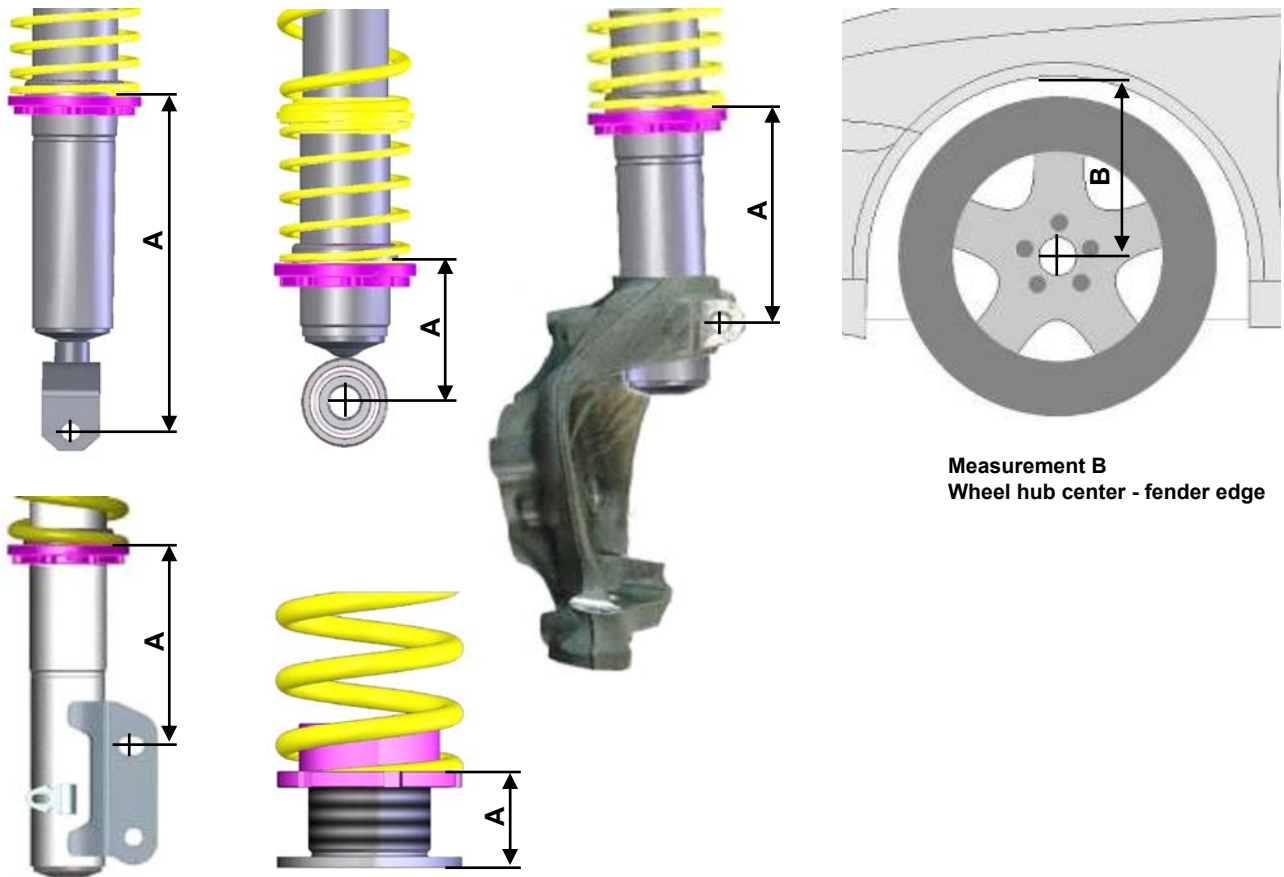

**Measurement B**  
Wheel hub center - fender edge

**Please enter the adjusted height of the modified car into the list:**

Coilover part no	Vehicle type	Measurement A		Wheel hub center - fender edge Measurement B	
		Front	Rear	Front	Rear

\* **IMPORTANT:** The allowable measurement between wheel hub center and fender edge as indicated above, may not exceed these measurements when using standard fenders.

**Danger:**

Always follow the latest accident prevention regulations (not applicable for North America) for each step to prevent any serious bodily harm or injury.

1. We recommend the use of a vehicle hoist or lift when installing the suspension. If a lift is not available and jacking equipment is used, make sure that the vehicle is secured with commercial wheel blocks and jack stand to ensure safety.
2. The suspension components may only be installed by trained technical personnel using the proper tools.
3. The General Installation instructions, as well as the Technical Inspectorate documents must be read BEFORE attempting installation.
4. Never use impact wrenches or guns to install or remove shock absorber piston hardware.
5. Never disassemble or cut open shock absorbers and/or shock absorber inserts. They contain oil under pressure. Danger of explosion.
6. Before driving on public highways, carry out the work steps on page 7, items 11 through 14 after installation.
7. The suspension regulation (when available) needs to be disabled through an authorized dealer.
8. Please take care in any case that fittings (for example fittings of shock absorber housings or fittings of the lower control arm in the housing of the wheel bearing) are free of dust and oil. (see manufacturer guideline)

**General Instructions for Use:**

1. When adjusting the vehicle height, make sure that the threads are clean and free of debris. After initial cleaning, move the perch by 10 mm (0.4 Inches) downwards, and then clean the area that you desire to adjust the perch (up or down).
2. During height adjustments on separate shock and spring systems, remove the perch from the vehicle to adjust the height.
3. After adjusting the vehicle height, repeat steps 11 through 14 from page 7.
4. In the area of the piston rod and the sealing package of the new and used damper there might be oil and grease collected. This could either be caused by using a special black grease during assembling the washer or due to accumulation of streak oil. Further more oil is used during assembling the cartridge and rod guide. There is no reason of worrying about and damage, as in this area also dust and dirt used to be collected.

**Tightening torque for the piston rod nut:**

M8 = **25Nm (18 ft-lb)**, M10x1 = **20Nm (15 ft-lb)**, M10x1,25 = **20Nm (15 ft-lb)**, M12x1,25 = **35Nm (26 ft-lb)**,  
M12x1,5 = **40Nm (29 ft-lb)**, M14x1,5 = **50Nm (37 ft-lb)**, M16x1,5 = **50Nm (37 ft-lb)**

## General Mounting Specifications:

1. We recommend the use of a vehicle hoist or lift when installing the suspension.
2. **Caution:** If the vehicle is equipped with ride height sensors, they should be removed before removal of struts or dampers, otherwise damage may occur.
3. The struts should be removed as specified by manufacturer's instructions.
4. Manufacturer recommended tools for removal of the original struts, or a suitable spring compressor, must be used in order to remove most factory mounted suspension systems.
5. Mount the complete suspension system as described on the following pages.
6. Never use impact drivers to install nuts on the piston rods as permanent damage may occur. It is imperative that you do not damage the piston rod surface, through use of pliers etc, as the smallest damage will result in seal damage, and will not be covered under warranty.
7. Stay within the lowering range specified in the table on page 3.  
**Example:** With a specified range of 20 - 60 mm (0.8 - 2.3 Inches), 40 mm (1.5 Inches) is your height adjustment range.
8. Ensure that the set screw on each spring collar is tightened to prevent movement of the spring perch. On vehicles with separate shock/spring combinations, no set screw is necessary.  
**Caution:** Do not over tighten the set screw. Maximum torque is 1 - 2 Nm (0.74-1.47 ft-lb).
9. Install the suspension components in the vehicle as specified by the vehicle manufacturers in their document.
10. Except as noted, all torque values must comply with manufacturer recommended specifications.
11. After assembly and installation is complete, the vehicle should be rolled onto level ground. Once on level ground, measure the vehicle height and adjust to the customer's requirements, within the prescribed lowering range.  
**Caution:** Wheel hub center—wheel arch maximum measurement in the table of page 3 must not be exceeded! Also take into account minimum road clearances specified in the table on page 7 (only valid for Germany!).  
**Caution:** It is common for the vehicle suspensions to settle by an additional 5 - 10 mm (0.2 - 0.4 Inches)
12. Examine the clearance between the tires and the suspension over the full range of motion of the wheel. The minimum clearance between the suspension and the tire is 4 mm (0.16 Inches). If this clearance is less than 5 mm (0.2 Inches), wheel spacers may be necessary. With strut designs that are located close to the wheel, but that have no steering functions, use 100 mm (3.9 Inches) spacers on diagonally opposed wheel (e.g. front right, rear left). In this position, you must be able to achieve the minimum clearance required. You can also check the clearance between tire and body.  
**Caution:** With torsion beam trailing arm axles, this method is not sufficient. The wheel must be under full load as well as test driven to properly calculate the clearances of 5 mm (0.2 Inches) from any other components.
13. The geometry of the suspension needs to be adjusted according the regulations of the vehicle manufacturer. If a value cannot be reached due to the difference in the height, a optimal value next to the tolerance range of the vehicle manufacturer needs to be adjusted.
14. All components that are controlled by vehicle ride height (e.g. headlights, brake bias regulator etc.) must be adjusted as specified by the vehicle manufacturer instructions and procedures.
15. For vehicles with ESP, DSC or EPC your new suspension components may cause an engine fault code to appear. This is only temporary as the vehicle electronics adjust to the new components/height. On some models this will end after driving approximately 3-5 miles, or through turning the steering wheel from full left to full right. On other models, this must be reset through the factory diagnostic port by a qualified technician.
16. If Vehicles have Driver Assistant Systems and the ride high is lowered by an increase of the compression travel, it must be proofed that all relevant sensors (like Radar Sensor or Camera Systems) be adjusted according to the Manufacture Specifications



**Front axle:**

Supplied coilover strut.

Following for vehicles without electronic damping control.

At vehicles without electronic damper control the installed bush is not needed and can be disposed of!

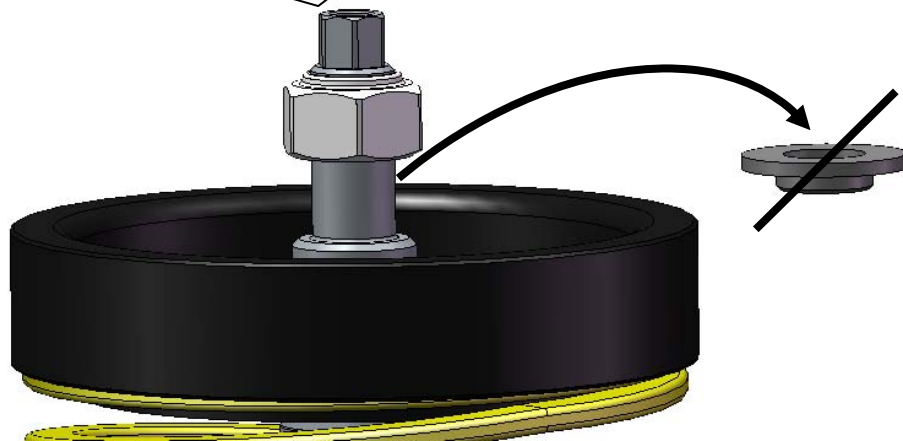
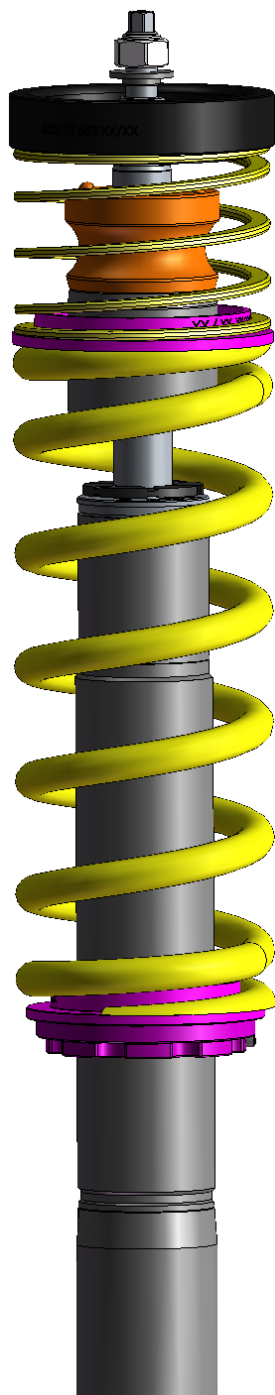

Push the supplied bump stop with dust cover into the original top mount.

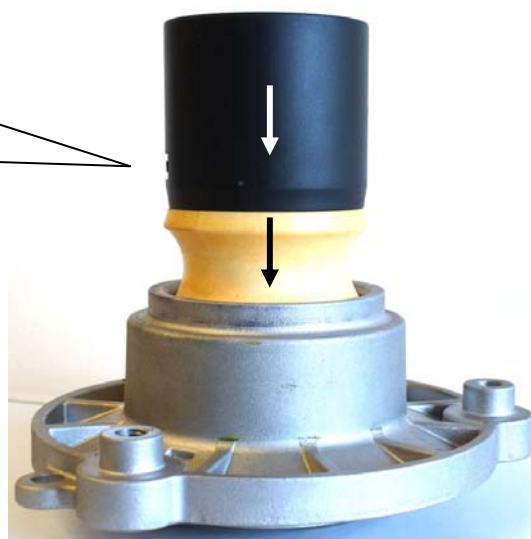

**Front axle:**

Install the factory top mount and secure it with the supplied nut. Tightening torque for the piston rod nut is 35 Nm (26 ft-lb). The strut unit has to be installed according to manufacturers instructions settings regarding tightening torque and fixing specifications.



Reinstall the original cover on the top mount.

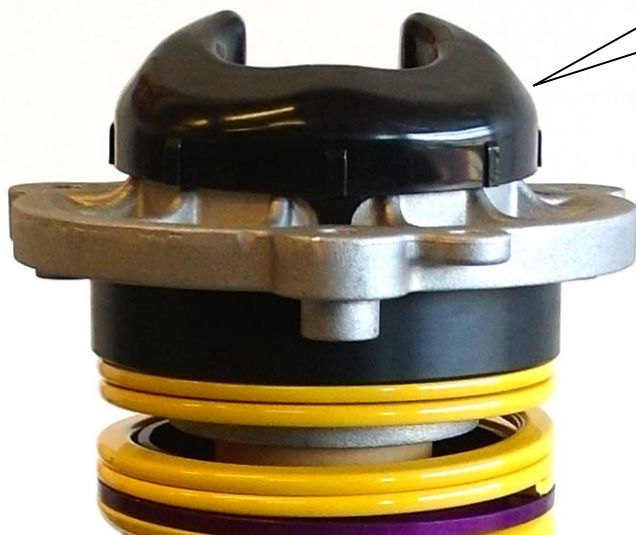

**Front axle:**

Supplied coilover strut.

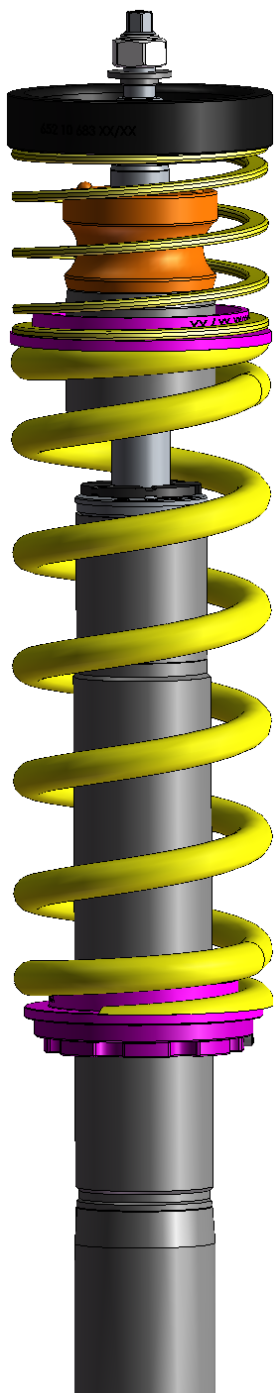

Following for vehicles with electronic damping control.

Push the supplied bump stop with dust cover into the original top mount.

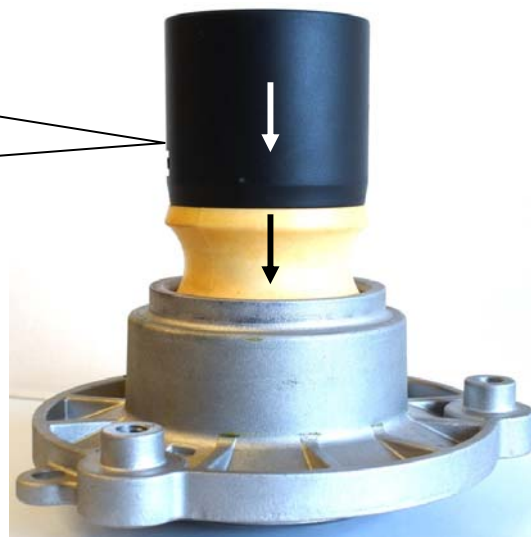

Insert / press in the plugged bush into the top mount.

Plugged bush

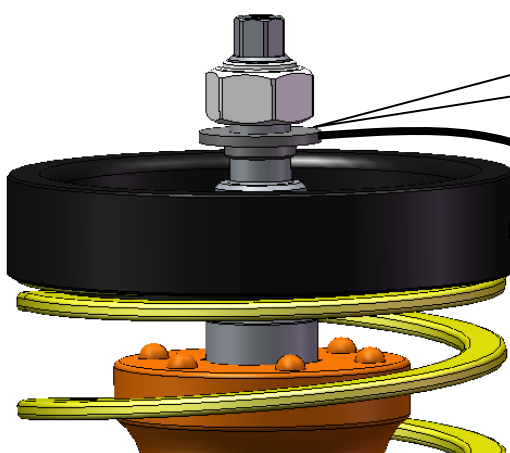

Picture shows the inserted bush into the OEM top mount.

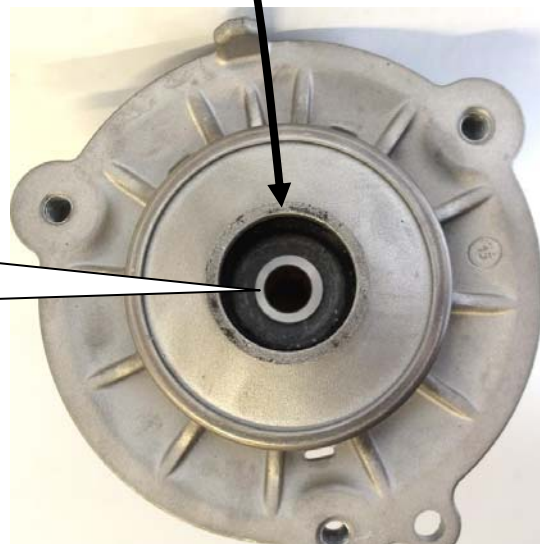

**Front axle:**

Install the factory top mount and secure it with the supplied nut. Tightening torque for the piston rod nut is 35 Nm (26 ft-lb). The strut unit has to be installed according to manufacturers instructions settings regarding tightening torque and fixing specifications.



Reinstall the original cover on the top mount.

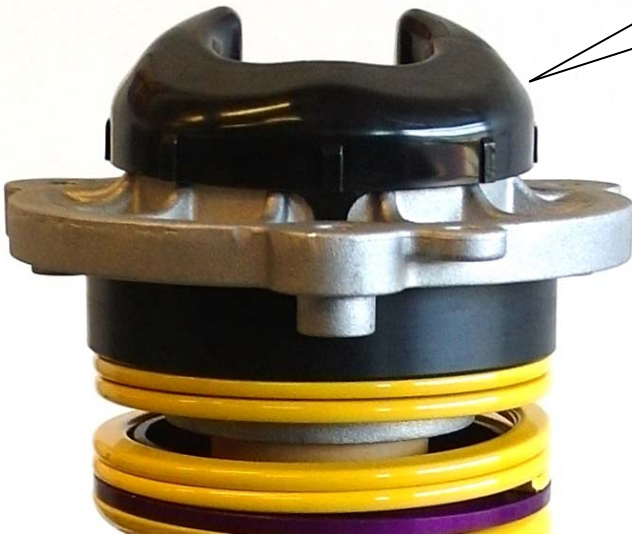

**Rear axle:**

Following for vehicles without electronic damping control.

At vehicles without electronic damper control the installed bush is not needed and can be disposed of!

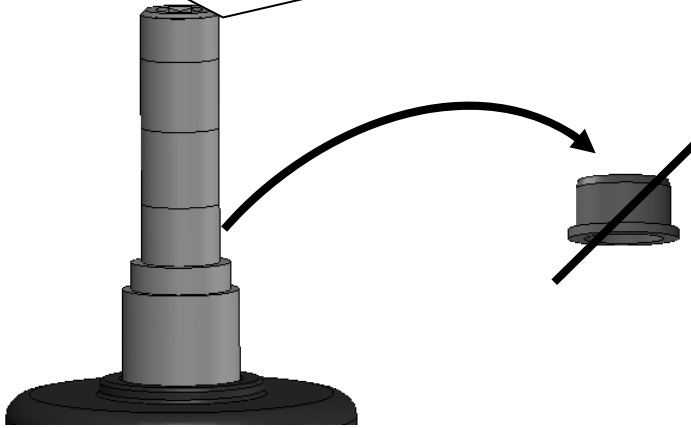

Following for vehicles with electronic damping control.

Insert / press in the plugged bush into the top mount.

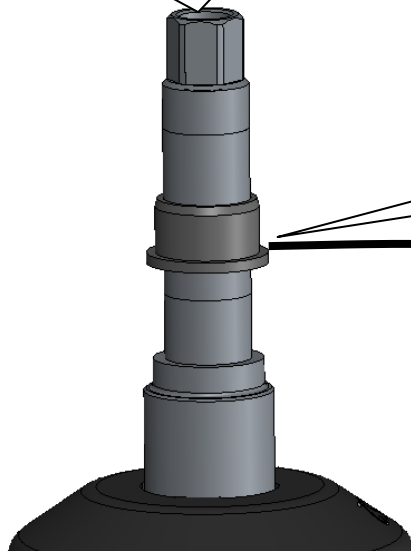

Picture shows the inserted bush into the OEM top mount.

**Rear axle:**

Install the factory supporting bearing and fix it with the supplied stop nut. Tightening torque for the piston rod nut is 20 Nm (15 ft-lb). The damper unit has to be installed according to manufacturers recommended settings regarding tightening torque and fixing specifications.

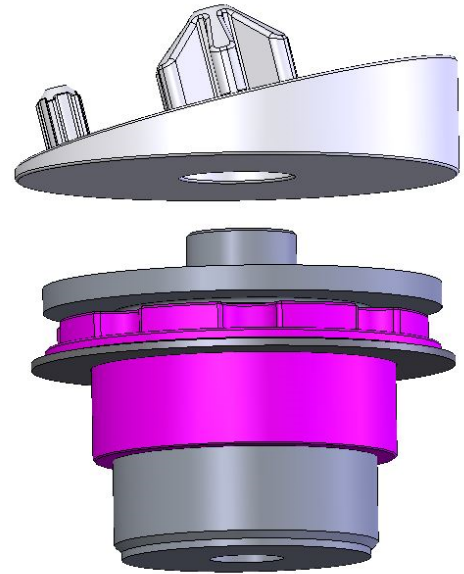

Mount the rear axle adjustment with the disc and the adapter between spring and chassis, the original spring support is no longer used. You have to remove the rear axle adjustment to correct (screw up the threaded ring) the car height.  
Attention: Before the installation of the height adjustment perch the touching surface area have to be cleaned.

On damper versions with separate reservoirs, mount the reservoir facing to the rear of the vehicle.

Use the original spring support at the bottom end of the spring.



# SETUP MANUAL



# KW automotive



## Set Up Manual KW-Variant 3

No. 685 80 082

Our 2-way adjustable competition shock absorber is based on the KW twin tube damping system, and features independent bump and rebound adjustment. Depending on the sealing and the adjusting system of the individual kit, our systems may be filled with pressures of 3 to 8 bars, or without any pressure at all.

### **Rebound:**

The rebound setting can be adjusted at the upper end of the piston rod via an adjustment wheel.

There are 2 different versions regarding the setting of the rebound. In version 1 the adjustment wheel will be put on the upper end of the piston rod. In version 2 the adjustment wheel is already mounted on the piston rod.

In both versions, the adjustment will be done based on closed status (max. hard). The closed status is reached when the adjustment wheel is completely turned to hard (+). ("0" on the adjustable wheel).

The effective adjustment range is 0 – 16 clicks open.

**Never apply force to the adjusting mechanism of the shock absorber. As soon as you reach the end of the adjustment range, you will recognize a certain resistance. Stop turning to avoid damage to the bottom valve.**

### **Impact of the rebound**

Little rebound power improve driving comfort during slow driving, but reduce stability and control accuracy while fast driving, especially with appropriate adjustment.

High rebound power improve the handling at the front axle, but possibly reduce the grip. The driving comfort will be extremely limited. In no case you should drive with one axle hard and one axle soft.



**Version 1 (Adjustment wheel for clipping on):**

The adjustment wheel has to be put on the piston rod. With clockwise rotation of the adjustment wheel the rebound damping will become harder. With anti-clockwise rotation the rebound damping will become softer. The click directions are labeled with "+" (harder) and "-" (softer) on the adjustment wheel.

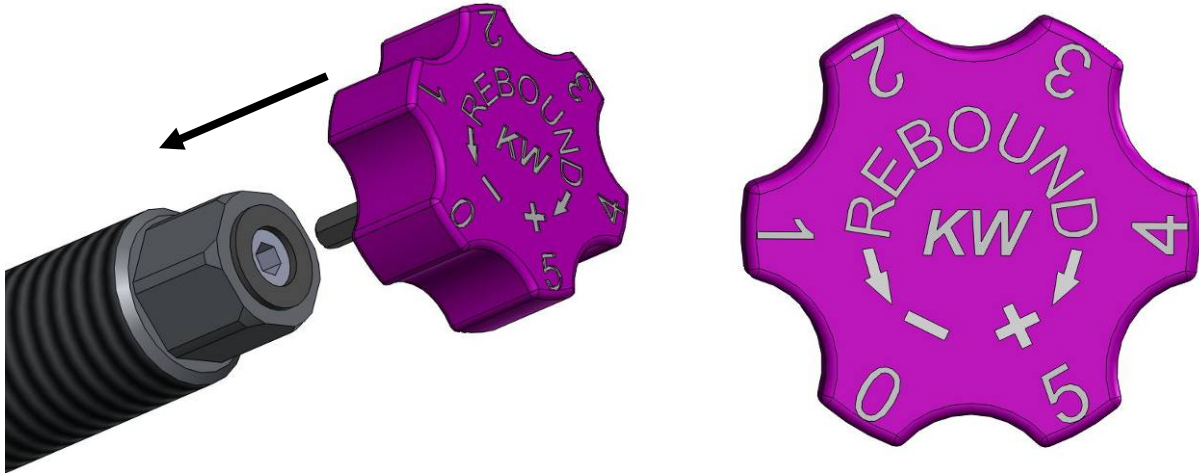
**Version 2 (Integrated adjustability):**

The numbers on the adjustment wheel show current setup and facilitate the setup of the dampers. The click direction, in which the rebound becomes harder respectively softer, is marked on the adjustment header with a "+" (rebound becomes harder) and a "-" (rebound becomes softer). Numeration on the adjustment header is one sided. The numbers of the adjustment wheel can be read on site with marks at the adjustment header. The data of the adjustment wheel can be read from the marks.

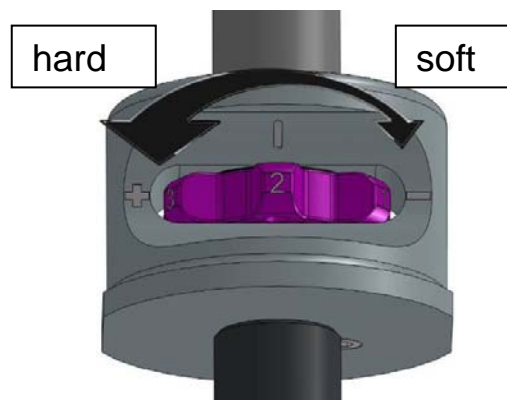
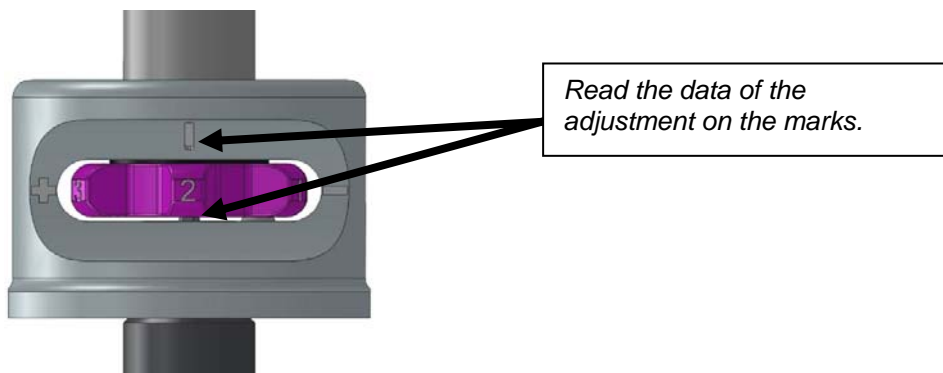

**Bump:**

Adjustment of compression damping takes place at the bottom of the damper, also with the support of the adjustment wheel. The adjustment will be done based on the closed valve (max. hard). The closed valve can be reached by turning the adjustment wheel completely to hard (+). The maximum effective adjustment is 0 – 12 clicks.

The maximum effective adjustment is 0 – 12 clicks.

**Influence of low speed compression adjustment**

Compression adjustment has significant influence on handling and driving behaviour.

General rules are:

A harder compression adjustment on the front axle makes the car more precise and more aggressive, whereas a softer adjustment favours a more forgiving steering behaviour.

Harder compression adjustment on the rear makes the car more stable on fast direction changes and helps if it has too much tendency to over steer. On the other hand, a softer rear compression makes the rear looser and might improve the handling if the car was too tight or had too much under steer before.

However, too much compression might cause uncomfortable and loud tyre role and/or costs grip.

Due to the digressive characteristic of the high speed section in our compression valve, hard adjustments do barely affect ride comfort on hard kerbs and bumps.

**Never apply force to the adjusting mechanism of the shock absorber. As soon as you reach the end of the adjustment range, you will recognize a certain resistance. Stop turning to avoid damage to the bottom valve.**

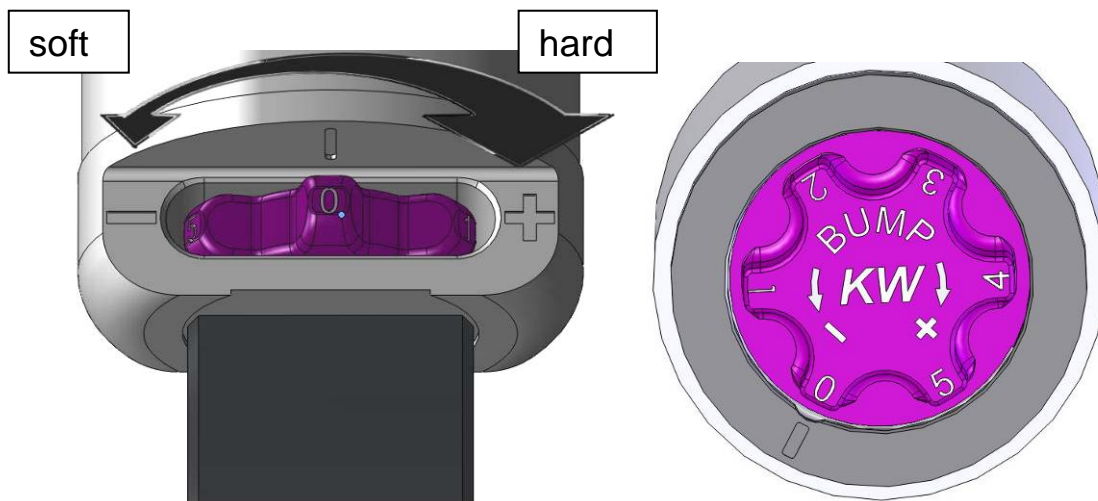
**Delivery status**

Our dampers will be delivered always in basic setup. This basic setup was specified for your car at the front and rear axle. In case of reset the dampers into the basic setup, the values of the table are valid.

<b>Front axle</b>	Rebound:	7 Clicks open	Bump:	6 Clicks open
<b>Rear axle</b>	Rebound:	9 Clicks open	Bump:	4 Clicks open

**Example: Adjusting the basic setup rebound front axle:**

Basic setup rebound is 9 clicks open.

First the rebound needs to be turned clockwise, direction "hard" (+). Afterwards, the adjustment wheel needs to be turned anti-clockwise, direction "soft" (-) until the adjustment wheel clicks 9 times.

The adjustment wheel now shows the number 3.

The single adjustment positions are described in the following chart.

