

..küat..

NVTM 2.0

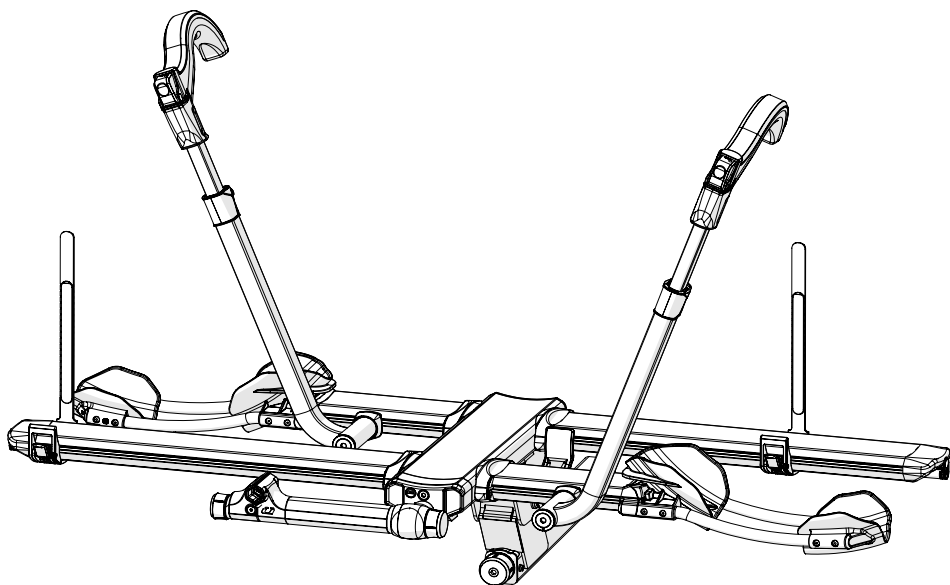

Parts:

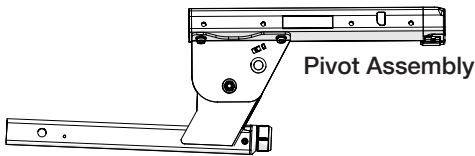
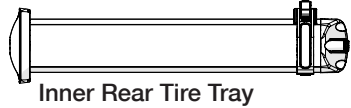
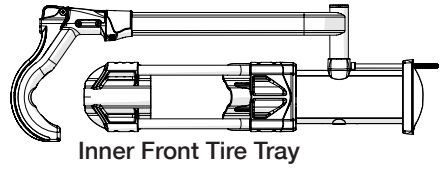
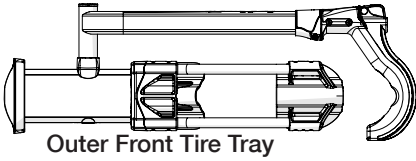

Included in the parts box:

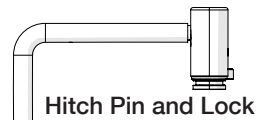
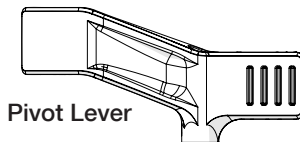
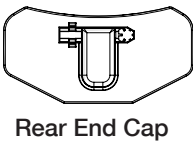
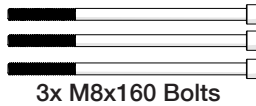

STEP 1. Throw the end cap lever open to release the Trail Doc™ Post and pull the Trail Doc™ Post completely out from the rear of the center-beam.

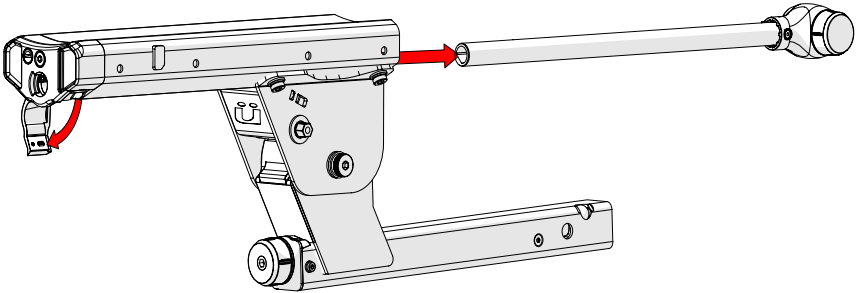

STEP 2. Insert rear end cap.

Part Needed:

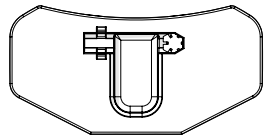

Rear End Cap

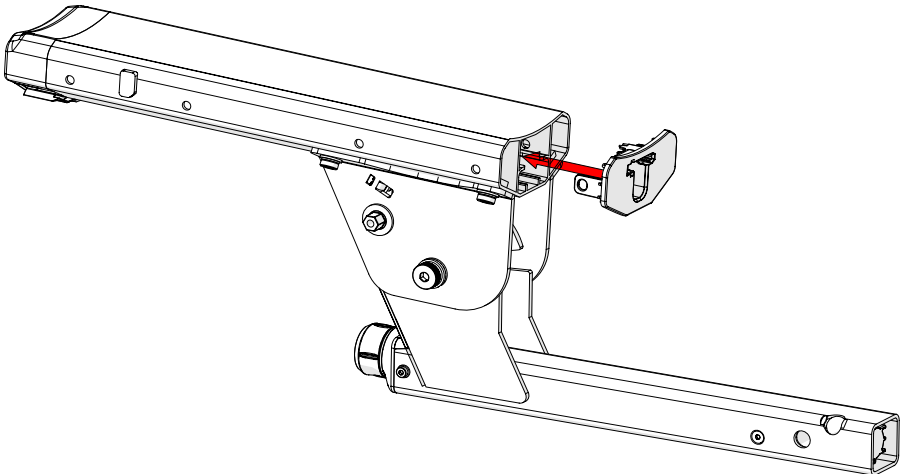

STEP 3. Align the trays with the holes on the center-beam by matching the coordinating labels. Then alternate between bolts to tighten.

Parts Needed:

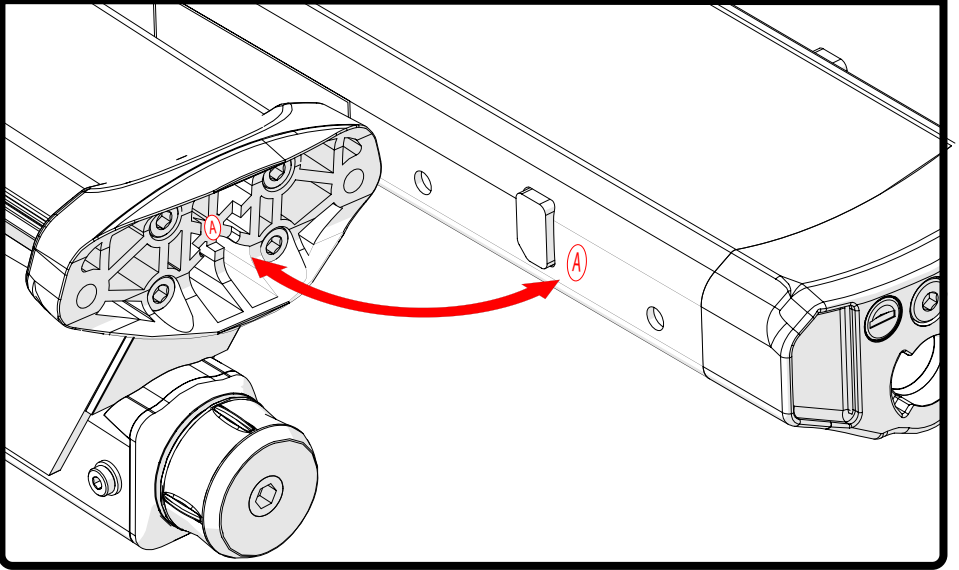
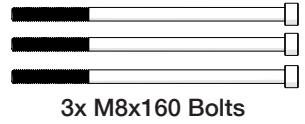

NOTE: The trays with the “..Küat..” Logo will be farthest from the hitch. Performing this step with the rack upside down will ease assembly.

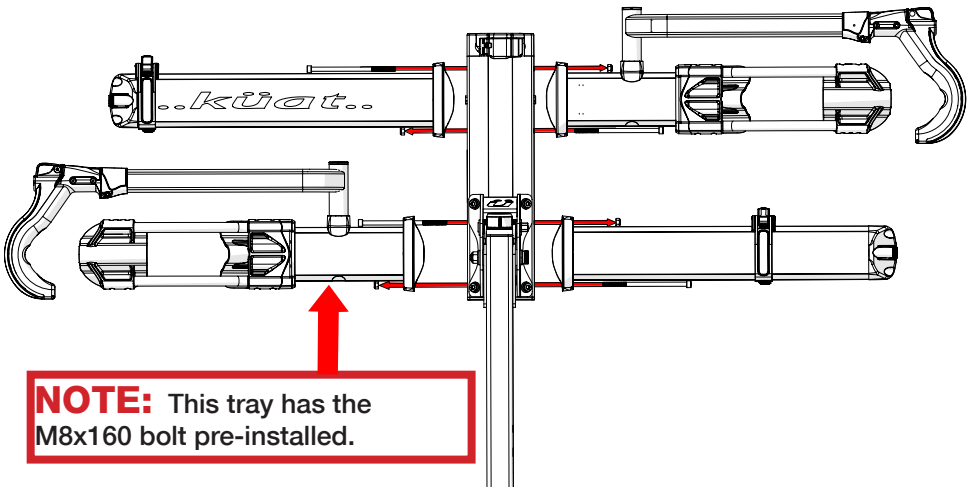

STEP 4. Press the pivot lever onto the corresponding keyed shaft. Then tighten the bolt with the lock washer to secure the pivot lever.

Parts Needed:



M6 Lock Washer



M6x22 Bolt

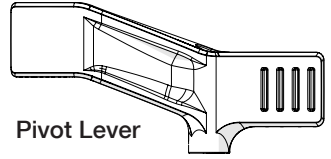

Pivot Lever

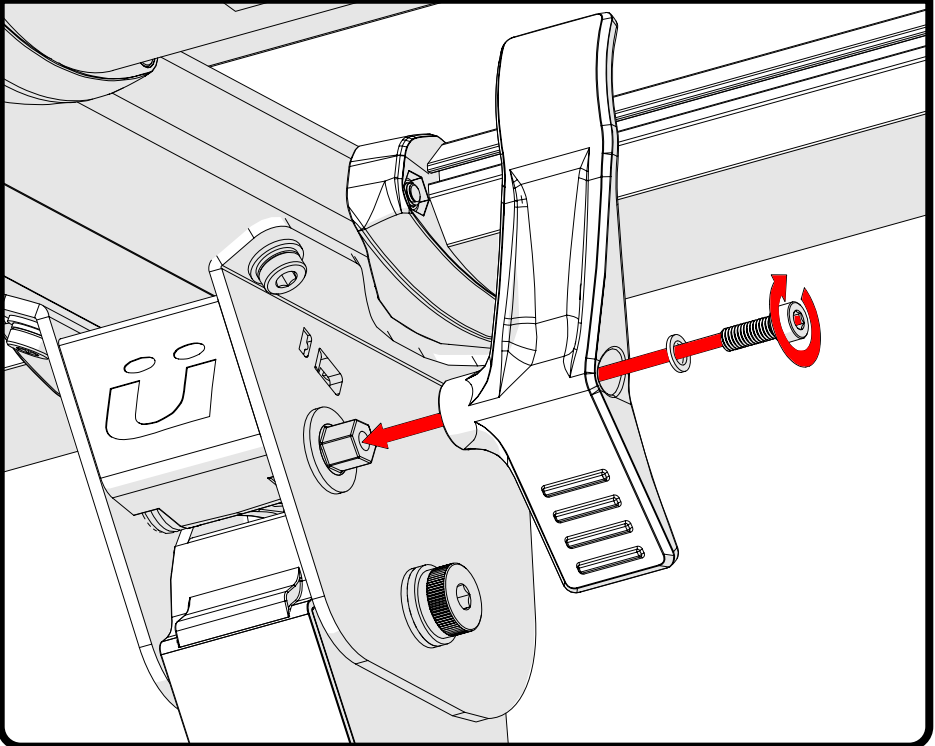

NOTE: When positioning the pivot lever there should be about 1in(25.4mm) of space between the lever and the tray.

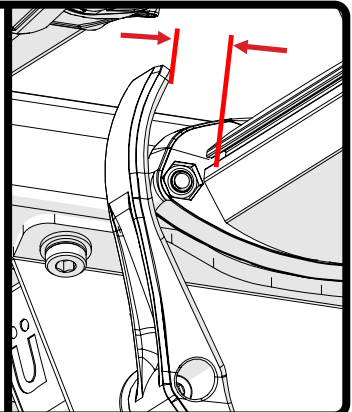

STEP 5. Thread the Trail Doc™ clamp onto the Trail Doc™ post.

Parts Needed:

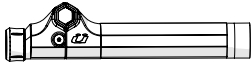

Trail Doc™ Clamp



Trail Doc™ Post

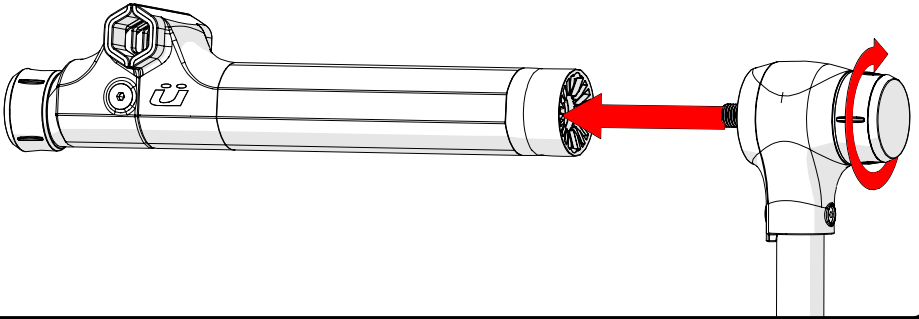

STEP 6. Open the lever on the end cap and insert the Trail Doc™.

NOTE: Use the end cap plug to keep debris out when the Trail Doc™ is not installed. The tension on the lever can be adjusted using a 3mm allen wrench.

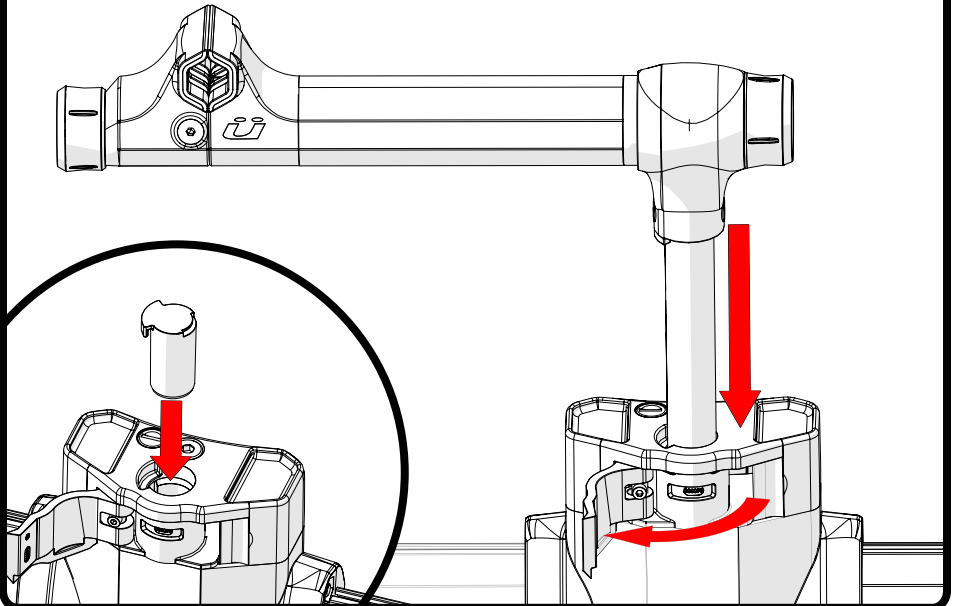

STEP 7. Insert the rack into the hitch receiver and align the hitch pin holes, then insert the hitch pin and lock. Push or pull the rack in the hitch receiver to remove rattle caused by the hitch pin and turn the knob until tight.

Parts Needed:

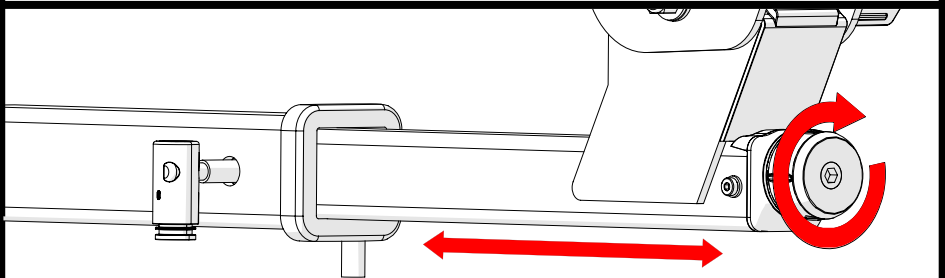
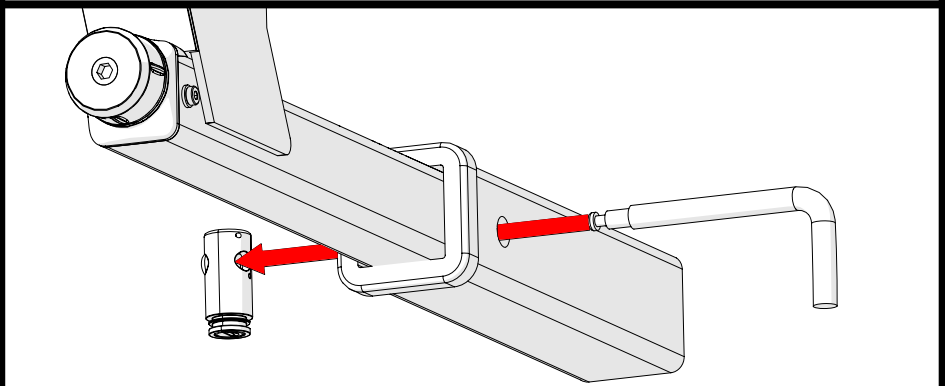
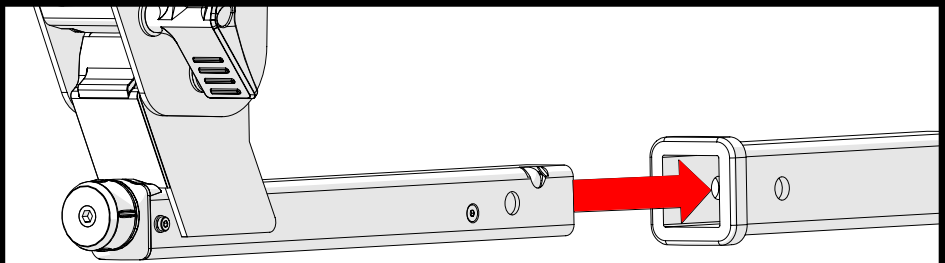
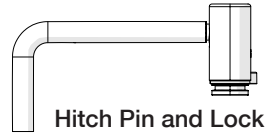

Loading bicycles:

STEP 1. Rotate the tire hook outward. Press the button and extend the hook.

NOTE: When not in use keep the tire hook rotated inward to avoid damage.

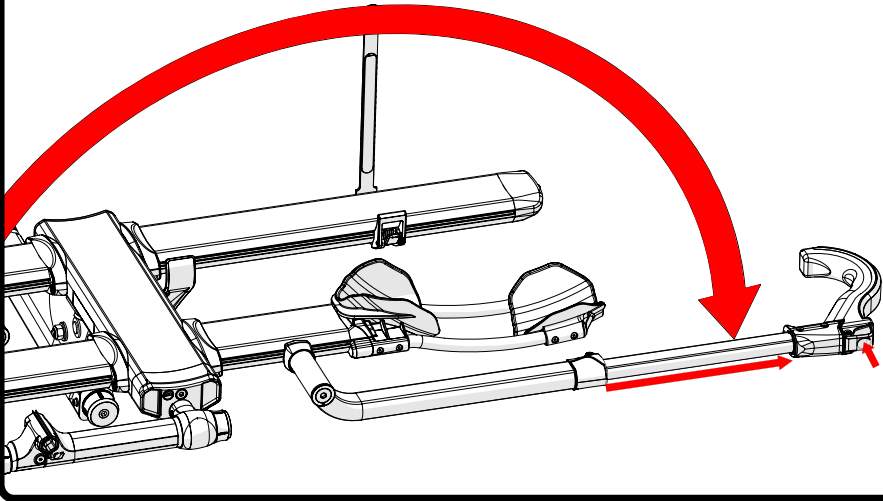

STEP 2. Set the bicycle on the rack and place the hook as close to the bicycle's front fork as possible, then ratchet the hook down onto the tire.

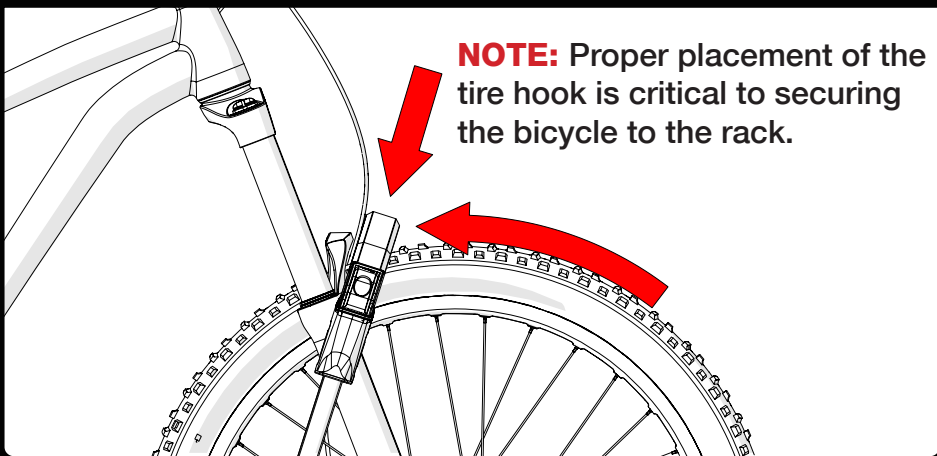

NOTE: Proper placement of the tire hook is critical to securing the bicycle to the rack.

NOTE: To adjust for bicycle fit issues loosen the front cradle bolt with an 8mm allen wrench (Do not fully remove the bolt). Once loose, move the cradle to one of three positions; up, center, or down. Tighten the bolt to secure the cradle in position. Failure to re-tighten bolt can lead to loss of bike.

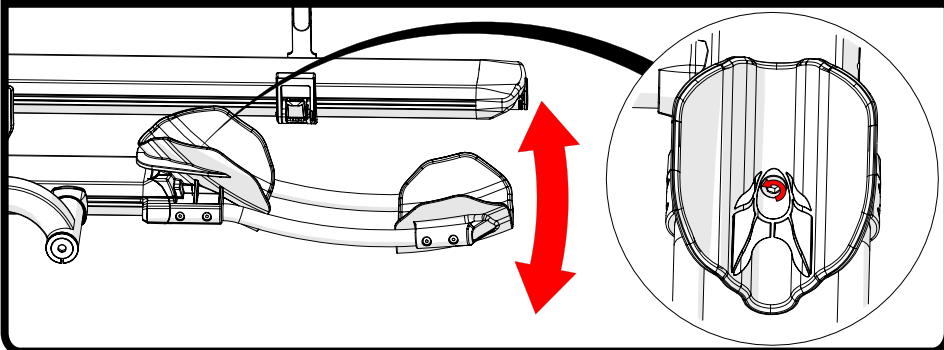

STEP 3. Feed the rear tire strap through the rear tire and behind the tire retention tab, then pull through the ratchet pawl until the rear tire is secure.

NOTE: Failure to properly feed and tighten the strap can lead to loss of bike.

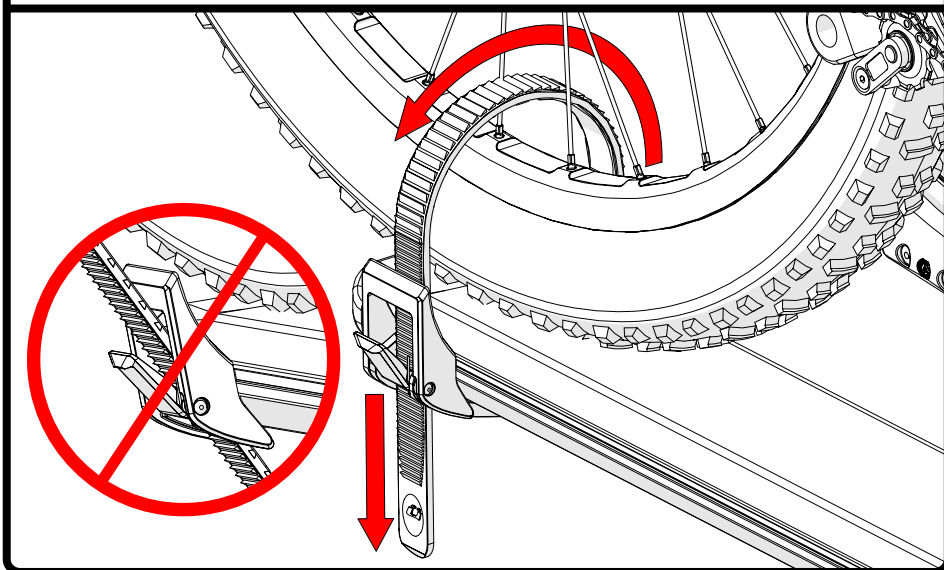

STEP 4. Pull the lock and cable completely out from the rear tire tray.

NOTE: When re-inserting the lock cable into the rack there should be a positive engage between the cable and the magnet in the back of the tray.

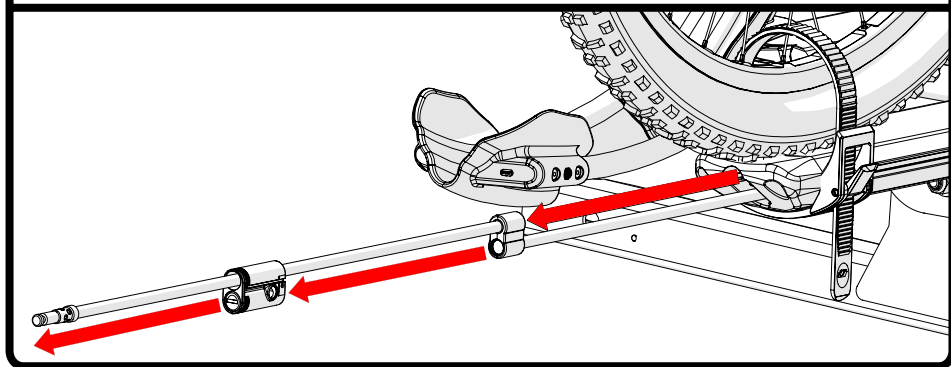

STEP 5. Loop the cable through the rear triangle and insert the lock tip into the lock found on the cable.

NOTE: Each lock cable is designed to lock a single bicycle. Do not lock the two cables together.

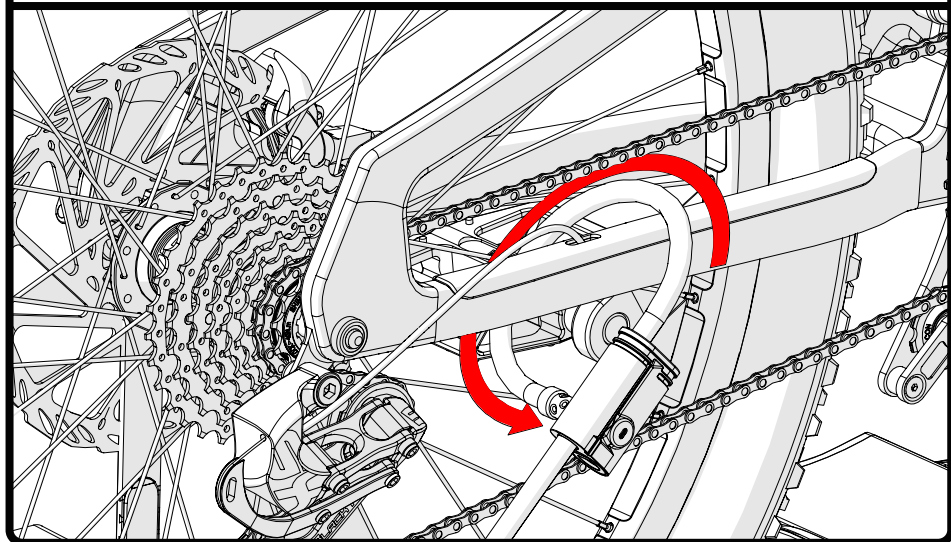

STEP 6. When adjusting the pivot position always support the end of the rack before engaging the pivot lever. This will assist with the release of the pivot lever and prevent the rack from falling.

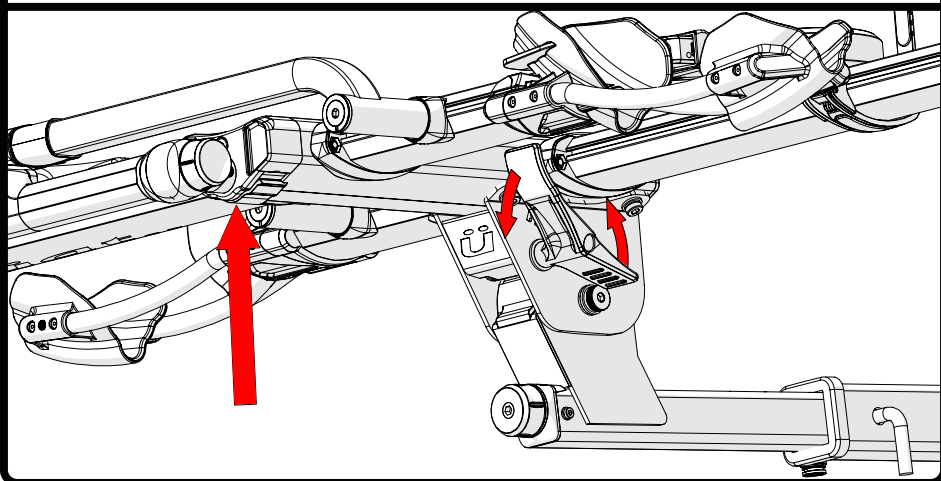

NOTE: The rack can tilt down for access to the rear hatch of the vehicle. Use caution when opening the rear hatch as this may not clear all hatches.

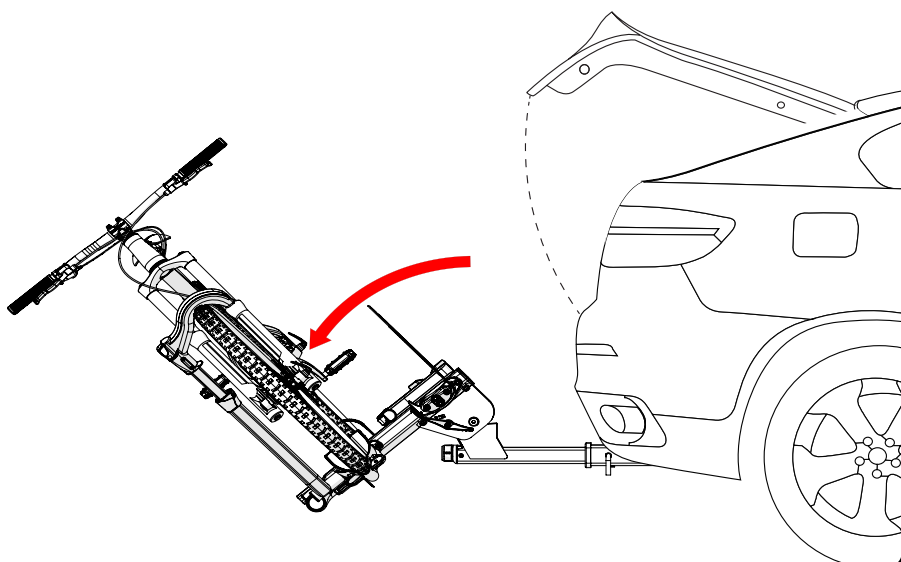

Operating the Trail Doc™:

STEP 1. Open the Trail Doc™ clamp by rotating the knob counterclockwise until the clamp springs open.

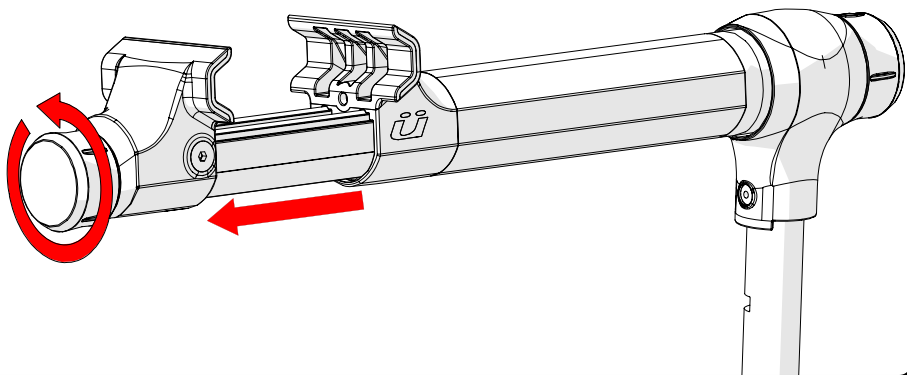

STEP 2. While holding the bicycle in place rotate the knob 1/4 of a turn clockwise, to engage the ratcheting mechanism, and close the clamp. Once the clamp is closed continue to rotate the knob clockwise until the bicycle is secured.

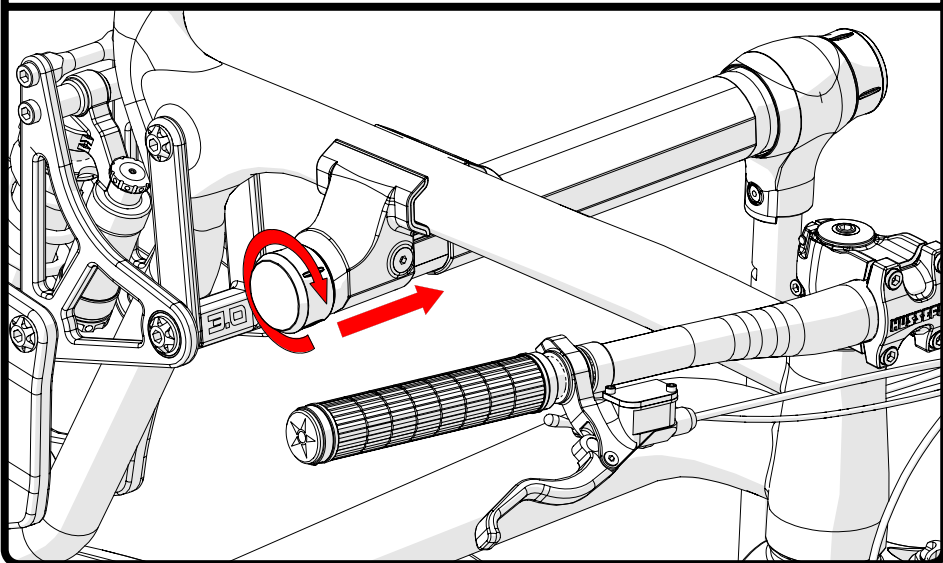

Additional Notes:

NOTE: When loading bicycles with 20"-24" front tires an adapter must be used.

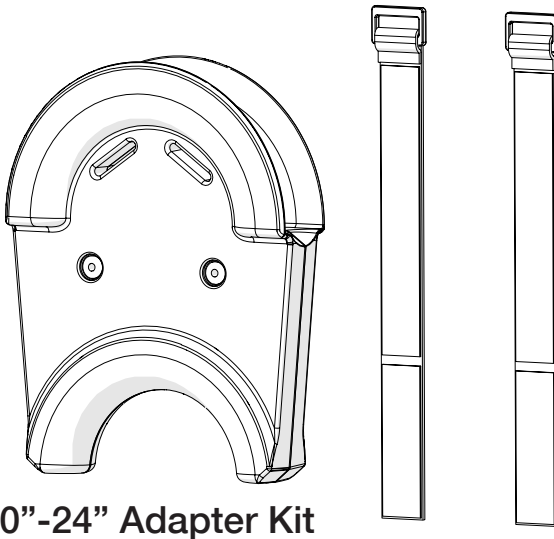

Tips and Tricks.

- Periodically check all nuts and bolts for proper tightness, not doing so can lead to premature wear or rack failure.
- Lubricate the lock mechanisms using a light oil. Keep the cover on the hitch pin lock at all times.
- The 8mm allen wrench can be stored in the rear end cap for easy access.
- The 8mm allen wrench can be used to tighten and loosen the cam system.
- Keeping your rack clean will help prevent corrosion and keep the rack working correctly for years.
- The pivot handle is also designed to be used as foot pedal when lowering the trays.
- Make sure the bicycles' tires are properly inflated and free of leaks. Bicycles can become loose if a tire deflates while in the rack.

Kuat Rack Warnings

NV™ 2.0

Number Of Bikes

| |
|---|
| 2 |
|---|

Weight Per Bike

| |
|---------|
| 60 lb |
| 27.2 kg |

Max Wheelbase

| |
|---------|
| 48 in |
| 1219 mm |

Max Tire Width

| |
|--------|
| 4.8 in |
| 121 mm |

Kuat No Worries Warranty

Our “No Worries Warranty” has you covered like the poncho in your backpack or the winch on your bumper, there when you need it. The goal? To ensure your Kuat product performs as intended, over time, every time, for life.

WARNINGS

- Follow instructions for proper assembly, mounting and loading procedures.
- Check tightness of all bolts and screws periodically.
- Make sure the rack and your vehicle receiver are in good working condition before each use.
- If bicycle tire exceeds the width of 3in you must use Phat Tire kit.
DO NOT EXCEED MAX TIRE WIDTH OF 4.8in
- Do not use rack off-road.
- Do not use hitch extenders with this product.
- Do not use this product on a recreational vehicle or trailer.
- Do not use rain or wind-covers or tarps with this product.
- Place the front tire clamp next to the front fork.
- Do not take through automatic carwash.
- Do not use front tire bicycle fenders with this product.