



INSTALLATION & START-UP GUIDE
Gen2 Power Steering Gear



KSE's Gen2 power steering gear is an inboard mount design with an integral power steering fluid reservoir. The inboard mount design and method of mounting controls rotary movement of the steering gear and eliminates chassis flex forces through the steering gear. Two mounting tabs on the chassis are required. One tab is located on the motor plate top chassis tube and the other on the top steering gear mounting tube.

These mounting tabs are standard on most chassis or can be ordered on all new chassis. The integral "live-tube" power steering fluid reservoir is designed to operate cooler than an external reservoir and minimize fluid turbulence and aeration.

GEN2 STEERING GEAR MOUNTING INSTRUCTIONS

STEP 1 Remove snap ring and inboard mounting retaining cap.

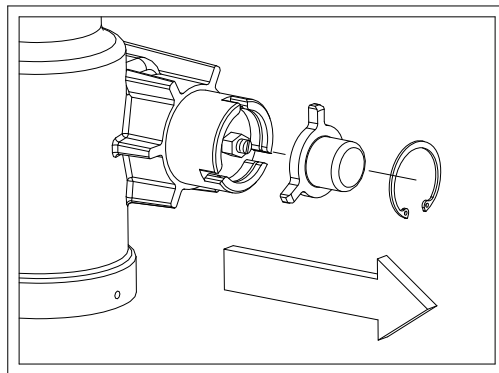

STEP 2 Loosen or remove output tube mounting clamp on chassis.

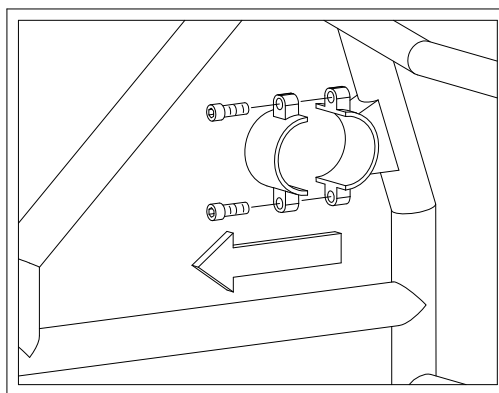

STEP 3

Install Gen2 steering gear by sliding output tube through chassis mount far enough to allow clearance for installation of inboard mounting bracket.

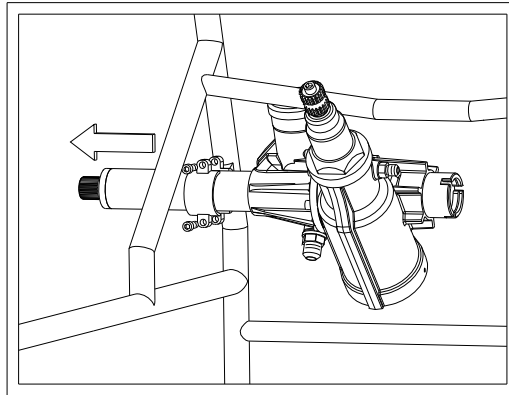

STEP 4

Install inboard mounting bracket P/N KSC1070 or equivalent, on chassis mounting tabs. Depending on tab locations, either side is acceptable.

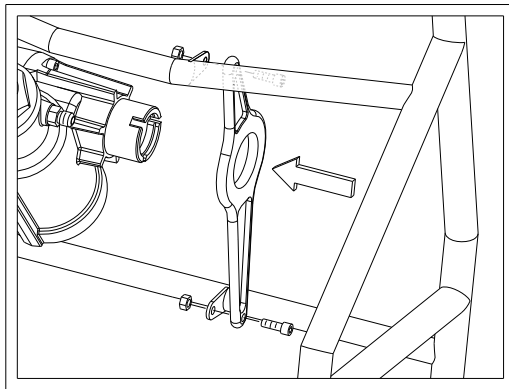

STEP 5

Slide Gen2 steering gear into inboard mounting bracket.

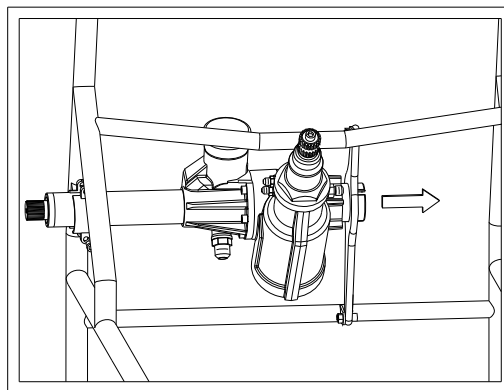

STEP 6

Install top mounting bracket over input tube of steering gear and bolt to upper steering mounting tube of chassis. For strength and safety, we recommend the two bolt style upper mounting bracket.

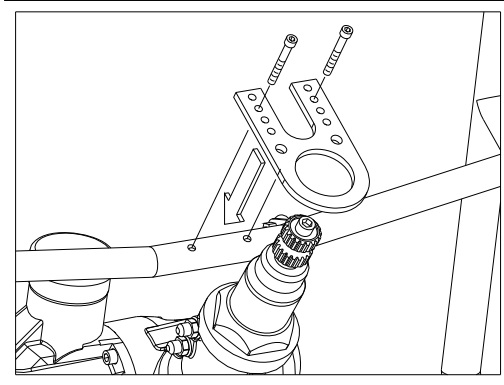

STEP 7

Install inboard mount retaining cap and snap ring.

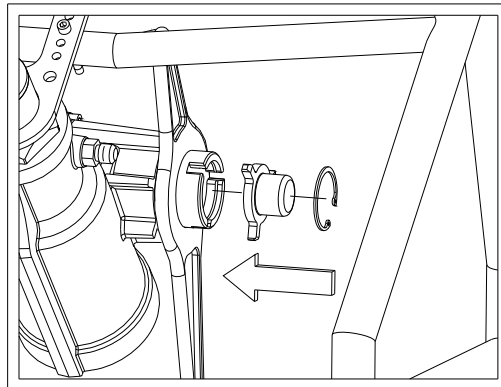

STEP 8

Tighten output tube mounting bracket. It is not recommended to float this mounting point with the inboard mounting system.

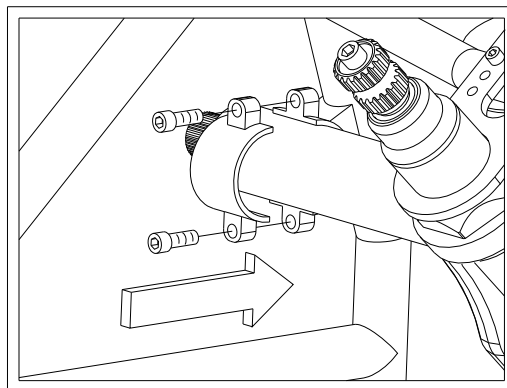

POWER STEERING GEAR PLUMBING

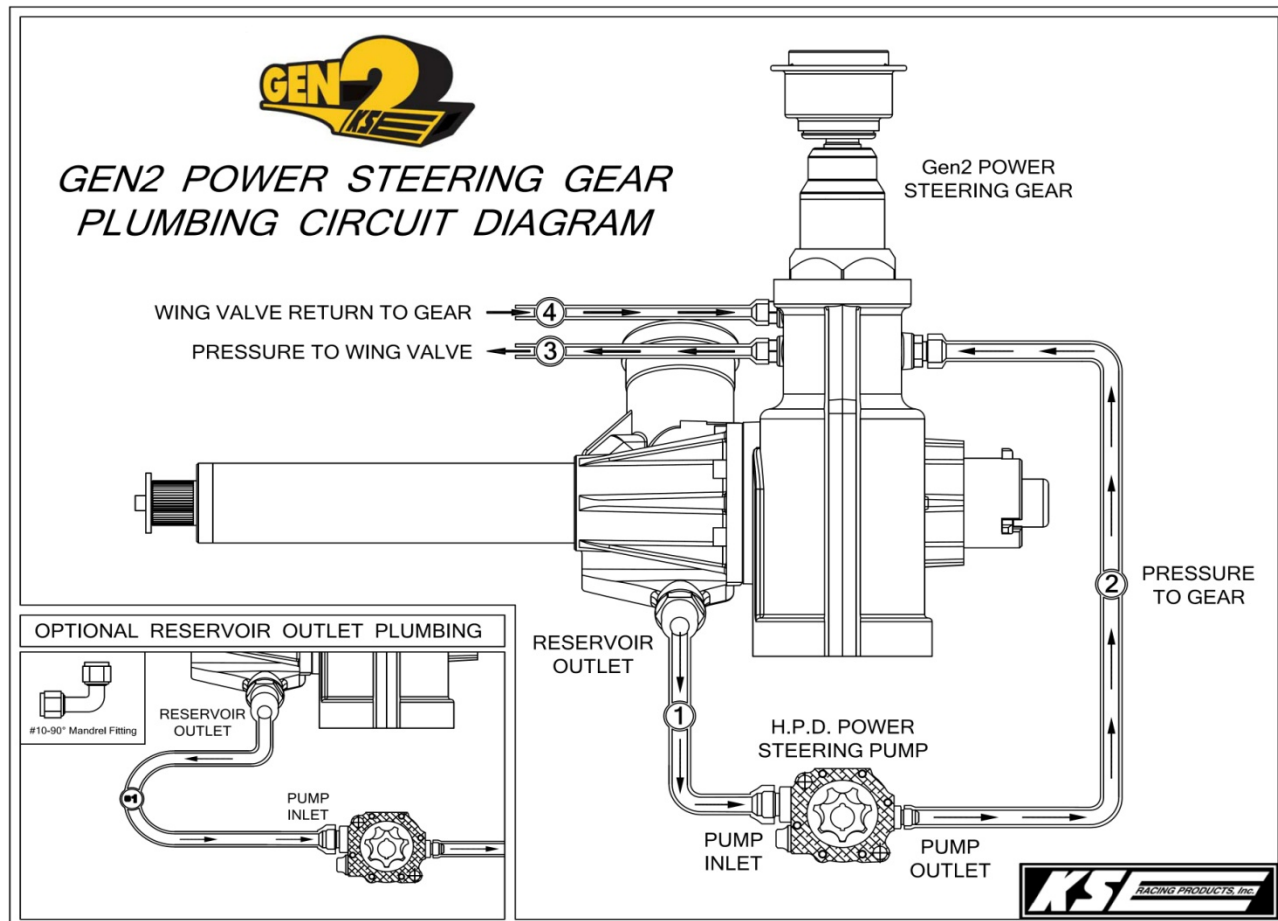

IMPORTANT: All hoses and fittings must be clean and free of all contamination. It is highly recommended that these components be flushed with clean solvent or hot soap and water and blown dry before assembly. When installing hoses, take care to assure that they will not be exposed to being pinched, cut or rubbed that would cause hose damage or failure, which could cause poor power steering performance or failure.

STEP 1 Pump inlet line (Reservoir to Pump - Line #1) must be a minimum #10 (3/4" ID) line. This hose must be vacuum rated to 20 IN HG in order to mitigate hose collapse. Notably, the short distance between the reservoir outlet and the pump inlet may require that the hose turn to the left out of the reservoir using a #10 - 90° mandrel fitting and loop back right straight into pump inlet as seen in attached figure. We recommend the use of KSE P/S Pump P/N KSC1068-002 be mounted with the inlet to the left side.

STEP 2 Pressure line (Pump to Steering Gear Pressure Port - Line #2) should be a minimum #6 (3/8" ID) line. This hose should be rated 2000 PSI working pressure 6000 PSI burst rating. Push-lock style hose fittings are not acceptable on a high pressure line.



HYDRAULIC WING SLIDER

Wing slider hoses (Lines 3 & 4) should be a minimum #4 (1/4" ID) line. The pressure line (Line #3) to the wing slider valve should be 2000 PSI working 6000 PSI burst rated. The return hose (Line #4) can be 100 PSI working 300 PSI burst rated.

STEP 1 Remove socket head o-ring plugs from auxiliary ports of Gen2 steering gear. Install two #3 ORB - #4 37° fittings (P/N KSM6002).

STEP 2 Install pressure line (Line #3) to pressure port of wing slider valve and return line (Line #4) to return port of wing slider valve.

START-UP AND AIR PURGING

CAUTION: Running the P/S pump without fluid will cause damage to the pump.

RECOMMENDED AIR PURGING METHOD

Unbolt P/S pump and pull it back far enough to disengage shaft from the drive spud. Fill P/S reservoir with KSE Elixer P/S fluid (P/N KSM1086). Using a suitable drill with a 3/8" hex socket, spin the P/S pump shaft from the back (i.e. fuel pump end) at a minimum of 500 RPM. **IMPORTANT:** Check for proper shaft rotation. Monitor fluid level and add as required. Disconnect drag link from pitman arm. With pump running turn steering wheel full left until it stops and full right until it stops, do this a minimum of three cycles. Cycle wing valve several times during procedure. Stop pump and let stand 30 minutes. Check P/S fluid level and add as required. Start pump and repeat above procedure. **NOTE:** If the above procedure is not used, maximum P/S performance will not be achieved until 2 or 3 racing cycles.

CENTERING STEERING GEAR

Setup car at desired ride height with the front wheels in the straight ahead position and pitman arm disconnected from the steering gear output shaft. Turn the steering wheel slowly to the left until it stops. Turn the steering wheel slowly to the right while counting turns until it stops. Turn the steering wheel left 1/2 the amount previously counted. Connect the pitman arm to the steering gear output shaft. The pitman arm should be 90 degrees (perpendicular) to the drag link or slightly forward.

INSTALLATION OF INBOARD MOUNTING TABS

For self installation of inboard mounting tabs to the chassis, one consideration to be made in determining appropriate tab location is whether the inboard mounting bracket is to be to the **right or left** (outside or inside) of the tabs. Notably, either side is acceptable; however, tab location on the chassis will change accordingly. For a frame centered gear, these tab locations from the gear centerline / frame centerline for either option are as follows:

Location for bracket installation to the **right** of the tabs: **3" ± 3/32"** from centerline.

Location for bracket installation to the **left** of the tabs: **3-11/16" ± 3/32"** from centerline.