



Manufacturers and Designers of Performance Power Steering Systems and Components

ALUMINUM PUMP INSTRUCTIONS

IMPORTANT! PLEASE READ THESE SHEETS BEFORE INSTALLATION

You must first calculate pump rpm prior to installing this pump. Divide your crank pulley diameter by the power steering pump pulley diameter and multiply by maximum engine rpm. (Example: $4.5'' \text{ cp} \div 6'' \text{ psp} = 0.75 \times 7,200 = 5,400 \text{ rpm pump speed.}$) **Maximum recommended aluminum pump speed is 9,000 rpm.** The higher the pump rpm the more horsepower the steering pump will consume. The steering pump will give maximum assist by 1,500 rpms, so turning it faster will only consume more horsepower. You must keep in mind that the pit speed of the pump must be in the 1,000-1,500 rpm range. Torque on the pump pulley nut is 46 ft lbs.

Installation Instructions:

1) Mount your pump according to the instructions supplied with your mounting bracket kit. If needed, use flat washers or machine custom spacers to align the steering pump pulley with your drive system. Make sure the spacing is the same on all mounting points or you may experience belt problems.

2) Mount the reservoir tank so the bottom of the fluid level, in the tank, will be at least two inches above the top of the pump. This will insure that you won't have a supply problem feeding the pump. All pumps require a gravity feed on the fluid to prime it. The suction will go up as the rpm's increase.

3) Using only high pressure power steering hose (Aeroquip Blue P/S Hose or equivalent) connect (-10 hose) **A** on the tank to **A** on the pump. Then connect the (-6) pressure line **B** on the pump to the servo or the largest hole on the stock steering box. O-ring or inverted flare stock steering box to -6 adapters are sold separately. Connect the return line on the servo, or small hole on a stock steering box, to **C** on the tank. **Please read "Power Steering Hose Tech" for more information regarding the proper hose requirements for a power steering system.**

4) Fill the tank (KRC Power Steering Fluid is highly recommended) to a point halfway between the -6 return fitting and the top of the tank. Then rotate the pump several times to prime it before starting the engine. (Tip: Using an electric drill will help prime the system at a low speed). Raise the front wheels off of the ground. Move the tire left and right several times. You should see air bubbles working there way out of the tank. When there are not more air bubbles, the system should be bleed. After starting the engine and getting the fluid up to temperature, shut the engine off and twist the cap off slightly to allow any additional air to escape. Reinstall cap. If you had power steering on your system previously and capped the lines, when you reinstall the pump you may need to loosen the -6 and -10 hose ends to allow any possible air pockets to escape (with the engine running). Then re-tighten the lines.

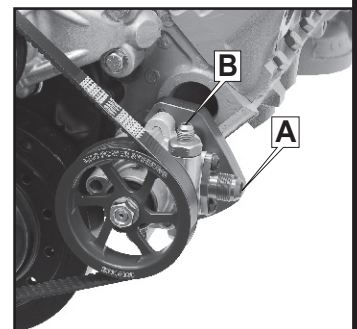
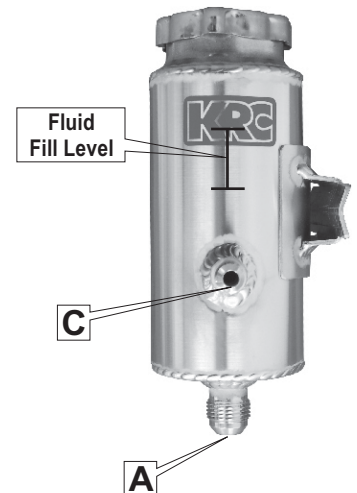



Manufacturers and Designers of Performance Power Steering Systems and Components

ALUMINUM PUMP INSTRUCTIONS

KRC'S EXCLUSIVE CHANGEABLE FLOW VALVE TECHNOLOGY

KRC offers the only pump with changeable flow control fittings. KRC pumps are shipped with a standard flow control fitting that will give you excellent feel and assist in 90% of all applications. The standard -6 flow fitting has no identification mark on the hex. All optional flow fittings have an identifying mark stamped on the hex, and they will allow you to change the feel in your steering (see chart to right). The more flow your steering system receives the easier it will be to turn the wheels. If you increase the flow too much, the road feel in the steering will go away at higher speeds. Higher flow fittings are required when using steering quickeners or 3.4 inch per revolution, or faster, rack & pinions on short tracks with tight turns. Lower flow fittings are required to put feel and stability back in the steering on tracks with long straightaways. Cars on super speedways can use number 4 through 7 fittings, while a 1/4 mile track open wheel modifieds with 2-to-1 steering quickeners could try a B through E fitting. When selecting a flow control valve for a race track only car, the driver should use the valve that feels best at race speeds. On street driven race cars, you must consider finding a happy medium between the ease of parking and highway speed stability. Optional flow control valves are available individually or in sets of 4 from KRC or your local dealer. In high vibration applications you may want to use a steel flow fitting. To order a steel flow fitting change the 3 in the part number to a 4.

Aluminum Fitting Part Number	Aluminum Pump Flow	ID Mark
KRC 25300 407	SET OF 4	--
KRC 25300 912	SET OF 4	--
KRC 25304 000	1.05 GPM	4
KRC 25305 000	1.32 GPM	5
KRC 25306 000	1.58 GPM	6
KRC 25307 000	1.84 GPM	7
KRC 25308 000	2.11 GPM	NONE
KRC 25309 000	2.37 GPM	B
KRC 25310 000	2.64 GPM	C
KRC 25311 000	2.90 GPM	D
KRC 25312 000	3.17 GPM	E

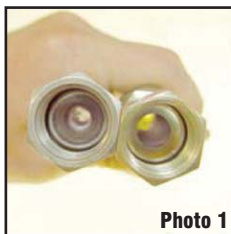

Photo 1

Power steering pumps require a hose with a vacuum rating of 28 INCHES/HG on the inlet side, and a minimum 1/2" inside diameter. This is required to keep the hose from collapsing at higher RPMs. As seen in Photo 1 to the left, common hydraulic hose may have a 10 fitting on them, but the inside diameter is smaller than 6 (.265"). This will damage the pump because there is no way for the pump to intake enough fluid to meet its requirement through such a small hole.



Photo 2

Push lock hose may be the proper inside diameter, but the vacuum rating is only 18 INCHES/MG. As the fluid warms up, this rating actually goes down. Push lock hose will suck shut anywhere there is a bend in it, starving the pump of fluid and can cause severe damage to the internals of the pump. See Photo 2.

The 6 pressure hose, leaving the pump, must have an operating pressure of 2,250 psi. and an inside diameter of .31". Common hydraulic hose may have the proper operating range, but their inside diameter is slightly smaller. See Photo 3. The smaller diameter can restrict the flow to the steering gear. This can cause problems in your steering, such as tight spots in the turns and increased driver effort.

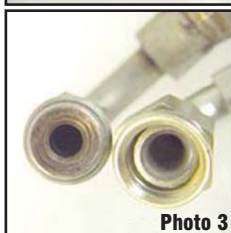

Photo 3

Also make sure the -10 feed line from the reservoir tank, remote tanks only, has a 1/2" inside diameter. Some companies have been importing tanks to the U.S. that have a 3/8" inside diameter. This will restrict flow to the pump and will damage the pump within a few races.

KRC only recommends Aeroquip AQP High Pressure power steering hose with steel AN fittings.

Power Steering Hose Tech



Manufacturers and Designers of Performance Power Steering Systems and Components

ALUMINUM PUMP INSTRUCTIONS

Tips To Extend the Life of Your New Pump:

- 1) Never start your engine without fluid in the reservoir tank. One minute without fluid can permanently damage the pump.
- 2) Route all hoses away from headers to keep from adding heat to the system and burning the fluid.
- 3) We highly recommend a mineral based power steering fluid or equivalent. In our test, it runs cooler than synthetic based fluids. **For best results use KRC Power Steering fluid.**
- 4) When assembling new hoses, clean them with a rifle bore brush, then flush them out with hot water and air dry before use. Most problems with power steering systems are due to contamination from new hoses, or other steering components, which in turn damages the pump. Always place caps on pumps, steering gears and hoses when system is open to the air.
- 5) Install any filters or coolers on the return side if they are needed.

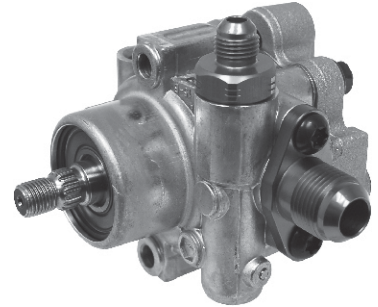

Common Questions and Answers:

- 1) **Steering feel is too heavy in the turns:** Change optional flow fitting to a higher letter.
- 2) **Steering feel is too light in the turns:** Change optional flow fitting to a lower number.
- 3) **Pump stopped working after only a few laps:** The most common problem on installation is forgetting to clean out the hoses and steering box when installing a new pump. The pump may have to be returned to the factory for cleaning to remove all trash.
- 4) **Assist fades the longer you race:** Overheating the fluid is the problem. Check the fluid temperature immediately after the race. The fluid should not be over 250 degrees. If it is over 250 degrees the heat is coming from an outside source or maximum rpm of pump has been exceeded. Use only high temperature, anti-foaming power steering fluid. Check for lines or tank that may be near headers. You can add a cooler in the return line if needed, that may cure the problem.

Checking for Suspension Bind:

It is critical to check for any suspension bind in the steering system. Place the car on jack stands and remove the springs from the front of the car. Move the suspension up one inch past the normal suspension travel, then move the steering wheel left and right (with the suspension up). Repeat the same process, but move the suspension down one inch past the normal suspension travel. Check for any binding in the suspension and steering. This will insure you have proper clearance of all steering components. Dirt cars may require the use of a limiting strap on the left front wheel. When the wheel lifts in the corner and is dangling, the steering system may be placed in a bind. Ball joints also have a limit to the travel they can move. If the ball joints extend past their travel limits, it will lock down the steering. Any bind in the suspension will increase the amount of pressure inside your steering system. It could cause the pump to go into pressure relief. The driver will feel a loss of power steering when this occurs.

Flow Valve and Pressure Relief Valve Installation:

Install spring first, then pressure relief valve, the last the flow valve. Torque flow valve to 46 ft lbs. This installation process is the same for both KRC aluminum and cast iron power steering pumps.

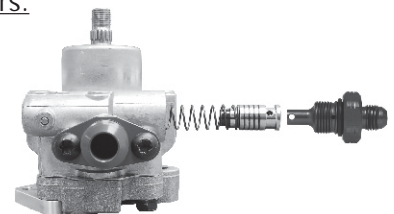



Manufacturers and Designers of Performance Power Steering Systems and Components

ALUMINUM PUMP INSTRUCTIONS

IMPORTANT! PLEASE READ THESE SHEETS BEFORE INSTALLATION

You must first calculate pump rpm prior to installing this pump. Divide your crank pulley diameter by the power steering pump pulley diameter and multiply by maximum engine rpm. (Example: $4.5'' \text{ cp} \div 6'' \text{ psp} = 0.75 \times 7,200 = 5,400 \text{ rpm pump speed.}$) **Maximum recommended aluminum pump speed is 9,000 rpm.** The higher the pump rpm the more horsepower the steering pump will consume. The steering pump will give maximum assist by 1,500 rpms, so turning it faster will only consume more horsepower. You must keep in mind that the pit speed of the pump must be in the 1,000-1,500 rpm range. Torque on the pump pulley nut is 46 ft lbs.

Installation Instructions:

- Mount your pump according to the instructions supplied with your mounting bracket kit. If needed, use flat washers or machine custom spacers to align the steering pump pulley with your drive system. Make sure the spacing is the same on all mounting points or you may experience belt problems.
- Using only high pressure power steering hose (Aeroquip Blue P/S Hose or equivalent). Connect the (6) pressure line **A**, on the pump, to the servo or the largest hole on the stock steering box. O ring or inverted flare stock steering box to 6 adapters are sold separately. Connect the return line on the servo, or small hole on a stock steering box, to **B** on the tank.
- Fill the tank (KRC Power Steering Fluid is highly recommended) to a point halfway between the 6 return fitting and the top of the tank. Then rotate the pump several times to prime it before starting the engine. (Tip: Using an electric drill will help prime the system at a low speed). Raise the front wheels off of the ground. Move the tire left and right several times. You should see air bubbles working there way out of the tank. When there are not more air bubbles, the system should be bled. After starting the engine and getting the fluid up to temperature, shut the engine off and twist the cap off slightly to allow any additional air to escape. Reinstall cap. If you had power steering on your system previously and capped the lines, when you reinstall the pump you may need to loosen the 6 and 10 hose ends to allow any possible air pockets to escape (with the engine running). Then re tighten the lines. **With the car at idle make sure the fluid level is at the weld line. If the top of the tank is leaned counter-clockwise (facing the pulley) make sure the fluid level covers the -6 return tube inside the tank, while the engine is running. If not aeration of the fluid may occur.**

Bolt-On Tank Notes:

- Bolt on reservoirs will always increase the fluid temperature in the system. If temperature exceeds 250° you must add a cooler somewhere in the return line.
- Now that there is no inlet line that can potentially suck shut, you have eliminated one of the most common reasons for pump failure.
- On high volume pumps, back pressure may occur in the steering system. We offer tank part number KRC 9131800 that has a 8 return fitting, allowing you to use a 8 return lines to alleviate the back pressure problem.
- DO NOT use a vented cap with this tank. Foaming of the fluid will occur.
- We highly recommend a mineral based power steering fluid or equivalent. In our test, it runs cooler than synthetic based fluids. **For best results use KRC Power Steering fluid.**

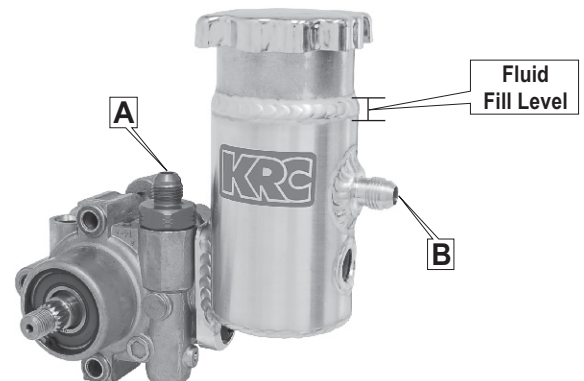



Manufacturers and Designers of Performance Power Steering Systems and Components

CAST IRON PUMP INSTRUCTIONS

IMPORTANT! PLEASE READ THESE SHEETS BEFORE INSTALLATION

You must first calculate pump rpm prior to installing this pump. Divide your crank pulley diameter by the power steering pump pulley diameter and multiply by maximum engine rpm. (Example: $4.5'' \text{ cp} \div 6'' \text{ psp} = 0.75 \times 7,200 = 5,400 \text{ rpm pump speed.}$)

Maximum recommended cast iron pump speed is 5,500 rpm. The higher the pump rpm the more horsepower the steering pump will consume. Our aluminum pumps are rated at 9,000 rpm and may be a better choice for your application. Torque on the pump pulley nut is 46 ft lbs.

This unit will replace GM Saginaw style power steering pumps in every dimension, except the pressure out fitting will point down instead of up. Each pump is packaged with 2 spacers, .50"OD x 2.212" long, that will fill the space between the pump ears and the mounting bracket. Use bolts furnished with your mounting bracket kit to attach the pump as shown in drawing below. Depending on the diameter of the pulley, you may need to install pump mounting bolts before you attach your pulley.

Installation Instructions:

1) Mount your pump according to the instructions supplied with the mounting your bracket kit. If needed, use flat washers or machine custom spacers to align the steering pump with your drive system. Make sure the spacing is the same on all mounting points or you may experience belt problems.

2) Mount the reservoir tank so the bottom of the fluid level, in the tank, will be at least two inches above the top of the pump. This will insure that you won't have a supply problem feeding the pump. All pumps require a gravity feed on the fluid to prime it. The suction will go up as the rpm's increase.

3) Using only high pressure power steering hose (Aeroquip Blue P/S Hose or equivalent) connect (-10 hose) **A** on the tank to **A** on the pump. Then connect the (-6) pressure line **B** on the pump to the servo or the largest hole on the stock steering box. O-ring or inverted flare stock steering box to -6 adapters are sold separately. Connect the return line on the servo, or small hole on a stock steering box, to **C** on the tank. **Please read "Power Steering Hose Tech" for more information regarding the proper hose requirements for a power steering system.**

4) Fill the tank (KRC Power Steering Fluid is highly recommended) to a point halfway between the -6 return fitting and the top of the tank. Then rotate the pump several times to prime it before starting the engine. (Tip: Using an electric drill will help prime the system at a low speed). Raise the front wheels off of the ground. Move the tire left and right several times. You should see air bubbles working there way out of the tank. When there are not more air bubbles, the system should be bleed. After starting the engine and getting the fluid up to temperature, shut the engine off and twist the cap off slightly to allow any additional air to escape. Reinstall cap. If you had power steering on your system previously and capped the lines, when you reinstall the pump you may need to loosen the -6 and -10 hose ends to allow any possible air pockets to escape (with the engine running). Then re-tighten the lines.

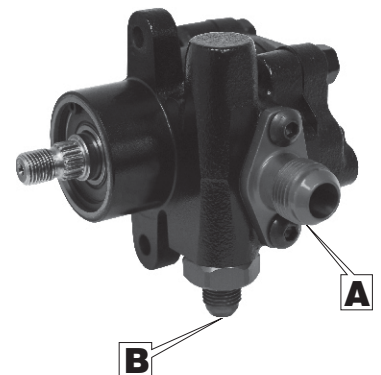
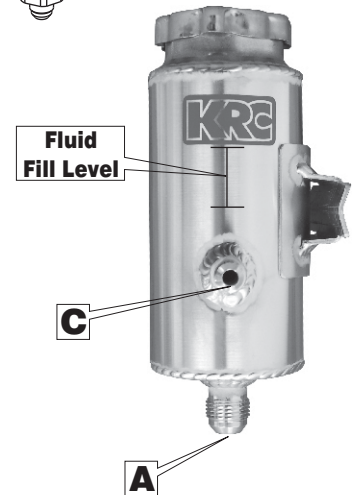
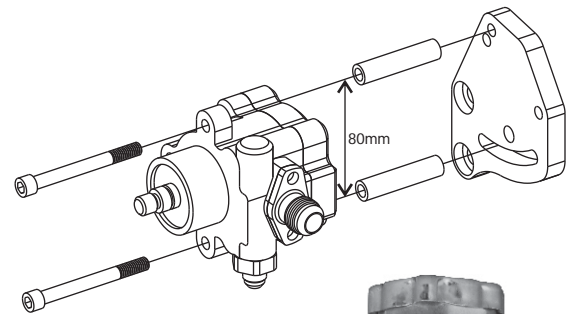



Manufacturers and Designers of Performance Power Steering Systems and Components

CAST IRON PUMP INSTRUCTIONS

IMPORTANT! PLEASE READ THESE SHEETS BEFORE INSTALLATION

You must first calculate pump rpm prior to installing this pump. Divide your crank pulley diameter by the power steering pump pulley diameter and multiply by maximum engine rpm. (Example: 4.5" cp ÷ 6" psp = 0.75 x 7,200 = 5,400 rpm pump speed.) **Maximum recommended cast iron pump speed is 5,500 rpm.** The higher the pump rpm the more horsepower the steering pump will consume. Our aluminum pumps are rated at 9,000 rpm and may be a better choice for your application. Torque on the pump pulley nut is 46 ft lbs.

This unit will replace GM Saginaw style power steering pumps in every dimension, except the pressure out fitting will point down instead of up. Each pump is packaged with 2 spacers, .50"OD x 2.212" long, that will fill the space between the pump ears and the mounting bracket. Use bolts furnished with your mounting bracket kit to attach the pump as shown in drawing below. Depending on the diameter of the pulley, you may need to install pump mounting bolts before you attach your pulley.

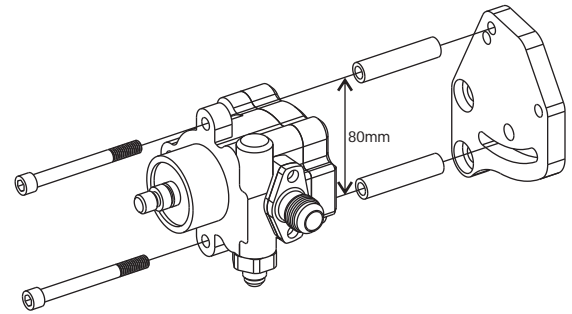

Installation Instructions:

1) Mount your pump according to the instructions supplied with your mounting bracket kit. If needed, use flat washers or machine custom spacers to align the steering pump pulley with your drive system. Make sure the spacing is the same on all mounting points or you may experience belt problems.

2) Using only high pressure power steering hose (Aeroquip Blue P/S Hose or equivalent). Connect the (-6) pressure line **A**, on the pump, to the servo or the largest hole on the stock steering box. O-ring or inverted flare stock steering box to -6 adapters are sold separately. Connect the return line on the servo, or small hole on a stock steering box, to **B** on the tank.

3) Fill the tank (KRC Power Steering Fluid is highly recommended) to a point halfway between the -6 return fitting and the top of the tank. Then rotate the pump several times to prime it before starting the engine. (Tip: Using an electric drill will help prime the system at a low speed). Raise the front wheels off of the ground. Move the tire left and right several times. You should see air bubbles working there way out of the tank. When there are not more air bubbles, the system should be bled. After starting the engine and getting the fluid up to temperature, shut the engine off and twist the cap off slightly to allow any additional air to escape. Reinstall cap. If you had power steering on your system previously and capped the lines, when you reinstall the pump you may need to loosen the -6 and -10 hose ends to allow any possible air pockets to escape (with the engine running). Then re-tighten the lines. **With the car at idle make sure the fluid level is at the weld line.**

If the top of the tank is leaned counter-clockwise (facing the pulley) make sure the fluid level covers the -6 return tube inside the tank, while the engine is running. If not aeration of the fluid may occur.

Bolt-On Tank Notes:

- Bolt-on reservoirs will always increase the fluid temperature in the system. If temperature exceeds 250° you must add a cooler somewhere in the return line.
- Now that there is no inlet line that can potentially suck shut, you have eliminated one of the most common reasons for pump failure.
- On high volume pumps, back pressure may occur in the steering system. We offer tank part number KRC 9131800 that has a -8 return fitting, allowing you to use a -8 return lines to alleviate the back pressure problem.
- DO NOT use a vented cap with this tank. Foaming of the fluid will occur.
- We highly recommend a mineral based power steering fluid or equivalent. In our test, it runs cooler than synthetic based fluids. **For best results use KRC Power Steering fluid.**

