



Belt Chart

Belt Lengths for KRC Alternator Brackets:

Chevrolet (Denso and Delco): 28.0" Belt with 3.5" Pulley and 26.0" Belt with 2.5" Pulley

Ford (Denso): 24.5" Belt with 3.5" Pulley and 24.0" Belt with 2.5" Pulley

Dodge (Denso) 26.7" Belt with 3.5" Pulley and 25.0" Belt with 2.5" Pulley

Chevrolet SB Pumps with 4.2" Serpentine Pump Pulley

Pulley Size	Pump Mount	Pulley Reduction	Cast Iron 1st Design Belt #	Belt Length	Pro Series Aluminum Belt #	Belt Length	Bolt Pattern
4.0" W/P 2.5" Crank	Head	37.50%	GDY 4060370	37"	GDY 4060374	37.4"	A
4.0" 3.0"	Head	25.00%	GDY 4060374	37.5"	GDY 4060380	38"	A
4.0" 3.2"	Head	20.00%	GDY 4060374	37.5"	GDY 4060390	39"	A
4.0" 3.5"	Head	12.50%	GDY 4060380	38"	GDY 4060374	37.4"	B
4.0" 4.0"	Head	0.00%	GDY 4060385	38.5"	GDY 4060380	38"	B
4.0" 2.5"	Block	37.50%	GDY 4060320	32"	GDY 4060330	33"	A
4.0" 3.0"	Block	25.00%	GDY 4060325	32.5"	GDY 4060330	33"	A
4.0" 3.2"	Block	20.00%	GDY 4060325	32.5"	GDY 4060335	33.5"	A
4.0" 3.5"	Block	12.50%	GDY 4060330	33"	GDY 4060340	34.0"	A
4.0" 4.0"	Block	0.00%	GDY 4060335	33.5"	GDY 4060345	34.5"	A

Bolt Pattern for Pro Series Pump

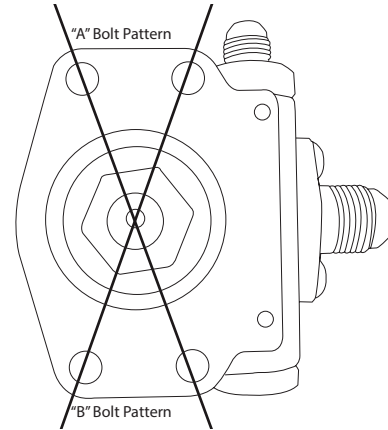

Chevrolet SB Pumps with 6.0" Serpentine Pump Pulley

Pulley Size	Pump Mount	Pulley Reduction	Cast Iron 1st Design Belt #	Belt Length	Pro Series Aluminum Belt #	Belt Length	Bolt Pattern
4.0" W/P 2.5" Crank	Head	37.50%	GDY 4060390	39"	GDY 4060380	38"	B
4.0" 3.0"	Head	25.00%	GDY 4060395	39.5"	GDY 4060385	38.5"	B
4.0" 3.2"	Head	20.00%	GDY 4060395	39.5"	GDY 4060390	39"	B
4.0" 3.5"	Head	12.50%	GDY 4060400	40"	GDY 4060395	39.5"	B
4.0" 4.0"	Head	0.00%	GDY 4060405	40.5"	GDY 4060400	40"	B
4.0" 2.5"	Block	37.50%	GDY 4060335	33.5"	GDY 4060345	34.5"	A
4.0" 3.0"	Block	25.00%	GDY 4060340	34"	GDY 4060350	35"	A
4.0" 3.2"	Block	20.00%	GDY 4060340	34"	GDY 4060355	35.5"	A
4.0" 3.5"	Block	12.50%	GDY 4060345	34.5"	GDY 4060355	35.5"	B
4.0" 4.0"	Block	0.00%	GDY 4060350	35"	GDY 4060360	36"	B

****For Chevrolet Tensioners, add 0.5" for Belt Length****

Chevrolet 350 Water Pump Only Drive Kit with Idler-Tensioner

Pulley Size	W/P	Crank	Belt Size	Part Number
4.0"	3.0"	25.2"	GDY 4060252	
4.0"	3.5"	26.0"	GDY 4060260	
4.0"	4.0"	26.5"	GDY 4060265	

302ci. Ford Pump Belt Chart

Pulley Size	Pump Mount	Pulley Reduction	Cast Iron 1st Design Belt #	Belt Length	Pro Series Aluminum Belt #	Belt Length	Bolt Pattern
4.2" Serpentine Pump Pulley							
4	2.5	Head	GDY 4060355	35.5"	GDY 4060350	35"	B
4	3.0	Head	GDY 4060360	36"	GDY 4060355	35.5"	B
4	3.2	Head	GDY 4060365	36.5"	GDY 4060355	35.5"	B
4	3.5	Head	GDY 4060365	36.5"	GDY 4060360	36"	B
4	4.0	Head	GDY 4060370	37"	GDY 4060365	36.5"	B

6.0" Serpentine Pump Pulley

4	2.5	Head	GDY 4060375	37.5"	GDY 4060365	36.5"	A
4	3.0	Head	GDY 4060380	38"	GDY 4060370	37"	A
4	3.2	Head	GDY 4060380	38"	GDY 4060374	37.4"	A
4	3.5	Head	GDY 4060385	38.5"	GDY 4060380	38"	A
4	4.0	Head	GDY 4060390	39"	GDY 4060380	38"	A

Ford 302 Water Pump Only Drive Kit with Idler-Tensioner

Pulley Size	W/P	Crank	Belt Size	Part Number
4.0"	3.0"	25.2"	GDY 4060252	
4.0"	3.5"	26.0"	GDY 4060260	
4.0"	4.0"	26.5"	GDY 4060265	

351ci. Ford Pump Belt Chart

Pulley Size	Pump Mount	Pulley Reduction	Cast Iron 1st Design Belt #	Belt Length	Pro Series Aluminum Belt #	Belt Length	Bolt Pattern
4.2" Serpentine Pump Pulley							
4	2.5	Head	GDY 4060360	36"	GDY 4060370	37"	A
4	3.0	Head	GDY 4060360	36"	GDY 4060374	37.4"	A
4	3.2	Head	GDY 4060365	36.5"	GDY 4060380	38"	A
4	3.5	Head	GDY 4060370	37"	GDY 4060380	38"	A
4	4.0	Head	GDY 4060374	37.4"	GDY 4060390	39"	A
6.0" Serpentine Pump Pulley							
4	2.5	Head	GDY 4060380	38"	GDY 4060374	37.4"	B
4	3.0	Head	GDY 4060385	38.5"	GDY 4060380	38"	B
4	3.2	Head	GDY 4060390	39"	GDY 4060385	38.5"	B
4	3.5	Head	GDY 4060390	39"	GDY 4060385	38.5"	B
4	4.0	Head	GDY 4060395	39.5"	GDY 4060390	39"	B

****3.5" water pump pulley, decrease the belt length by .5"*****

Ford 351 Water Pump Only Drive Kit with Idler-Tensioner

Pulley Size	W/P	Crank	Belt Size	Part Number
4.0"	3.0"	25.2"	GDY 4060252	
4.0"	3.5"	26.0"	GDY 4060260	
4.0"	4.0"	26.5"	GDY 4060265	

Chevrolet 350 Alternator Belt 3.5" Accessory Drive Pulley

Alt. Pulley Size	Belt Size	Part Number
2.5"	26.0"	GDY 4030260
3.5"	28.0"	GDY 4060280

Ford 302 Alternator Belt 3.5" Accessory Drive Pulley

Alt. Pulley Size	Belt Size	Part Number
2.5"	24.0"	GDY 4030240
3.5"	24.5"	GDY 4030245

Ford 351 Alternator Belt 3.5" Accessory Drive Pulley

Alt. Pulley Size	Belt Size	Part Number
2.5"	24.0"	GDY 4030240
3.5"	24.5"	GDY 4030245

Dodge 360 Crate Pump Belt Chart

Pulley Size	Pump Mount	Cast Iron 1st Design Belt #	Belt Length	Pro Series Aluminum Belt #	Belt Length	Bolt Pattern
4.2" Serpentine Pump Pulley						
4	2.5	Block	GDY 4060320	32"	GDY 4060330	33"
4	3.0	Block	GDY 4060325	32.5"	GDY 4060335	33.5"
4	3.2	Block	GDY 4060330	33"	GDY 4060335	33.5"
4	3.5	Block	GDY 4060330	33"	GDY 4060340	34"
4	4.0	Block	GDY 4060335	33.5"	GDY 4060345	34.5"
6.0" Serpentine Pump Pulley						
4	2.5	Block	GDY 4060335	33.5"	GDY 4060350	35"
4	3.0	Block	GDY 4060340	34"	GDY 4060355	35.5"
4	3.2	Block	GDY 4060345	34.5"	GDY 4060355	35.5"
4	3.5	Block	GDY 4060350	35"	GDY 4060360	36"
4	4.0	Block	GDY 4060355	35.5"	GDY 4060365	36.5"

Dodge Alternator Belt

Alt. Pulley Size	Belt Size	Part Number
2.5"	25.0"	GDY 4030250
3.5"	26.5"	GDY 4030265