



INSTALLATION INSTRUCTIONS

77-9036KP TOYOTA 2012-16 Tundra V8-5.7L

NOTE: This kit was not designed to fit vehicles with a body lift.

TOOLS NEEDED:

Flat Blade Screwdriver
Phillips Screwdriver
Ratchet
Extension
10mm Socket
9/16 Wrench
10mm Wrench
3mm Allen Wrench
4mm Allen Wrench

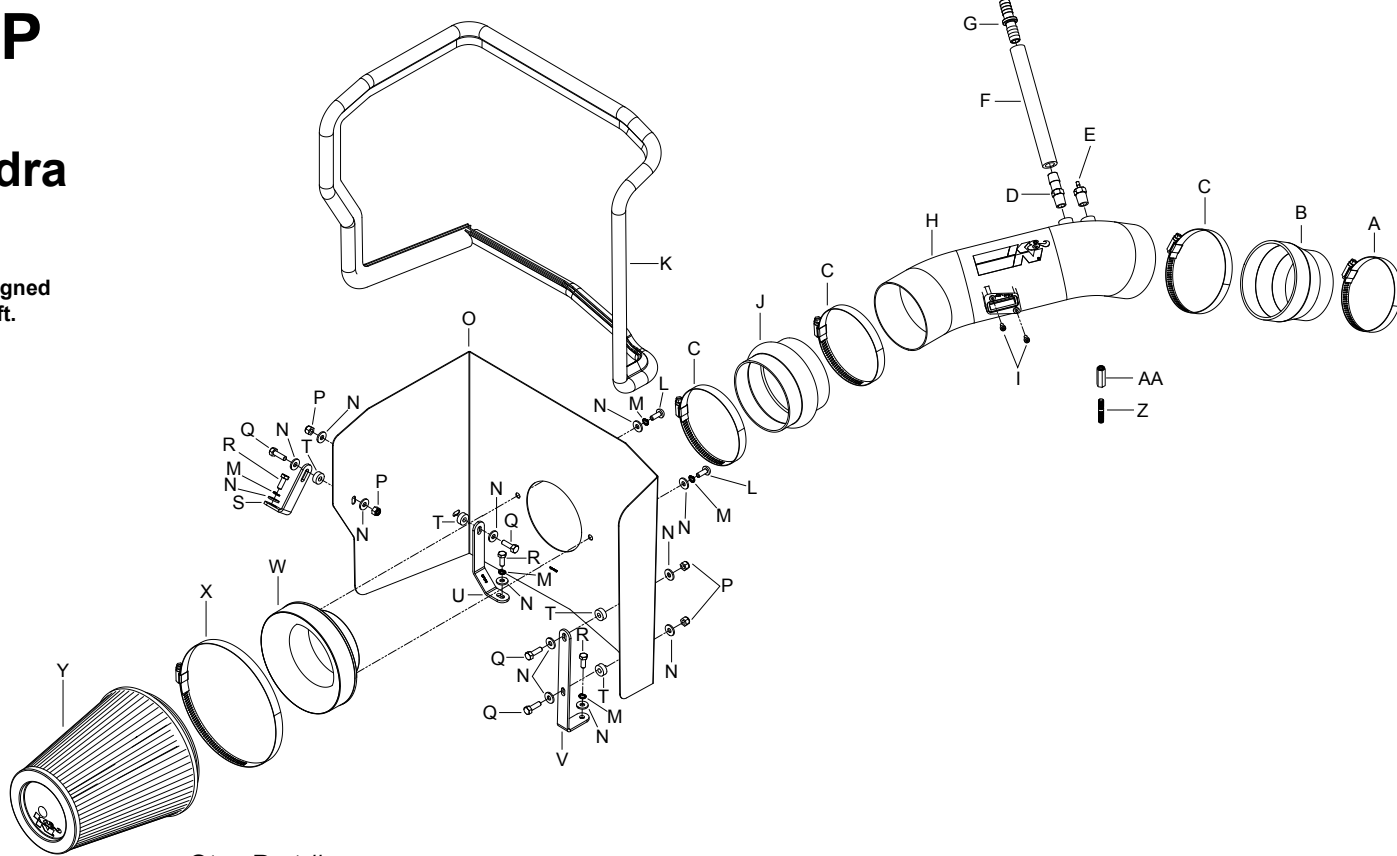

PARTS LIST:

Description	Qty.	Part #	Description	Qty.	Part #	Description	Qty.	Part #
A Hose Clamp # 56	1	08620	J Hose; 4" ID X 3" L Hump Reinforced	1	08418	S Bracket; 57-3017, "L," Fin, TB/PC	1	070742
B Hose; 4" ID To 3.5" ID X 3" L TPRD	1	08497	K Edge Trim (75")	1	102460	T Spacer; .625" OD X .250" ID X .250" L	4	06555
C Hose Clamp # 64 Stainless	3	08645	L Bolt; M6 X 1.00 X 16MM, ButnHd. SS	2	07730	U Bracket; 63-1088, Mild STL, TB/PC	1	07190
D Vent; STRT, 1/8 Hose, 1/4 NPT, Plastic	1	08052	M Washer; M6 Split Lock Zinc	5	1-3025	V Bracket; 57-1513, L-Bend, Fin, TB/PC	1	070902
E Vent; STRT 1/2" Hose, 1/4"NPT, Plas	1	080022	N Washer; 1/4" ID X 5/8" OD -SAE	13	08275	W Adaptor; 57-3058 #454	1	27300
F Hose; 1/2" ID X 7"L	1	08159	O Heat Shield	1	074107	X Hose Clamp # 104	1	08697
G Hose Mender; 1/2" Barbed, Nylon	1	08686	P Nut; 6MM Nylock, Hexhead, SS	4	07512	Y Air Filter	1	RF-1044
H Intake Tube	1	27549KP	Q Bolt; M6 X 1.00" X 20MM Hex, SS	4	07795	Z Stud	1	1-107
I Bolt; M4-0.07 8MM, A/H Cap, SS	2	07733	R Bolt; 6MM-1.00 X 16MM, SS	3	07812	AA Nut Extension	1	08254

NOTE: FAILURE TO FOLLOW INSTALLATION INSTRUCTIONS AND NOT USING THE PROVIDED HARDWARE MAY DAMAGE THE INTAKE TUBE, THROTTLE BODY AND ENGINE.

TO START:

1. Turn off the ignition and disconnect the negative battery cable.

NOTE: Disconnecting the negative battery cable erases pre-programmed electronic memories. Write down all memory settings before disconnecting the negative battery cable. Some radios will require an anti-theft code to be entered after the battery is reconnected. The anti-theft code is typically supplied with your owner's manual. In the event your vehicles' anti-theft code cannot be recovered, contact an authorized dealership to obtain your vehicles anti-theft code.



2. Disconnect the mass air sensor electrical connection and then unhook the wiring harness from the air box.



3. Lift off the engine cover.



4. Loosen the hose clamp that secures the intake tube to the throttle body.



5. Disconnect the crank case vent hose and fuel pressure line from the intake resonator.



6. Release the four retaining clips securing the upper air box, then remove the upper air box and intake tube assembly from the vehicle.



7. Loosen the two bolts securing the lower air box, and then remove the lower air box from the vehicle. **NOTE: K&N Engineering, Inc., recommends that customers do not discard factory air intake.**



8. Remove the bolt securing the ground strap to the inner fender.



9. Install the heat shield mounting bracket (070742) onto the heat shield using the provided spacer and hardware.

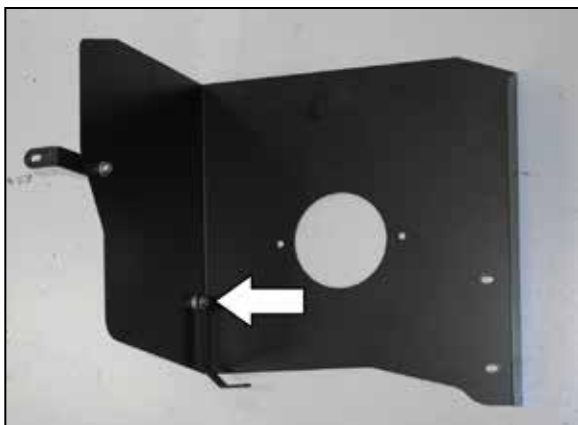

10. Install the heat shield mounting bracket (07190) onto the heat shield using the provided spacer and hardware.

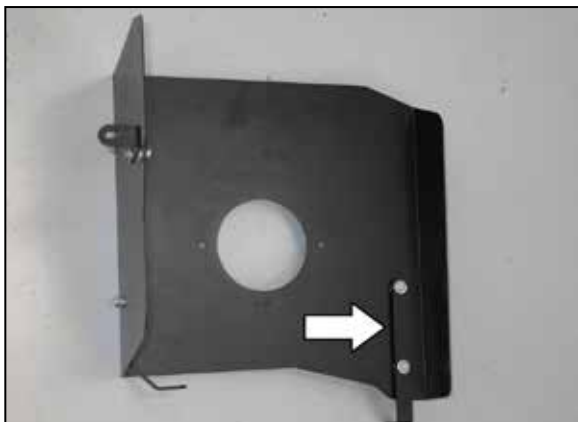

11. Install the heat shield mounting bracket (070902) onto the heat shield using the provided spacers and hardware.



12. Install the filter adapter onto the heat shield and secure with the provided hardware.



13. Install the provided edge trim onto the heat shield as shown.
NOTE: Some trimming of the edge trim will be necessary.



14. Set the heat shield into the engine compartment and secure the factory install nuts with the provided hardware.
NOTE: Be sure to place the ground strap between the mounting bracket and the inner fender, then secure with the heat shield mounting bolt.



15. Install the silicone hose (08497) onto the throttle body and secure with the provided hose clamp.



16. Install the silicone hump hose (08418) onto the filter adapter and secure with the provided hose clamp.



17. Remove the two screws securing the mass air sensor. Remove the mass air sensor from the upper air box housing.



18. Install the mass air sensor into the intake tube and secure with the provided hardware.



19. Install the provided NPT vent fittings into the K&N® intake tube as shown.
NOTE: Plastic NPT fittings are easy to cross thread. Install the vent fitting "hand" tight, then turn it two complete turns with a wrench.



20. Install the hose mender into the provided crank case vent hose as shown.



21. Install the crank case vent hose assembly into the factory crank case vent hose as shown.



22. Install the K&N® intake tube into the hump hose attached to the heat shield and then into the step hose attached to the throttle body. Secure with the provided hose clamps.



23. Connect the crank case vent hose and the fuel pressure hose to the fittings connected to the K&N® intake tube.



24. Install the K&N® air filter and secure with the provided hose clamp.
NOTE: Drycharger® air filter wrap; part # RF-1020DK is available to purchase separately.



25. Reconnect the mass air sensor electrical connection.



26. Remove the front engine cover mounting stud from the intake manifold.



27. Install the provided stud into the mounting stud location as shown.



28. Install the provided nut extension onto the stud as shown.



29. Install the mounting stud into the nut extension as shown.



30. Install the engine cover.



31. Reconnect the vehicle's negative battery cable. Double check to make sure everything is tight and properly positioned before starting the vehicle.

32. It will be necessary for all K&N® high flow intake systems to be checked periodically for realignment, clearance and tightening of all connections. Failure to follow the above instructions or proper maintenance may void warranty.

ROAD TESTING:

1. Start the engine with the transmission in neutral or park, and the parking brake engaged. Listen for air leaks or odd noises. For air leaks secure hoses and connections. For odd noises, find cause and repair before proceeding. This kit will function identically to the factory system except for being louder and much more responsive.

2. Test drive the vehicle. Listen for odd noises or rattles and fix as necessary.

3. If road test is fine, you can now enjoy the added power and performance from your kit.

4. K&N Engineering, Inc., requires cleaning the intake system's air filter element every 100,000 miles. When used in dusty or off-road environments, our filters will require cleaning more often. We recommend that you visually inspect your filter once every 25,000 miles to determine if the screen is still visible. When the screen is no longer visible some place on the filter element, it is time to clean it. To clean and re-oil, purchase our filter Recharger® service kit, part number 99-5050 or 99-5000 and follow the easy instructions.