



## INSTALLATION INSTRUCTIONS

### 77-9025KP TOYOTA 2005-11 Tacoma V6-4.0L

**NOTE:** This kit was not designed to fit vehicles with a body lift.

#### TOOLS NEEDED:

Ratchet  
Extension  
4mm Socket  
10mm Socket  
12mm Socket  
13mm Socket  
Phillips Screwdriver  
2.5mm Allen  
10mm Wrench

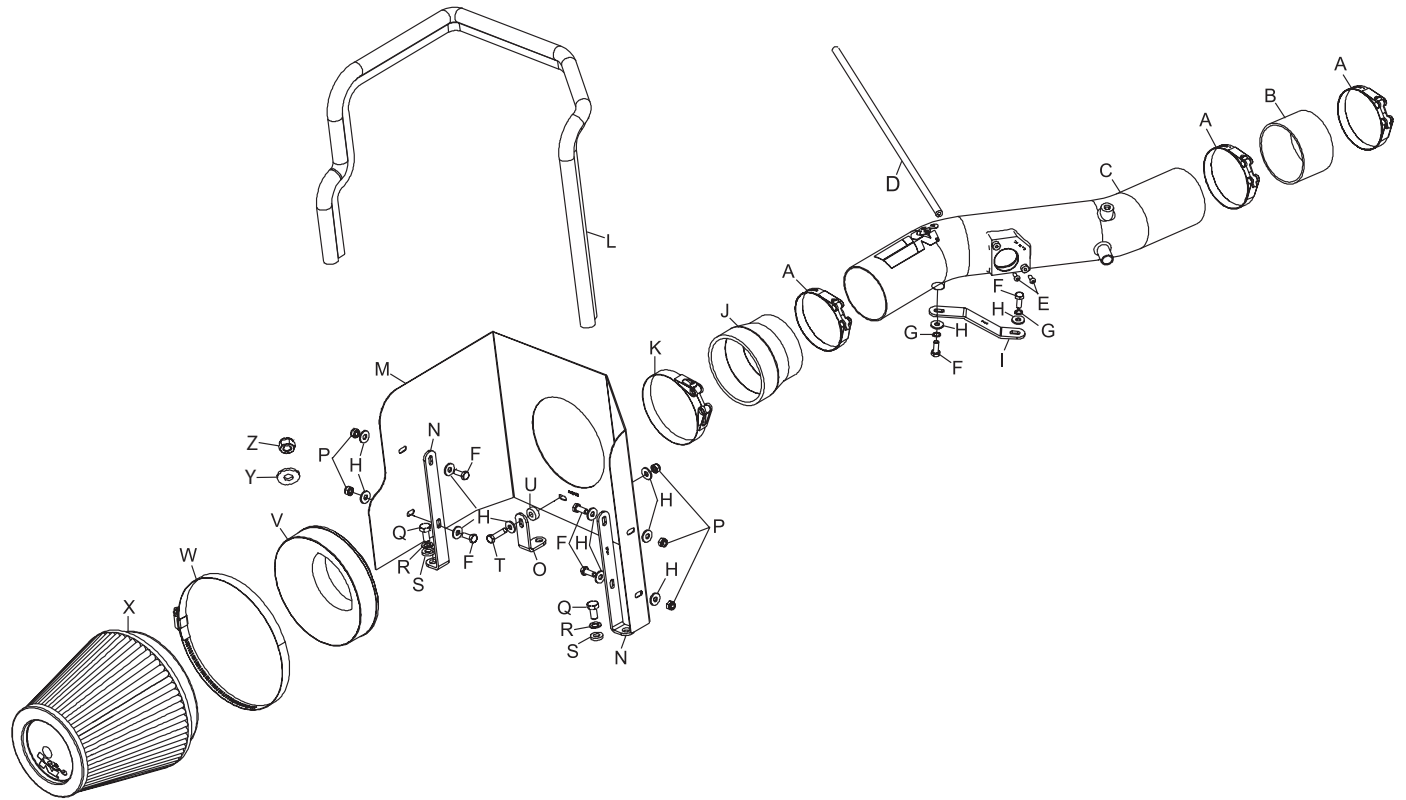

#### PARTS LIST:

Description	Qty.	Part #	Description	Qty.	Part #	Description	Qty.	Part #
A Hose Clamp #48	3	08601	J Hose; 3.0"ID to 3.5"LDx3.0"L, TPRD	1	084055	S Washer; 5/16"ID x 5/8"OD, Flat	2	08276
B Hose; 3.0"ID x 2.0"L, Blk.	1	08434	K Hose Clamp #56	1	08620	T Bolt; 6mm-1.00x25mm, Hex Head	1	07704
C Intake Tube	1	27415KP	L Edge Trim 44"	1	102486	U Spacer; .625"OD x .250"ID x .250"L	1	06555
D Hose; 4mm x 18"L, Blk. Silicone	1	08153	M Heat Shield	1	074039	V Filter Adapter #380	1	21512-1
E Bolt; M4-.7x12mm, Bttn. Head Allen	2	07726	N Bracket; Large "L"	2	07159	W Hose Clamp #104	1	08697
F Bolt; 6mm-1.00 x 16mm, Hex Head	6	07703	O Bracket; Small "L"	1	070812	X Air Filter	1	RF-1048
G Washer; 1/4"ID Split Lock	2	08198	P Nut; 6mm Nylock	5	07553	Y Washer; 8mm, Flat, SS	1	08272
H Washer; 1/4"ID x 5/8" Flat	12	08275	Q Bolt; 8mm-1.25 x 16mm Hex Head	2	07844	Z Nut; 8mm Nylock, SS	1	07502
I Bracket "Z"	1	010099	R Washer; 8mm Wave	2	08239			

**NOTE: FAILURE TO FOLLOW INSTALLATION INSTRUCTIONS AND NOT USING THE PROVIDED HARDWARE MAY DAMAGE THE INTAKE TUBE, THROTTLE BODY AND ENGINE.**

#### TO START:

1. Turn off the ignition and disconnect the negative battery cable.

**NOTE:** Disconnecting the negative battery cable erases pre-programmed electronic memories. Write down all memory settings before disconnecting the negative battery cable. Some radios will require an anti-theft code to be entered after the battery is reconnected. The anti-theft code is typically supplied with your owner's manual. In the event your vehicles' anti-theft code cannot be recovered, contact an authorized dealership to obtain your vehicles anti-theft code.

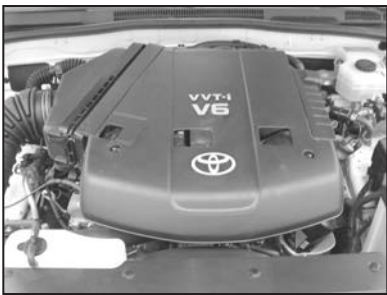

2. Loosen the two nuts that secure the engine cover, then remove the engine cover.



3. Loosen the hose clamps at the air box and resonator.

**NOTE:** On 2008 and later model vehicles, please skip to step #6.



4. Pull the wire harness clip up to release it from the intake tube.



5. Remove the intake tube from the vehicle as shown.



6. Remove the two bolts that secure the resonator to the inner fender, then remove the resonator from the vehicle as shown.

**NOTE:** On 2008 and later model vehicles, the intake tube will be attached to the resonator chamber.



7. Disconnect the two mass air wire harness retaining clips from the air box, then disconnect the mass air sensor electrical connection.

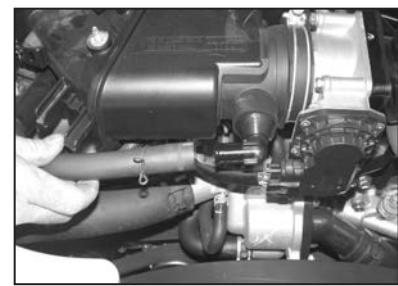

8. Remove the crank case vent hose from the air box as shown.



9. Remove the fuel pressure regulator hose from the back side of the air box.



10. Loosen the hose clamp at the throttle body, then remove the two bolts that secure the air box to the engine.



11. Remove the air box assembly from the engine as shown.

**NOTE: K&N Engineering, Inc., recommends that customers do not discard factory air intake.**

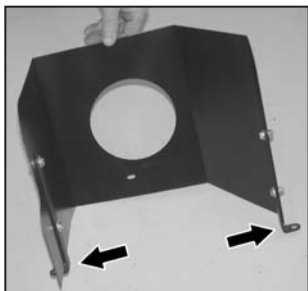

12. Install the two heat shield brackets (07159) onto the heat shield as shown with the provided hardware.



13. Install the small heat shield mounting bracket (070812) with the provided spacer onto the heat shield as shown.

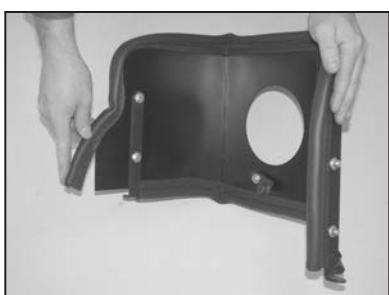

14. Install the provided edge trim onto the heat shield as shown.

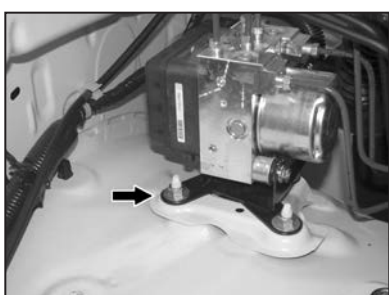

15. Remove the ABS pump mounting nut shown. **NOTE: This nut will be reused. Some vehicles may not be equipped with the ABS pump.**

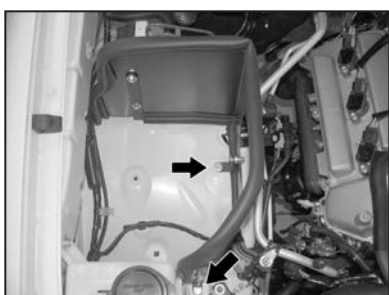

16. Install the heat shield onto the vehicle and secure with the provided hardware and the nut removed in step #15.

**NOTE: On vehicles not equipped with ABS, secure the heat shield to the factory stud using the provided nut and washer.**



17. Install the silicone hose (08434) onto the throttle body with the provided hose clamps as shown.



18. Remove the two screws that secure the mass air sensor to the air box assembly, then remove the mass air sensor as shown.



19. Install the mass air sensor into the K&N® intake tube as shown using the provided hardware.

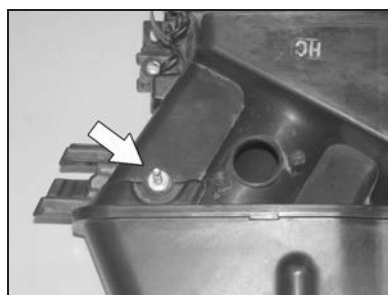

20. Using a 4mm socket, remove the engine cover mounting stud from the stock air box.

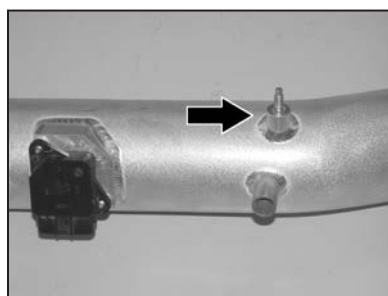

21. Install the engine cover-mounting stud into the K&N® intake tube as shown.

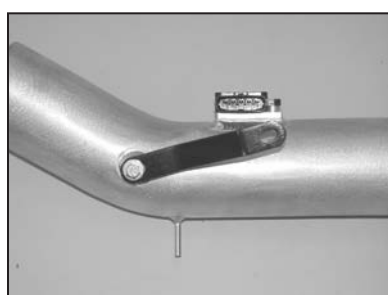

22. Install the provided tube-mounting bracket onto the K&N® intake tube with the provided hardware as shown.

**NOTE: Do not completely tighten at this time.**



23. Install the K&N® intake tube assembly onto the throttle body and align the tube-mounting bracket with the threaded boss on the valve cover; secure with the provided hardware as shown.



24. Remove the stock vacuum hose from the fuel pressure regulator. Install the provided silicone hose onto the fuel pressure regulator and then attach the opposite end to the K&N® intake tube.



25. Install the original crank case vent hose onto the valve cover, then connect the crank case vent hose onto the K&N® intake tube.



26. Install the radius filter adapter into the air filter and secure with the provided hardware as shown.



27. Install the provided silicone hose (084055) onto the air filter assembly and secure with the provided hose clamp as shown.



28. Install the K&N® air filter onto the intake tube as shown.



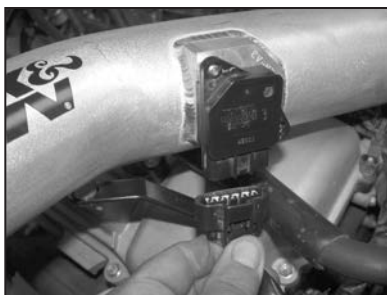

29. Reconnect the mass air sensor electrical connection.

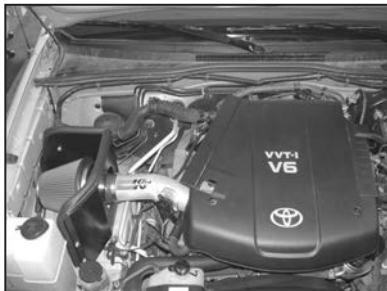

30. Reconnect the vehicle's negative battery cable. Double check to make sure everything is tight and properly positioned before starting the vehicle.

31. It will be necessary for all K&N® high flow intake systems to be checked periodically for realignment, clearance and tightening of all connections. Failure to follow the above instructions or proper maintenance may void warranty.

#### ROAD TESTING:

1. Start the engine with the transmission in neutral or park, and the parking brake engaged. Listen for air leaks or odd noises. For air leaks secure hoses and connections. For odd noises, find cause and repair before proceeding. This kit will function identically to the factory system except for being louder and much more responsive.

2. Test drive the vehicle. Listen for odd noises or rattles and fix as necessary.

3. If road test is fine, you can now enjoy the added power and performance from your kit.

4. K&N Engineering, Inc., requires cleaning the intake system's air filter element every 100,000 miles. When used in dusty or off-road environments, our filters will require cleaning more often. We recommend that you visually inspect your filter once every 25,000 miles to determine if the screen is still visible. When the screen is no longer visible some place on the filter element, it is time to clean it. To clean and re-oil, purchase our filter Recharger® service kit, part number 99-5050 or 99-5000 and follow the easy instructions.