

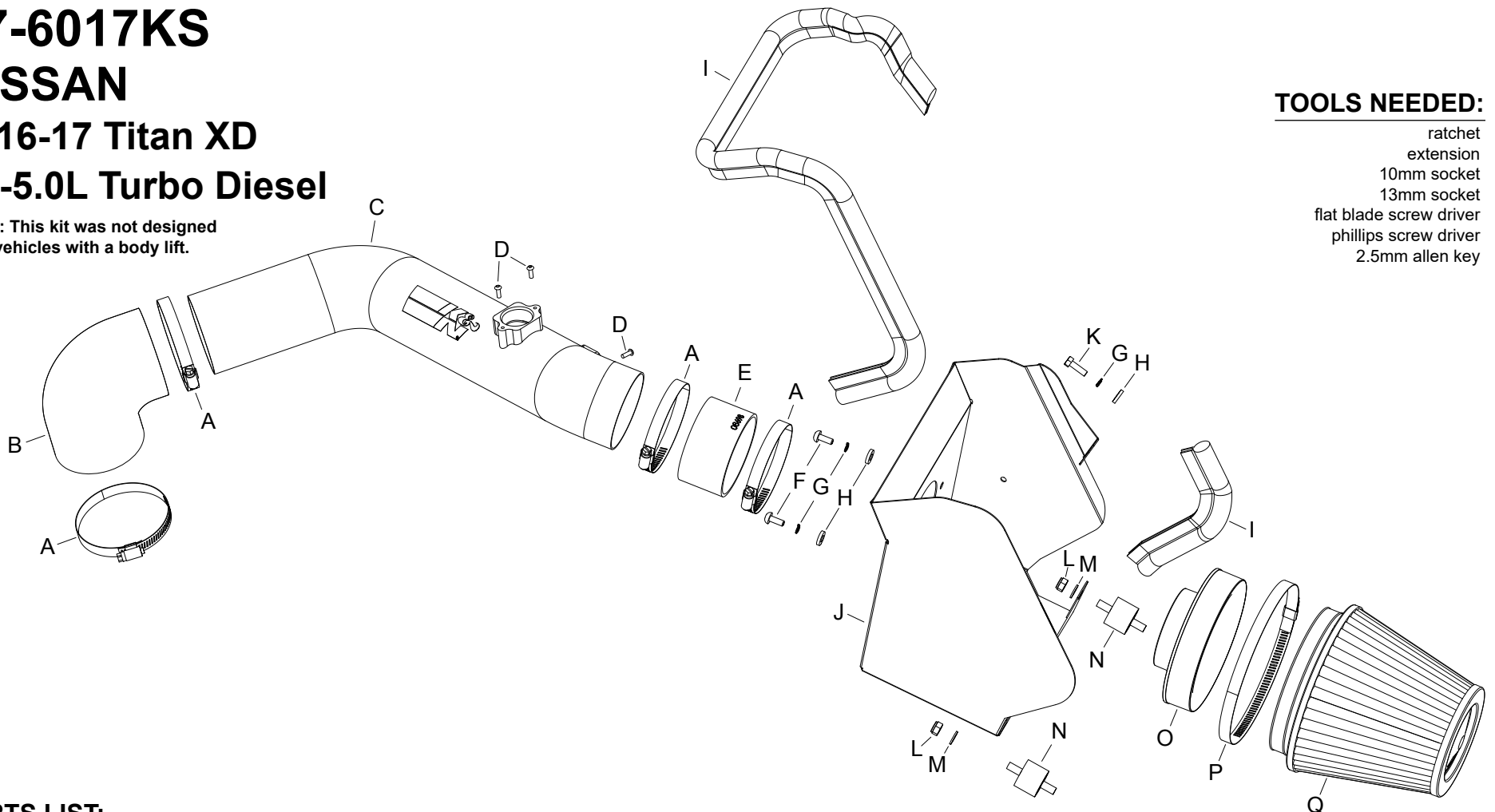

INSTALLATION INSTRUCTIONS

77-6017KS NISSAN 2016-17 Titan XD V8-5.0L Turbo Diesel

NOTE: This kit was not designed to fit vehicles with a body lift.



TOOLS NEEDED:

ratchet
extension
10mm socket
13mm socket
flat blade screw driver
phillips screw driver
2.5mm allen key

PARTS LIST:

Description	Qty.	Part #	Description	Qty.	Part #	Description	Qty.	Part #
A HOSE CLAMP #56	4	08620	G WASHER, M6 SPLIT LOCK ZINC	3	1-3025	M WASHER; 8MM, FLAT, SS	2	08272
B HOSE; 3-1/2"ID 90DEG ANGLED	1	08502	H WASHER; 1/4"ID X 5/8"OD	3	08275	N STUD; RUBBER MOUNTED, 1"L	2	070227
C INTAKE TUBE	1	27670S	I EDGE TRIM (55")	1	102480	O ADAPTER; UNIVERSAL, 6"	1	21512-1
D SCREW; M4- .7 X 12, BUTTON	3	07726	J HEAT SHIELD	1	073233	P HOSE CLAMP # 104	1	08697
E HOSE; 3-1/2" ID X 2" L	1	08698	K BOLT; M6 X 1.00" X 20MM HEX	1	07795	Q AIR FILTER	1	RF-1042XD
F BOLT; M6 X 1.00 X 16MM, SS	2	07730	L NUT; 8MM NYLOCK, SS	2	07502			

NOTE: FAILURE TO FOLLOW INSTALLATION INSTRUCTIONS AND NOT USING THE PROVIDED HARDWARE MAY DAMAGE THE INTAKE TUBE, THROTTLE BODY AND ENGINE.

TO START:

1. Turn off the ignition and disconnect the negative battery cable.

NOTE: Disconnecting the negative battery cable erases pre-programmed electronic memories. Write down all memory settings before disconnecting the negative battery cable. Some radios will require an anti-theft code to be entered after the battery is reconnected. The anti-theft code is typically supplied with your owner's manual. In the event your vehicles anti-theft code cannot be recovered, contact an authorized dealership to obtain your vehicles anti-theft code.



2. Disconnect the mass air sensor and inlet air temperature sensor electrical connections.



3. Loosen the hose clamp that secure the intake tube to the turbo inlet and then release the two clam shell clips that secure the upper air filter housing. Remove the upper air filter housing and intake tube from the vehicle.

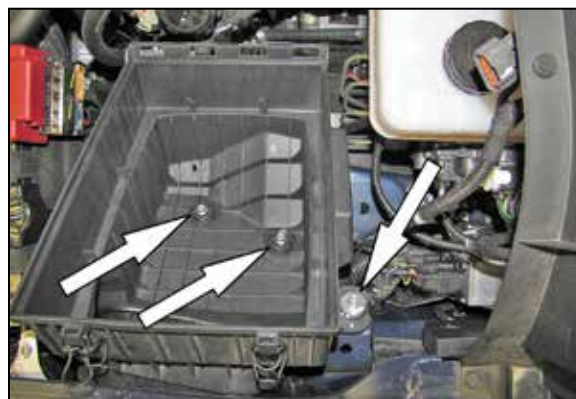

4. Loosen the three bolts that secure the lower air filter housing and then remove the housing from the vehicle.

NOTE: the two bolts inside the housing are captured and cannot be removed from the grommets.
NOTE: K&N Engineering, Inc., recommends that customers do not discard factory air intake.



5. Install the two provided rubber mounted studs into the air filter housing mounting locations as shown.

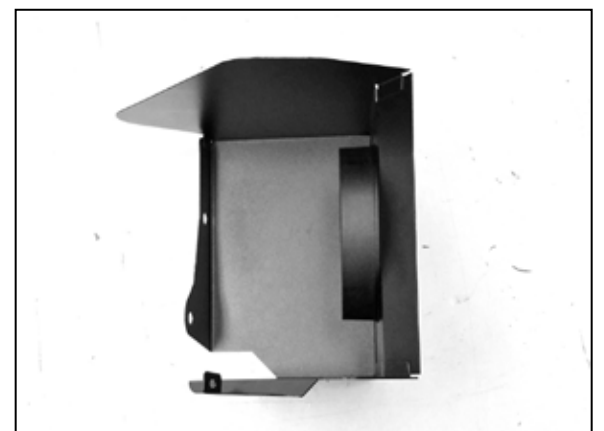

6. Install the provided filter adapter into the heat shield and secure with the provided hardware.

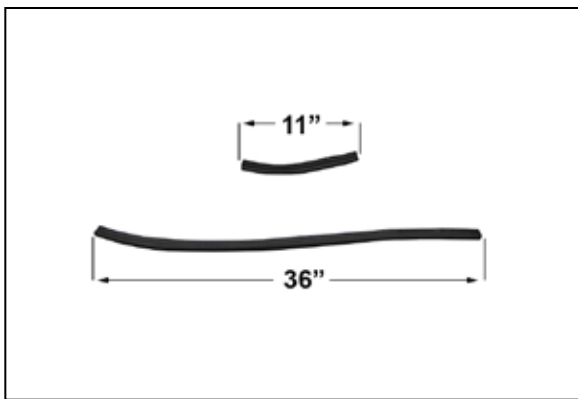

7. Cut the provided edge trim into two sections, one section will be 11" long and the section will be 36" long.



8. Install the edge trim onto the heat shield as shown.



9. Set the heat shield onto the rubber mounted studs installed previously and secure with the provided nuts and washers.

NOTE: Do not install the bolt at this time.



10. Install the air filter onto the filter adapter and secure with the provided hose clamp. Secure the heat shield to the remaining mount with the hardware provided.

NOTE: Drycharger® air filter wrap; part # RF-1042XD is available to purchase separately.



11. Install the provided coupler hose (08502) onto the turbo inlet and secure with the provided hose clamp.



12. Install the provided coupler hose (08698) onto the filter adapter and secure with the provided hose clamp.



13. Remove the two sensors from the stock air filter housing.



14. Install the sensors into the K&N® intake tube and secure with the provided hardware.



15. Install the K&N® intake tube into the coupler at the filter adapter and then into the hose at the turbo inlet, adjust the tube for best fit and then secure with the provided hose clamps.



15. Reconnect the mass air sensor and inlet air temperature sensor electrical connections.



16. Reconnect the vehicle's negative battery cable. Double check to make sure everything is tight and properly positioned before starting the vehicle.

17. It will be necessary for all K&N® high flow intake systems to be checked periodically for realignment, clearance and tightening of all connections. Failure to follow the above instructions or proper maintenance may void warranty.

ROAD TESTING:

1. Start the engine with the transmission in neutral or park, and the parking brake engaged. Listen for air leaks or odd noises. For air leaks secure hoses and connections. For odd noises, find cause and repair before proceeding. This kit will function identically to the factory system except for being louder and much more responsive.

2. Test drive the vehicle. Listen for odd noises or rattles and fix as necessary.

3. If road test is fine, you can now enjoy the added power and performance from your kit.

4. K&N Engineering, Inc., requires cleaning the intake system's air filter element every 100,000 miles. When used in dusty or off-road environments, our filters will require cleaning more often. We recommend that you visually inspect your filter once every 25,000 miles to determine if the screen is still visible. When the screen is no longer visible some place on the filter element, it is time to clean it. To clean and re-oil, purchase our filter Recharger® service kit, part number 99-5050 or 99-5000 and follow the easy instructions.